

ORIGINAL INSTRUCTIONS

HYUNDAI

POWER EQUIPMENT

Instruction Manual

CORDLESS JIG SAW

HSS20V



CAUTION: READ THIS INSTRUCTION MANUAL BEFORE USE THIS MACHINE

32, rue Aristide Bergès - ZI 31270 Cugnaux – France
MADE IN PRC 2018
Licensed by Hyundai Corporation, Korea



1. SAFETY INSTRUCTIONS



WARNING Read all safety warnings and all instructions. *Failure to follow the warnings and instructions may result in electric shock, fire and/or serious injury.*

Save all warnings and instructions for future reference. *The term "power tool" in the warnings refers to your mains-operated (corded) power tool or battery-operated (cordless) power tool.*

1) Work area safety

- a) **Keep work area clean and well lit.** *Cluttered or dark areas invite accidents.*
- b) **Do not operate power tools in explosive atmospheres, such as in the presence of flammable liquids, gases or dust.** *Power tools create sparks which may ignite the dust or fumes.*
- c) **Keep children and bystanders away while operating a power tool.** *Distractions can cause you to lose control.*

2) Electrical safety

- a) **Power tool plugs must match the outlet. Never modify the plug in any way. Do not use any adapter plugs with earthed (grounded) power tools.** *Unmodified plugs and matching outlets will reduce risk of electric shock.*
- b) **Avoid body contact with earthed or grounded surfaces, such as pipes, radiators, ranges and refrigerators.** *There is an increased risk of electric shock if your body is earthed or grounded.*
- c) **Do not expose power tools to rain or wet conditions.** *Water entering a power tool will increase the risk of electric shock.*
- d) **Do not abuse the cord. Never use the cord for carrying, pulling or unplugging the power tool. Keep cord away from heat, oil, sharp edges or moving parts.** *Damaged or entangled cords increase the risk of electric shock.*
- e) **When operating a power tool outdoors, use an extension cord suitable for outdoor use.** *Use of a cord suitable for outdoor use reduces the risk of electric shock.*
- f) **If operating a power tool in a damp location is unavoidable, use a residual current device (RCD) protected supply.** *Use of an RCD reduces the risk of electric shock.*

3) Personal safety

- a) **Stay alert, watch what you are doing and use common sense when operating a power tool. Do not use a power tool while you are tired or under the influence of drugs, alcohol or medication.** *A moment of inattention while operating power tools may result in serious personal injury.*
- b) **Use personal protective equipment. Always wear eye protection.** *Protective equipment such as dust mask, non-skid safety shoes, hard hat, or hearing protection used for appropriate conditions will reduce personal injuries.*
- c) **Prevent unintentional starting. Ensure the switch is in the off-position connecting to power source and/or battery pack, picking up or carrying the tool.** *Carrying power tools with your finger on the switch or energizing power tools that have the switch on invites accidents.*
- d) **Remove any adjusting key or wrench before turning the power tool on.** *A wrench or a*

key left attached to a rotating part of the power tool may result in personal injury.

e) **Do not overreach. Keep proper footing and balance at all times.** *This enables better control of the power tool in unexpected situations.*

f) **Dress properly. Do not wear loose clothing or jewelry. Keep your hair, clothing and gloves away from moving parts.** *Loose clothes, jewelry or long hair can be caught in moving parts.*

g) **If devices are provided for the connection of dust extraction and collection facilities, ensure these are connected and properly used.** *Use of dust collection can reduce dust-related hazards.*

4) Power tool use and care

a) **Do not force the power tool. Use the correct power tool for your application.** *The correct power tool will do the job better and safer at the rate for which it was designed.*

b) **Do not use the power tool if the switch does not turn it on and off.** *Any power tool that cannot be controlled with the switch is dangerous and must be repaired.*

c) **Disconnect the plug from the power source and/or the battery pack from the power tool before making any adjustments, changing accessories, or storing power tools.** *Such preventive safety measures reduce the risk of starting the power tool accidentally.*

d) **Store idle power tools out of the reach of children and do not allow persons unfamiliar with the power tool or these instructions to operate the power tool.** *Power tools are dangerous in the hands of untrained users.*

e) **Maintain power tools. Check for misalignment or binding of moving parts, breakage of parts and any other condition that may affect the power tool's operation. If damaged, have the power tool repaired before use.** *Many accidents are caused by poorly maintained power tools.*

f) **Keep cutting tools sharp and clean.** *Properly maintained cutting tools with sharp cutting edges are less likely to bind and are easier to control.*

g) **Use the power tool, accessories and tool bits etc. in accordance with these instructions, taking into account the working conditions and the work to be performed.** *Use of the power tool for operations different from those intended could result in a hazardous situation.*

5) Battery tool use and care

a) **Recharge only with the charger specified by the manufacturer.** *A charger that is suitable for one type of battery pack may create a risk of fire when used with another battery pack.*

b) **Use power tools only with specifically designated battery packs.** *Use of any other battery packs may create a risk of injury and fire.*

c) **When battery pack is not in use, keep it away from other metal objects, like paper clips, coins, keys, nails, screws or other small metal objects, that can make a connection from one terminal to another.** *Shorting the battery terminals together may cause burns or a fire.*







d) **Under abusive conditions, liquid may be ejected from the battery; avoid contact. If contact accidentally occurs, flush with water. If liquid contacts eyes, additionally seek medical help.** *Liquid ejected from the battery may cause irritation or burns.*

6) Service

a) **Have your power tool serviced by a qualified repair person using only identical replacement parts.** *This will ensure that the safety of the power tool is maintained.*

Hold power tool by insulated gripping surfaces, when performing an operation where the cutting accessory may contact hidden wiring. *Cutting accessory contacting a "live" wire may make exposed metal parts of the power tool "live" and could give the operator an electric shock.*

Explanations of symbols

	Conforms to relevant safety standards
	To reduce the risk of injury, the user must read and understand this manual before using this
	Wear ear protectors. Exposure to noise can
	Wear eye protection.
	Wear respiratory protection.
	Do not dispose of old appliances with domestic

Intended Use

This machine is a cutting tool cutting materials such as wood or steel or metal using a blade. Do not use this tool for other activities. Use this tool as described in this manual, cutting only the appropriate materials with the appropriate blades. Misuse can result in accidents and personal injury.

Residual risks

These residual risks can occur at any time during the operation of the tool:

- Contact and cuts from the blade
- Inhalation of particles from material to be cut
- Projection of the cutting element
- Projection of cut material
- Development of toxic dusts / fumes when used in confined spaces (vomiting / nausea)
- Hearing loss in the absence of good hearing protection

To reduce these residual risks, always wear a full protective gear and always be careful when using the tool.

2. YOUR PRODUCT

a. Description

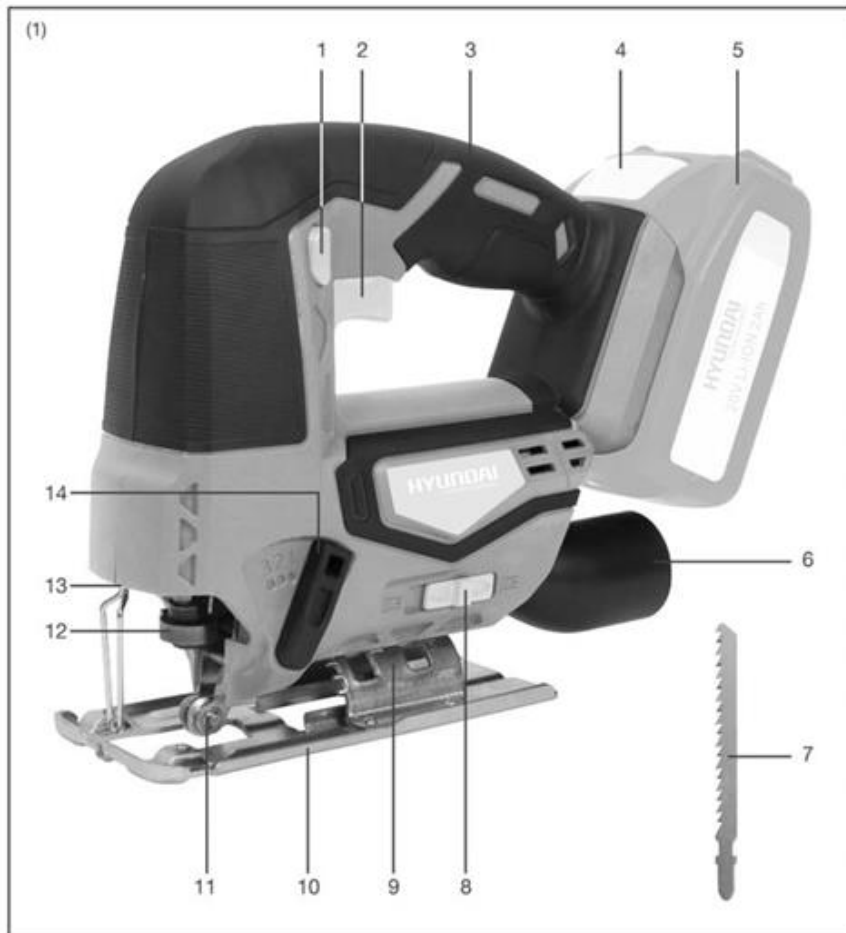

1. Lock-off button
2. ON/OFF trigger
3. Handle
4. Battery release catch
5. Li-on battery
6. Dust extraction outlet
7. Wood cutting saw blade
8. Forward/rear air outlet ON/OFF
9. Angle scale
10. Saw base
11. Blade roller support
12. Quick change blade clamp lever
13. Work light

14. Orbital adjustment knob

A hexagon key is delivered with the tool

b. Technical specifications

voltage	20 V d.c.
No load speed	0-2500/min
Blade type	T type blade
Max cut in wood (mm)	50
Max cut in steel (mm)	5
Cutting angle	0°/15°/30°/45°
Sound pressure level	LpA=76dB(A), K=3dB(A)
Sound power level	LwA=87dB(A), K=3dB(A)
Vibration	<u>Cutting board</u> 6.28m/s ² , K=1.5 m/s ² <u>Cutting steel metal</u> 5.78m/s ² , K=1.5 m/s ²

Information:

- The declared vibration total value has been measured in accordance with a standard test method and may be used for comparing one tool with another;
- The declared vibration total value may also be used in a preliminary assessment of exposure.

Warning:

- that the vibration emission during actual use of the power tool can differ from the declared total value depending on the ways in which the tool is used; and
- of the need to identify safety measures to protect the operator that are based on an estimation of exposure in the actual conditions of use (taking account of all parts of the operating cycle such as the times when the tool is switched off and when it is running idle in addition to the trigger time).

Wear hearing protection.

2. UTILISATION

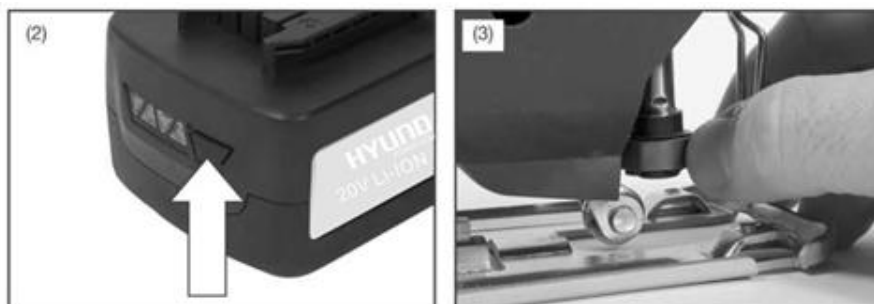

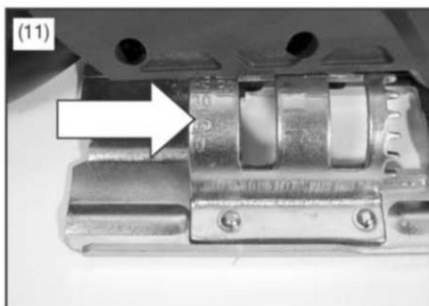
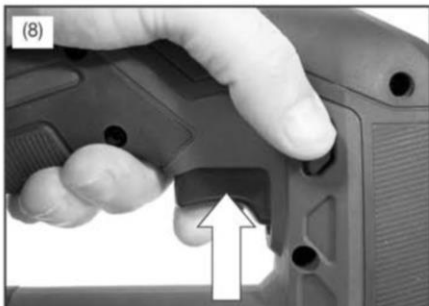
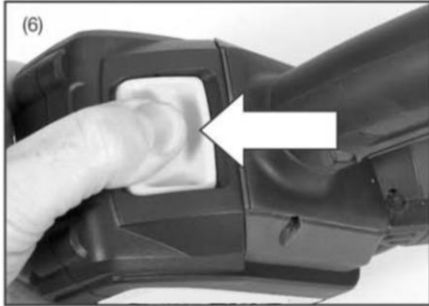

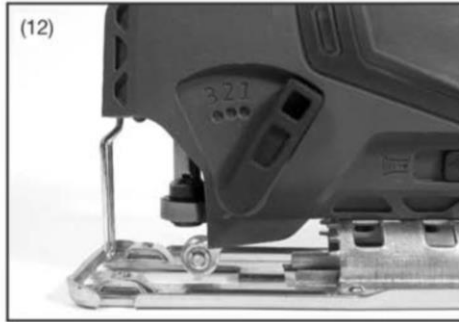

a. Charging

HYUNDAI range battery and charger not sold together. Battery has not been fully charged at the factory.

Before using it for the first time, charge the screwdriver's battery for 60min to 130min. Insert the charger plug into the charging socket and plug the charger into a 230V/50Hz electrical outlet. Detailed information please read carefully the manual for battery and charger.

b. Charge status

To display the amount of charge left in the battery, press the charge level indicator button, Fig.2.

Charge level indicator	Amount of charge remaining
	0-10%
	10-25%
	25-50%
	50-75%
	75-100%

c. INSTALLING JIGSAW BLADES

Selecting the correct type of blade is important in order to obtain the best performance from the saw. Select the blade based on the application and on the material you wish to cut. Selecting the right blade will give you a smoother, faster cut and prolong the life of the blade.

Note: Before attaching a blade please ensure that the battery is not connected to the jigsaw.

To fit the blade, push the quick change blade clamp lever until it stops, Fig 3.

Holding the blade clamp lever in the open position, insert the saw blade as far as possible into the slot in the saw bar, Fig 4.

Check to make sure the back of the saw blade is centered in the groove of the roller guide. Release the blade clamp lever. Make sure the blade is securely in place.

Note: During use periodically check the security of the blade.

d. INSTALLING THE BATTERY PACK

Warning! Always remove battery pack from your tool when you are assembling parts, making adjustments, cleaning, carrying, transporting or when not in use. Removing battery pack will prevent accidental starting that could cause serious personal injury.

NOTE: To avoid serious personal injury, always remove the battery pack and keep hands clear of the lock-out button when carrying or transporting the tool.

Slide the battery pack into the tool base, Fig.5. (Note the battery has raised ribs which allow it to fit into the pole saw only one way). Make sure the battery pack snaps into place and that battery pack is secured in the tool before beginning operation. Improper installation of the battery pack can cause damage to internal components.

e. REMOVING THE BATTERY PACK

Locate the battery release catch on the top of the battery and press downwards, Fig.6. Whilst holding down the battery release catch slide the battery pack away from the tool.

f. TURNING THE JIGSAW ON & OFF

To turn the jigsaw ON, depress the lock-off safety button, Fig 7 and then depress the On/Off switch, Fig 8.

Release the On/Off switch to turn the jigsaw OFF.

g. VARIABLE SPEED CONTROL

Simply apply light pressure to the trigger to start the jigsaw on a slow speed. Increasing the pressure on the trigger will increase the speed of the jigsaw.

Note: You might hear a high pitched noise from the trigger during use. Do not be concerned; this is a normal part of the trigger function.

h. LED WORK LIGHT

Caution: Do not look in the light or see the source of light directly.

Pull the On/Off trigger to light up the lamp. The lamp keeps on lighting while the switch trigger is being pulled. The lamp goes out immediately after releasing the trigger.

i. **ORBITAL MOTION**

The blade of the jigsaw cuts in an orbital motion. This feature is adjustable and provides faster, more efficient cutting.

With orbital motion the blade cuts through your work in the upstroke but does not drag across your work in the down stroke. The higher settings should be used when fast cutting in soft material is desired. The lower settings should be used when cutting materials with more resistance. The '0' setting shuts off the orbital motion. Setting '*3' offers the maximum orbital motion, Fig 9.

j. **ANGLE CUTTING (BEVEL CUTTING)**

Set the cutting angle to one of the preset angles of 0°, 15°, 30*or 45°.

Loosen the two hexagon screws (Fig 10) located on the underside of the machine using the hexagon key provided.

Slightly raise the base until the base can be moved to one of the preset cutting angles shown on the angle scale (Fig 11). Finally re-tighten the hex screws.

k. **GENERAL CUTTING**

Rest the front of the saw base on the workpiece and align cutting edge of the blade with the tine on your workpiece.

Start your saw and move it forward on the work surface. Press the machine firmly down onto the workpiece and push slowly forward letting the blade cut freely. Increasing the pressure will not result in a faster cut.

Note: If the jigsaw base is not held firmly into the workpiece the blade will snag and break.

l. **METAL CUTTING**

NOTE: The jigsaw has to be in the no-orbit mode to cut metals and conduit. Set the orbital adjustment knob to "0", Fig 12.

When cutting metals a suitable cooling/cutting oil must be used. Simply squirt the lubricant onto the blade or work piece at regular intervals during cutting to reduce blade wear.

NOTE: Do not immerse the jigsaw in water or allow coolant to enter the casing. A fatal electric shock could occur.

When cutting conduit, pipe or angle iron, clamp work in a vice if possible and saw close to the vice. To cut thin sheet materials, "sandwich* the material between hardboard or plywood and clamp the layers to eliminate vibration and material tearing. By doing this, the material will be cut smoothly. Lay out your pattern or line of cut on top of the "sandwich."

Note: When cutting metal, keep exposed portion of saw bar clean and free of metal chips by wiping frequently with an oily cloth. Use extreme caution in disposing of oily cloth after completion of job to prevent potential fire hazard.

m. **FORWARD/REAR AIR OUTLET**

The forward air outlet can be used to either blow debris from the blade during operation or send the air to the dust extraction outlet. To select air to be blown towards the blade, slide the switch to the right, Fig 13. To select air to be blown towards the dust extraction outlet

slide the switch to the left, Fig 14.

n. **CIRCLE CUTTING**

When starting a cut from the center of the work piece, drill a 12mm diameter hole to ensure that there is enough clearance for the blade.

When cutting materials with a decorative or polished finish cover either the base of the jigsaw or the surface of the material being cut with masking or other suitable tape to prevent scratching.

3. MAINTENANCE

a. **Maintenance**

After each use, remove the accumulator from its compartment and check for damage.

Correct maintenance is essential to maintain the original efficiency and safety of the machine over time.

Keep all nuts, bolts and screws tight to be sure the equipment is in a safe working condition.

Never use the machine with worn or damaged parts. Damaged parts are to be replaced and never repaired.

Only use original spare parts. Parts that are not of the same quality can be seriously damage the equipment and compromise safety.

During maintenance, remove the battery from the tool.

To avoid overheating and damage to the motor, always keep the cooling air vents clean and free of sawdust and debris.

Clean the housing only with a damp cloth. Do not use solvents! Then wipe thoroughly.

Check the condition of the tool. If the tool is damaged or has malfunction, do not use it and bring it to a qualified service for inspection or reparation.

To maintain the optimum battery power, we recommend that the battery be discharged and recharged every two months.

b. **Storage**

Remove the battery from the tool.

Put the blade protection on the blade of the tool during transport and storage.

Store the tool in a dry place and protected from freezing, the ambient temperature should not exceed 50°C. Put it out of the reach of children.

4. DISPOSAL



Electrical products should not be discarded with household products. According to the European Directive 2012/19/EU on waste electrical and electronic equipment and its implementation into national law, electrical products used must be collected separately and disposed of at collection points provided for this purpose. Talk with your local authorities or dealer for advice on recycling.

5. DECLARATION DE CONFORMITY



HYUNDAI

ZI, 32 rue Aristide Bergès – 31270 Cugnaux – France

Declare that the following machine:

Cordless jig saw

HSS20V

Serial number:

**Is in conformity with the Directive Machine 2006/42/EC and with the regulation
transposing it**

Also in conformity with the following Directives:

EMC Directive 2014/30/UE

RoHS Directive 2011/65/UE

Also in conformity with the following standards

EN 60745-1:2009+A11:2010

EN 60745-2-11:2010

EN 55014-1:2006+A1:2009+A2:2011

EN55014-2:1997+A1:2001+A2:2008

Responsible of the technical file: Mr Patriarca

Cugnaux, 01/11/2018

A handwritten signature in black ink, appearing to read 'Philippe MARIE', with a large, sweeping flourish extending from the end of the name.

Philippe MARIE / PDG