



INSTRUCTION MANUAL
Delta sander 130 W
MODEL :RACPDEL130



READ THE INSTRUCTIONS BEFORE USE THIS TOOL.

BUILDER SAS
32 Rue Aristide Berges Zi Du Casque
31270 Cugnaux France
MADE IN PRC

1. SAFETY WARNINGS



General power tool safety warnings

WARNING Read all safety warnings, instructions, illustrations and specifications provided with this power tool. *Failure to follow all instructions listed below may result in electric shock, fire and/or serious injury.*

Save all warnings and instructions for future reference.

The term "power tool" in the warnings refers to your mains-operated (corded) power tool or battery-operated (cordless) power tool.

1) Work area safety

a) **Keep work area clean and well lit.** *Cluttered or dark areas invite accidents.*

b) **Do not operate power tools in explosive atmospheres, such as in the presence of flammable liquids, gases or dust.** *Power tools create sparks which may ignite the dust or fumes.*

c) **Keep children and bystanders away while operating a power tool.** *Distractions can cause you to lose control.*

2) Electrical safety

a) **Power tool plugs must match the outlet. Never modify the plug in any way. Do not use any adapter plugs with earthed (grounded) power tools.** *Unmodified plugs and matching outlets will reduce risk of electric shock.*

b) **Avoid body contact with earthed or grounded surfaces, such as pipes, radiators, ranges and refrigerators.** *There is an increased risk of electric shock if your body is earthed or grounded.*

c) **Do not expose power tools to rain or wet conditions.** *Water entering a power tool will increase the risk of electric shock.*

d) **Do not abuse the cord. Never use the cord for carrying, pulling or unplugging the power tool. Keep cord away from heat, oil, sharp edges or moving parts.** *Damaged or entangled cords increase the risk of electric shock.*

e) **When operating a power tool outdoors, use an extension cord suitable for outdoor use.** *Use of a cord suitable for outdoor use reduces the risk of electric shock.*

f) **If operating a power tool in a damp location is unavoidable, use a residual current device (RCD) protected supply.** *Use of an RCD reduces the risk of electric shock.*

NOTE The term "residual current device (RCD)" can be replaced by the term "ground fault circuit interrupter (GFCI)" or "earth leakage circuit breaker (ELCB)".

3) Personal safety

a) **Stay alert, watch what you are doing and use common sense when operating a power tool. Do not use a power tool while you are tired or under the influence of drugs, alcohol or medication.** *A moment of inattention while operating power tools may result in serious personal injury.*

b) **Use personal protective equipment. Always wear eye protection.** *Protective equipment such as a dust mask, non-skid safety shoes, hard hat or hearing protection used for appropriate conditions will reduce personal injuries.*

c) **Prevent unintentional starting. Ensure the switch is in the off-position before connecting to power source and/or battery pack, picking up or carrying the tool.**

Carrying power tools with your finger on the switch or energising power tools that have the switch on invites accidents.

d) **Remove any adjusting key or wrench before turning the power tool on.** *A wrench or a key left attached to a rotating part of the power tool may result in personal injury.*

e) **Do not overreach. Keep proper footing and balance at all times.** *This enables better control of the power tool in unexpected situations.*

f) **Dress properly. Do not wear loose clothing or jewellery. Keep your hair and clothing away from moving parts.** *Loose clothes, jewellery or long hair can be caught in moving parts.*

g) **If devices are provided for the connection of dust extraction and collection facilities, ensure these are connected and properly used.** *Use of dust collection can reduce dust-related hazards.*

h) Do not let familiarity gained from frequent use of tools allow you to become complacent and ignore tool safety principles. A careless action can cause severe injury within a fraction of a second.

4) Power tool use and care

a) Do not force the power tool. Use the correct power tool for your application. The correct power tool will do the job better and safer at the rate for which it was designed.

b) Do not use the power tool if the switch does not turn it on and off. Any power tool that cannot be controlled with the switch is dangerous and must be repaired.

c) Disconnect the plug from the power source and/or remove the battery pack, if detachable, from the power tool before making any adjustments, changing accessories, or storing power tools. Such preventive safety measures reduce the risk of starting the power tool accidentally.

d) Store idle power tools out of the reach of children and do not allow persons unfamiliar with the power tool or these instructions to operate the power tool.

Power tools are dangerous in the hands of untrained users.

e) Maintain power tools and accessories. Check for misalignment or binding of moving parts, breakage of parts and any other condition that may affect the power tool's operation. If damaged, have the power tool repaired before use. Many accidents are caused by poorly maintained power tools.

f) Keep cutting tools sharp and clean. Properly maintained cutting tools with sharp cutting edges are less likely to bind and are easier to control.

g) Use the power tool, accessories and tool bits etc. in accordance with these instructions, taking into account the working conditions and the work to be performed. Use of the power tool for operations different from those intended could result in a hazardous situation.

h) Keep handles and grasping surfaces dry, clean and free from oil and grease. Slippery handles and grasping surfaces do not allow for safe handling and control of the tool in unexpected situations.

5) Service

a) Have your power tool serviced by a qualified repair person using only identical replacement parts. This will ensure that the safety of the power tool is maintained.

Additional safety warnings for sander

Hold the power tool by insulated gripping surfaces, because the sanding surface may contact its own cord. Cutting a "live" wire may make exposed metal parts of the power tool "live" and could give the operator an electric shock.

If the supply cord is damaged, it must be replaced by a special cord or assembly available from the manufacturer or its service agent.

a) Ensure that the ventilation slots are not blocked.

b) Always clamp the workpiece with a clamping device. Do not hold the workpiece by hand.

c) Use the type of abrasive sheet suitable for the type of work to be performed.

d) Never use oversized sanding tools.

e) Never use damaged or worn abrasive sheets, or sheets that do not stick firmly to the sanding tray.

f) Never place your hand or fingers near the sanding pad when the sander is running.

g) Keep the power cord away from the work area.

h) Keep handle and sander free of oil, grease, water and other liquids.

i) Never touch the sander before it stops.

j) Do not touch the workpiece or metal chips before cooling.

k) Do not use the sander to work on magnesium parts.







Residual risks

Some dusts produced by sanding, sawing, grinding, drilling and other construction operations contain recognized chemical elements capable of causing cancer, birth defects or other reproductive problems. Some examples of these chemicals:

- Lead from base paints
- Crystalline silica from bricks and cement and other masonry products
- Arsenic and chromium from chemically treated wood.

The risk associated with these exposures varies according to the frequency of this type of work. To reduce your exposure to these chemicals: work in a well-ventilated area and use approved safety equipment such as dust masks specifically designed to filter microscopic particles.

Symbols

	Read the instruction manual
	Wear an hearing protection
	Wear protective glasses
	Wear a respiratory protection
	WEEE marking for disposal
	Tool of Class II protection (double isolation)

Intended Use

This power tool is designed for dry sanding of wood, plastic, metal and mastic surfaces as well as varnished surfaces.

2. YOUR TOOL

a. Description

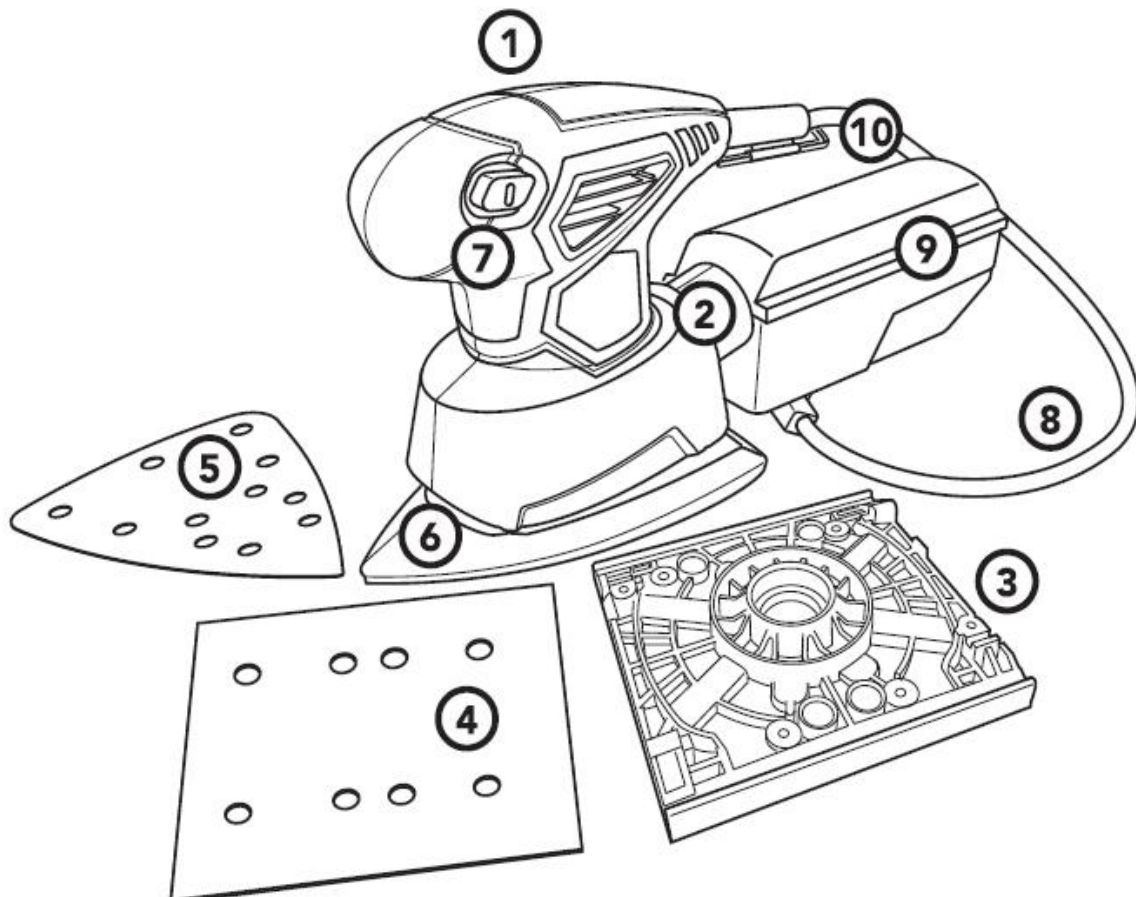

- ① Handle grip
- ② Dust extraction outlet
- ③ Rectangular hook & Loop base
- ④ Rectangular sanding pad
- ⑤ Triangular sanding pad
- ⑥ Triangular hook & Loop base
- ⑦ On/off (I/O)slide switch
- ⑧ Power cord
- ⑨ Dust box
- ⑩ Hex key holder & Key

b. Technical data

Model	RACPDEL130
voltage	230-240 V [~] ,50 Hz
Power	130W
Protection class	II
Degree of protection	IP20
Vibration speed	14000/min
Dimensions of the sanding pad	□ :100x110mm
	△:100x150
Plug type	VDE, 2m cable

Vibration and noise emission

Sound pressure level: 76 dB(A), K=3 dB

Sound power level: 87 dB(A), K=3 dB

Vibration: ah=3.017 m/s², K=1,5m/s²

Information:

- The declared vibration total value has been measured in accordance with a standard test method and may be used for comparing one tool with another;
- The declared vibration total value may also be used in a preliminary assessment of exposure.

Warning:

- that the vibration emission during actual use of the power tool can differ from the declared total value depending on the ways in which the tool is used; and
- of the need to identify safety measures to protect the operator that are based on an estimation of exposure in the actual conditions of use (taking account of all parts of the operating cycle such as the times when the tool is switched off and when it is running idle in addition to the trigger time).

Wear hearing protection.

3. USE

Fitting the sandpaper

IMPORTANT: Switch off the tool and unplug the power cord before fitting the sandpaper.

- Using the correct punched Hook and Loop Sanding Sheet, align the holes with those in the HOOK AND LOOP BASE (3,6).
- The sandpaper pad has a Velcro surface for the quick attachment of sandpaper. Brush off any dust from the Velcro surface.
- Smooth the sandpaper onto the pad.
- Align the holes in the sandpaper with the holes in the pad. This will ensure that the dust extraction function operates correctly.

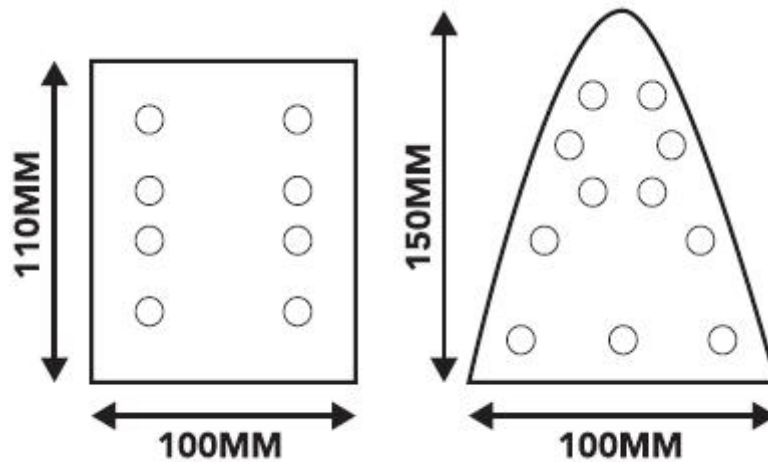

Dust extraction

Slide the DUSTBOX (9) onto the DUST EXTRACTION OUTLET (2).

CAUTION: Always wear a suitable breathing mask when operating this tool. All wood and paint dust is hazardous to health and may also be toxic.

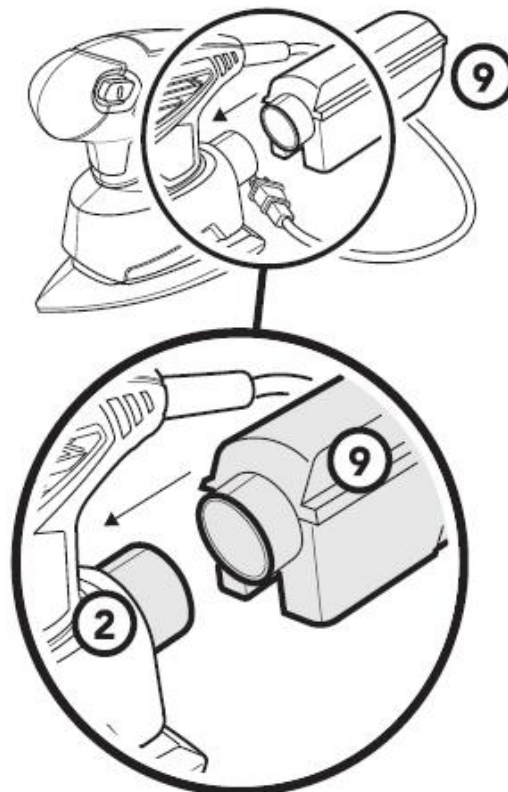

Starting/stopping

WARNING! Never switch on the Sander whilst the HOOK AND LOOP SANDING BASE (3) is in contact with the workpiece or any other surface as this may cause the operator to lose control over the tool and could result in serious injury.

CAUTION: Always hold the Sander securely by the Soft Grip Handle.

Connect the Sander to the mains power supply.

To start the tool, press the ON/ I SLIDE SWITCH(7) to slide it to the right side.

To stop the tool, press the OFF/O SLIDE SWITCH (7) to slide it to the left side.

WARNING! Always wait until the tool has stopped vibrating completely before putting it down. Always disconnect from the power supply after use.

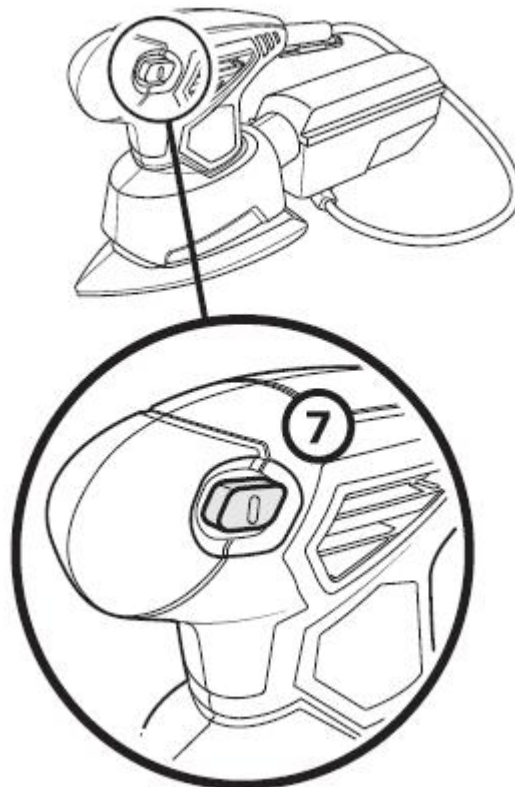

Sanding

- Place the sanding surface flush with workpiece.
- Start the tool and move it over the workpiece with circular movements. Do not press the tool. The weight of the tool normally produces the right speed and sanding action. Avoid tilting the tool.
- Continue sanding with finer grades of sandpaper.

Polishing

- Apply the polish evenly, allow to dry and then start polishing.
- When you have finished, lift the tool slowly from the workpiece before switching off.

Changing hook & Loop based

- Turn the 2 in 1 Sander upside down.
- Use the HEX KEY (10) provided to unscrew the 4 Hook & Loop Base screws.
- Remove the HOOK & LOOP BASE (3,6).
- To re-attach, place the desired HOOK & LOOP BASE (3,6) onto the 2 in 1 Sander and secure with the Hook & Loop Base screws.

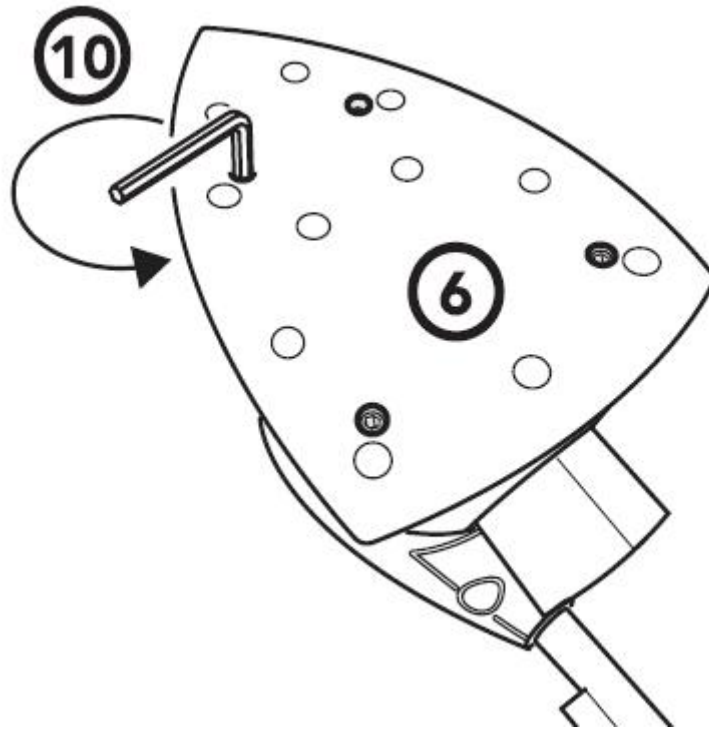

4. MAINTENANCE

- Clean the dust extraction holes regularly with a dry brush.
- Clean the casing with a damp cloth. Do not use solvents. Wipe dry.
- Remove the dust bag and carefully empty it. Avoid inhaling wood dust. Wash the dust bag in cold soapy water and allow to dry.
- Check before use that the tool, power cord, plug and accessories are intact and undamaged. The tool must only be repaired by an authorised service centre or other qualified personnel.
- Products that have reached the end of their useful life must be disposed of in accordance with local regulations.

5. TROUBLESHOOTING

PROBLEM	SOLUTION
THE TOOL WILL NOT START	Ensure the tool is switched on and connected to mains power. Activate the "ON/OFF" Switch. Check the fuse and replace.
THE TOOL KEEPS KICKING/STALLING	Relieve some pressure on the tool, do not exert extra force. Let the tool do the job.
EXCESSIVE VIBRATION	The material is too thick and is placing strain on the motor. If excessive noise continues, discontinue use and seek repairs.
EXCESSIVE NOISE	Too much force is being exerted on the tool. Use less force.
THE TOOL IS OVERHEATING	Allow the tool to cool before using again

6. DISPOSAL



recycling.

Electrical products should not be discarded with household products. According to the European Directive 2012/19/EU on waste electrical and electronic equipment and its implementation into national law, electrical products used must be collected separately and disposed of at collection points provided for this purpose. Talk with your local authorities or dealer for advice on

7. CE DECLARATION



BUILDER SAS

ZI, 32, rue Aristide Bergès – 31270 Cugnaux - France

Tel : +33 (0)5.34.502.502 Fax : +33 (0)5.34.502.503

States that the designated below machine:

Product: Delta sander 130 W

Model: RACPDEL130

Serial number: 20210350153-20210353652

Developed, designed and manufactured in accordance with the requirements of directives:

Machinery Directive 2006/42/EC

EMC Directive 2014/30/EC

ROHS Directive 2011/65/EU+(EU)2015/863

Also meets the following standards:

EN 62841-1:2015+AC:2015

EN 62841-2-4:2014

EN 55014-1:2017

EN 55014-2: 2015

EN 61000-3-2: 2014

EN 61000-3-3:2013

Cugnaux, 15/12/2020

Philippe MARIE / PDG



Responsible of the technical file: Olivier Patriarca

8. WARRANTY



WARRANTY

The manufacturer guarantees the product against defects in material and workmanship for a period of 2 years from the date of the original purchase. The warranty only applies if the product is for household use. The warranty does not cover breakdowns due to normal wear and tear.

The manufacturer agrees to replace parts identified as defective by the designated distributor. The manufacturer does not accept responsibility for the replacement of the machine, in whole or in part, and/or ensuing damage.

The warranty does not cover breakdowns due to:

- insufficient maintenance.
- abnormal assembly, adjustment or operations of the product.
- parts subject to normal wear and tear.

The warranty does not extend to:

- shipping and packaging costs.
- using the tool for a purpose other than that for which it was designed.
- the use and maintenance of the machine done in a manner not described in the user manual.

Due to our policy of continuous product improvement, we reserve the right to alter or change specifications without notice. Consequently, the product may be different from the information contained therein, but a modification will be undertaken without notice if it is recognized as an improvement of the preceding characteristic.

READ THE MANUAL CAREFULLY BEFORE USING THE MACHINE.

When ordering spare parts, please indicate the part number or code, you can find this in the spare parts list in this manual. Keep the purchase receipt; without it, the warranty is invalid. To help you with your product, we invite you to contact us by phone or via our website:

- **+33 (0)9.70.75.30.30**
- **<https://services.swap-europe.com/contact>**

You must create a "ticket" via the web platform.

- Register or create your account.
- Indicate the reference of the tool.
- Choose the subject of your request.
- Describe your problem.
- Attach these files: invoice or sales receipt, photo of the identification plate (serial number), photo of the part you need (for example: pins on the transformer plug which are broken).



9. PRODUCT FAILURE

WHAT TO DO IF MY MACHINE BREAKS DOWN?

If you bought your product in a store:

- a) Empty the fuel tank.
- b) Make sure that your machine is complete with all accessories supplied, and clean! If this is not the case, the repairer will refuse the machine.

Go to the store with the complete machine and with the receipt or invoice.

If you bought your product on a website:

- a) Empty the fuel tank.
- b) Make sure that your machine is complete with all accessories supplied, and clean! If this is not the case, the repairer will refuse the machine.
- c) Create a SWAP-Europe service ticket on the site: <https://services.swap-europe.com> When making the request on SWAP-Europe, you must attach the invoice and the photo of the nameplate (serial number).
- d) Contact the repair station to make sure it is available before dropping off the machine.

Go to the repair station with the complete machine packed, accompanied by the purchase invoice and the station support sheet downloadable after the service request is completed on the SWAP-Europe site

For machines with engine failure from manufacturers BRIGGS & STRATTON, HONDA and RATO, please refer to the following instructions.

Repairs will be done by approved engine manufacturers of these manufacturers, see their site:

- <http://www.briggsandstratton.com/eu/fr>
- <http://www.honda-engines-eu.com/fr/service-network-page;jsessionid=5EE8456CF39CD572AA2AEEDFD290CDAE>
- <https://www.rato-europe.com/it/service-network>

Please keep your original packaging to allow for after-sales service returns or pack your machine with a similar cardboard box of the same dimensions.

For any question concerning our after-sales service you can make a request on our website <https://services.swap-europe.com>

Our hotline remains available at +33 (9) 70 75 30 30.



10. WARRANTY EXCLUSIONS

THE WARRANTY DOES NOT COVER:

- Start-up and setting up of the product.
- Damage resulting from normal wear and tear of the product.
- Damage resulting from improper use of the product.
- Damage resulting from assembly or start-up not in accordance with the user manual.
- Breakdowns related to carburetion beyond 90 days and fouling of carburetors.
- Periodic and standard maintenance events.
- Actions of modification and dismantling that directly void the warranty.
- Products whose original authentication marking (brand, serial number) has been degraded, altered or withdrawn.
- Replacement of consumables.
- The use of non-original parts.
- Breakage of parts following impacts or projections.
- Accessories breakdowns.
- Defects and their consequences linked to any external cause.
- Loss of components and loss due to insufficient screwing.
- Cutting components and any damage related to the loosening of parts.
- Overload or overheating.
- Poor power supply quality: faulty voltage, voltage error, etc.
- Damages resulting from the deprivation of enjoyment of the product during the time necessary for repairs and more generally the costs related to the immobilization of the product.
- The costs of a second opinion established by a third party following an estimate by a SWAP-Europe repair station
- The use of a product which would show a defect or a breakage which was not the subject of an immediate report and/or repair with the services of SWAP-Europe.
- Deterioration linked to transport and storage*.
- Launchers beyond 90 days.
- Oil, petrol, grease.
- Damages related to the use of non-compliant fuels or lubricants.

* In accordance with transport legislation, damage related to transport must be declared to carriers within 48 hours maximum after observation by registered letter with acknowledgement of receipt.

This document is a supplement to your notice, a non-exhaustive list.

Attention: all orders must be checked in the presence of the delivery person. In case of refusal by the delivery person, it you must simply refuse the delivery and notify your refusal.

Reminder: the reserves do not exclude the notification by registered letter with acknowledgement within 72 hours.

Information:

Thermal devices must be wintered each season (service available on the SWAP-Europe site). Batteries must be charged before being stored.