



**4 TROKE PETROL CHAIN SAW**  
**RAC49CS4T**  
**USER GUIDE**

CAUTION: Read the instructions before using the machine.

# CONTENTS

1. SAFETY INSTRUCTIONS .....	3
2. EXPLANATION OF SYMBOLS .....	7
3. INTENDED USE .....	8
4. SCOPE OF DELIVERY .....	8
5. KNOW YOUR PRODUCT .....	9
6. SET UP & OPERATION .....	31
7. CLEANING MAINTENANCE AND SERVICING .....	21
8. STORAGE & TRANSPORT .....	24
9. DISPOSAL AND RECYCLING .....	25
10. TROUBLESHOOTING .....	25
11. DECLARATION OF CONFORMITY .....	26
12. WARRANTY .....	27
13. PRODUCT FAILURE .....	28
14. WARRANTY EXCLUSIONS .....	29

# 1. SAFETY INSTRUCTIONS

## 1.1 GENERAL SAFETY FUNCTIONS

 **CAUTION!** When using machines, safety measures must be complied with in order to prevent injury and damage. Therefore, carefully read this operating manual/these safety notices. If you hand over the machine to others, please also pass on this manual/these safety notices. We are not liable for accidents or damage caused by non-compliance with this manual and these safety notices.

- **WARNING!** When using this type of tool, basic precautions should always be followed to reduce the risk of fire, electric shock and injury.
- Read all instructions carefully before attempting to use this product and retain these instructions. Be familiar with all the operations described in these operating instructions.
- This product must be operated and operated by experienced users.
- If you are giving this machine to others, please also provide them with this instruction's manual.
- Also read all markings on the product. The symbols on the tools are explained in the manual.
- Use this machine as described in this instruction manual. It is strictly forbidden to use this tool for applications other than those described in this manual.
- Failure to follow these instructions can result serious injuries and, in some cases, death.
- This product is intended for private domestic use only. Do not use it for commercial purposes.
- Never let people unfamiliar with these instructions or children use this product.
- National regulations may limit the use of the machine.
- People under the age of 18 must not use this product
- Keep in mind that the operator or user is responsible for accidents or risks to other persons or their property.
- Do not use the tool if you are drunk, tired, under the influence of drugs or ill. Do not use the tool if you are not in an adequate physical condition.
- This tool is intended for outdoor use. Never use it indoors
- When transporting the machine:
  - Secure the machine during transport to prevent loss of fuel, damage or injury
  - Use a carrying case to protect the cutter during transport.
  - Keep people and animals away from the work area. Children and people who do not know how to use this tool should not touch it and handle it.
  - Keep them at least 15 m from the machine during operation, Use the product only under daylight or under good artificial light.
- When using the machine, always wear full protective equipment including a helmet, protective mask, ear protection, gloves, non-slip footwear and protective clothing.
- Wear appropriate clothing. Do not wear loose or unbuttoned shirts. Do not wear jewellery that may come in contact with moving parts. If you have long hair, tie them down and wear an appropriate safety helmet.
- Do not operate the product with damaged guards or shields not in place.
- Always keep hands and feet of the appliance and especially when turning the appliance off and on.
- Do not use the tool in an area where ventilation is poor. Gas emissions can cause injury.
- Do not work when it rains and in bad weather. Do not use the tool in damp locations
- Do not use the tool in the presence of flammable liquids or gases.
- Caution: The machine releases gases when it is used. Avoid encountering these gases
- Keep the work area clear. Before working, inspect the work area and remove any materials or objects that could cause accidents.
- Do not force the tool.
- Use only the accessories supplied or recommended by the manufacturer. Use of other accessories may result in an accident. Read the "Technical Data" section of this instruction manual or ask your dealer for advice.
- Do not lean. Always keep a good seating and balance.
- To maintain tools and accessories carefully, keep cutting tools sharp and clean for better and safer performance. Follow the instructions in this manual to lubricate and change accessories.
- Always inspect the machine before and after operation. If the tool is damaged or faulty, stop using the tool and bring it to an authorized service for inspection and repair.
- Turn off the tool after use, when you leave it unattended, when changing these accessories and before

servicing.

- Keep handles dry, clean and free from oil and grease.
- Be concentrated when using the tool. Look at what you do, make sense and do not use the tool when you are tired.
- Remove the blade guard before using the tool.
- A damaged guard or other part must be properly repaired or replaced by an authorized service center, unless otherwise specified in this instruction manual.
- Do not use the tool if the starter is not working (if it cannot be turned ON and OFF).
- Place the equipment in a well-lit area on a flat, stable, dry and well-ventilated surface, away from flammable materials and with plenty of space for sparking and sharpening waste.
- Do not allow anyone, especially children, to come within a radius of at least fifteen meters around the work area when all work is in progress.
- Immediately stop the tool in the event of a malfunction of the motor or the ON/OFF button or in case of unusual noise.
- Do not use the tool if the starter is damaged.
- Do not move the chain with your hand with the wheel moving.
- Do not stop the chain with your hands or other objects.
- Treat the chain teeth with caution during operation; they can cause severe cuts.
- When not in use, the machine must be stored in a dry, locked place out of the reach of children.
- Before using the product and after any shock, please check it for signs of wear or damage. Please carry out repairs if necessary.
- Always switch off the machine:
  - Every time you leave the device unattended;
  - Before releasing an obstruction;
  - before checking, cleaning or working on the product;
  - after hitting a foreign object;
  - Every time the product starts to vibrate abnormally.
- Pay attention to foot and cutting injuries.
- Inspect and regularly service the product. Repairs should be carried out only by an authorized service center or a similar qualified specialist.
- When not in use, store the product out of the reach of children.
- Children should not play with plastic bags, sheets and small parts! Keep them out of the reach of children. There is a danger of suffocation!
- When transporting the tool, always add the blade guard to the blade. Always carry the tool by holding the handle, never the blade.
- Do not use the product on a slippery surface.
- Do not use the product on steep, slippery slopes.
- When planning your work schedule, allow enough time for rest. Limit continuous use of the device e.g. use 30 ~ 40 minutes per session and take 10 ~ 20 minutes of rest between work sessions. Work a maximum of two hours per day
- If the machine has struck foreign objects, check if the tool is damaged and bring it to repair if necessary.
- Do not place any part of the body on the chain when the chainsaw is operating. Before starting the chain saw, make sure that the chain is not in contact with anything. A moment of inattention during use may cause your clothing or body part to stick to the chain.
- Always hold the chainsaw back handle with your right hand and the front handle with your left hand. Hold the chainsaw by inverting your hands increases the risk of personal injury and should never be used.
- For the chainsaw designed with the chain guide on the left side, the reference to the "right hand" and "left hand" positions is reversed.
- When cutting a branch that is under stress, pay attention to the risk of elastic return.
- When the tension of the wood fibres is released, the spring-loaded limb may strike the operator and / or project the chain saw out of control.
- Exercise extreme caution when cutting brush and young shrubs. Fine materials can grip the cutting chain and be thrown as a whip in your direction, or you lose balance under the effect of traction.
- Follow the instructions for lubrication, tension and chain change accessories. A chain whose tension and lubrication are incorrect can either break or increase the risk of rebound.
- Keep handles dry, clean and free of oil and grease. Oily, greasy grips are slippery and cause loss of control.
- Cut only wood, as well as for pruning and cutting wood. Do not use the chain saw for any other purpose.

For example: do not use it to cut plastic, masonry or construction materials other than wood. Using the chain saw for operations other than those specified may result in hazardous situations.

- Be careful when using the machine during stormy weather. Do not use the machine during lightning, thunderstorms or in bad weather in general.
- There is advantage of using the provided spiked bumper when cutting trees and thick branches.
- Perform regular functional check of the clutch. It should be no have chain movement at idling speed.
- When operating the tool, be careful of the emission of exhaust gases, lubrication oil mist and saw dust; avoid being exposed to these and wear protective equipment.
- Wear protective gloves when assembly, disassembly, sharpening chain tensioning and when handling the guide bar.
- Guide-bar and chain adjustments shall be performed with the engine stopped.
- Regularly check and test the chain brake.
- Hazards may be encountered while using the saw, such as blockage of the saw chain. In order to reduce hazards, follow the instruction for cutting operation; always check the condition of the tool. Do not start the chainsaw directly in a tree.

## 1.2 FUEL HANDLING

- Be very careful when handling fuels. They are flammable and the vapors are explosive.
- Use only an approved container.
- Never remove the fuel cap or add fuel while the machine is on. Turn off the unit and allow the engine and exhaust components to cool before refuelling.
- Do not smoke.
- Never refuel inside a room
- Never store the tool and the fuel tray indoors where there is a naked flame, such as near a water heater.
- If fuel has spilled, do not attempt to start the machine, but rather move it away from the spill before starting to use it. Clean any spills.
- Replace and tighten the fuel tank cap after refuelling.
- Follow the instructions in this manual for filling the tool with fuel.

## 1.3 MAINTENANCE AND STORAGE

- Stop the tool and wait until it stops. Make sure all moving parts have come to a standstill.
- Allow the machine to cool before performing inspection, adjustments, maintenance, servicing and storage.
- Store the tool where fuel vapor will not reach a flame or spark.
- When transporting and storing, always place the tool in its transport guard and protective device on it.

## 1.4 CAUSES OF REBOUNDS AND PREVENTION BY THE OPERATOR

- Bounce may occur when the spout or end of the chain guide touches an object, or when the wood tightens and pinches the cutting chain in the cutting section.
- The contact of the tip may in some cases cause a sudden reverse reaction by bouncing the chain guide up and back towards the operator.
- Pinching of the cutting chain on the upper part of the chain guide can force the chain guide to the operator abruptly.
- Either of these reactions can result in loss of control of the saw likely to result in a serious personal injury. Do not rely exclusively on safety devices built into your saw. As a chain saw user, all measures should be taken to eliminate the risk of accident or injury during cutting.
- Bounce results from improper use of the tool and / or incorrect operating procedures or conditions and can be avoided by taking the appropriate precautions specified below:
  - Hold the saw with both hands firmly with the thumbs and fingers encircling the handles of the saw and place your body and arms to allow you to withstand the rebound forces. The rebound forces can be controlled by the operator, if appropriate precautions are taken. Do not allow chain saw to start.
  - Do not stretch the arm too far and do not cut above the shoulder height. This helps prevent unintentional end contacts and allows better control of the chain saw in unforeseen situations.
  - Use only the manufacturers specified replacement guides and chains. Incorrect replacement guides and chains may cause chain breakage and / or rebound.
  - Follow manufacturer's instructions for sharpening and servicing the chain saw. A decrease in the depth gauge level can lead to an increase in rebounds.

## 1.5 RESIDUAL RISKS

Even if you use this product in accordance with all safety requirements, the potential risks of injury and damage remain. The following hazards may occur as a result of the structure and design of this product:

- There are adverse health consequences resulting from the emission of vibrations if the product is used for long periods of time or not properly managed and properly maintained. Wear hearing protection.
- There is a risk of injury and damage to property due to the sudden impact on hidden objects.
- There is a risk of hearing loss with prolonged use, especially if hearing protection is not worn. Always wear hearing protection and limit the operating time.
- Cuts if no suitable protective equipment is worn.
- Inhalation of particles and exhaust gases if no protective mask is worn.
- Risk of bodily injury and material damage resulting from flying objects.
- Prolonged use of this product exposes the operator to vibration and may produce "white finger" disease. In order to reduce the risk, please wear gloves and keep your hands warm. If any of the symptoms of "white finger" syndrome appear, seek medical attention immediately. Symptoms of "white finger" include:
  - Numbness, loss of sensitivity, tickling, tingling,
  - Pain, loss of strength, changes in colour or condition of the skin.

These symptoms usually appear on the fingers, hands, or wrists. The increased risk during cold weather.

## 1.6 REFUELLING

- 1) Turn off the engine before refueling. Always open the fuel tank cap carefully so that the existing pressure can be released slowly.
- 2) High temperatures are generated on the machine body during use. Before refueling, allow the machine to cool completely. If the machine has not cooled sufficiently, fuel can ignite during refueling and cause severe burns.
- 3) Make sure the tank is not overfilled. If you spill any fuel, it should be wiped up immediately and the machine cleaned.
- 4) Always properly close the threaded cap on the fuel tank, in order to avoid loosening of vibrations during operation. Never refuel the machine near an open flame.

## 1.7 SAFETY FUNCTIONS OF THE CHAINSAW

### **SAW CHAIN WITH LOW KICKBACK**

helps significantly reduce kickback, or the intensity of kickback, due to specially designed depth gauges and guard links.

### **CHAIN BRAKE LEVER / FRONT HAND GUARD**

protects the operator's left hand in the event it slips off the front handle while saw is running.

### **CHAIN BRAKE**

is a safety feature designed to reduce the possibility of injury due to kickback by stopping a moving saw chain in milliseconds. It is activated by the CHAIN BRAKE LEVER.

### **SAFETY LOCK**

prevents accidental acceleration of the engine. Throttle lever (7) cannot be squeezed unless the safety latch is depressed.

### **STOP SWITCH**

immediately stops the engine when actuated. Stop switch must be pushed to position "I" to start or restart the engine.

### **CHAIN GUARD**

fitted when the engine is stopped, prevents the danger of cutting injury from the chain teeth.

### **CHAIN CATCHER**

reduces the danger of injury in the event saw chain breaks or derails during operation. The chain catcher is designed to intercept a whipping chain.













### **NOTICE**

Familiarise yourself with the saw and its components.

## 2. EXPLANATION OF SYMBOLS

The use of symbols in this manual is intended to draw your attention to possible risks.

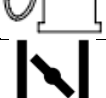
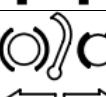
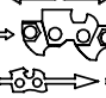
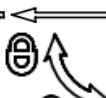
The safety symbols and the explanations that accompany them must be perfectly understood. The warnings in themselves do not remove the risks and cannot replace correct actions for preventing accidents.

	Read, understand and follow all warnings.
	<b>WARNING!</b> Chance of kickback. Beware of a check of the chain saw and avoid contact with the tip of the bar
	Do not use the device with one hand
	Use the device with both hands
	Always wear safety glasses, hearing protection and a safety helmet
	Read the complete user guide before using the appliance
	Wear security and anti-vibration gloves when you use the device
	Always wear non-skid safety shoes with cut protection when using this product
	It is important you wear the protection clothing for feet, legs, hands and forearms
	Fuel filler cap
	Choke knob
	Setting the chain tension
	Installation direction of chain
	Bar fastening pin
	Conforms to relevant safety standards
	Guaranteed sound power level of the appliance



## 3. INTENDED USE

The chainsaw is designed exclusively for sawing wood.

You may only fell trees if you have received the appropriate training.

The manufacturer cannot be held liable for damage caused by improper or incorrect usage.

### **DO NOT operate a chainsaw whilst working in a tree.**

The machine is to be used only for its prescribed purpose. Any other use is deemed to be a case of misuse. The user / operator and not the manufacturer will be liable for any damage or injuries of any kind caused as a result of this.

Please note that our equipment has been designed for personal domestic use only and has not been designed for use in commercial, trade or industrial applications.

Our warranty will be voided if the machine is used in commercial, trade or industrial businesses or for equivalent purposes.

The operating instructions as supplied by the manufacturer must always be followed to ensure that the equipment is used properly. Any use which is not expressly permitted in the manual may result in damage to the equipment and place the user in danger. Observe the restrictions in the safety instructions.

### **⚠ DANGER**

**Cut only wood with this chainsaw. Due to the high risk of physical injury to the user, the equipment must not be used for purposes which it was not intended. For example, do not use the chainsaw for cutting plastic, masonry, or non-wood building materials.** For safety reasons, the equipment is not allowed to be used as a drive unit for other tools of any kind.

### **Non-permitted users**

Persons who are not familiar with the operating manual, children, young people under the age of 16 as well as persons under the influence of alcohol, drugs or medication do not operate the unit.

## 4. SCOPE OF DELIVERY

Chainsaw 4-Stroke (1x)

Chain bar (1x)

Saw Chain (1x)

Spark plug spanner (1x)

Chain guard (1x)

SWAP leaflets

Instruction manual (1x)

- Open the packaging and take out the equipment with care.
- Remove the packaging material.
- Check that all listed contents are present.
- Inspect the equipment and parts for any damage. Please contact the helpline if anything is missing.
- If possible, keep the packaging until the end of the guarantee period.
- Read the operating instructions fully to familiarise yourself with the tool prior to using it.
- Only use original accessories and spare parts. Spare parts are available by contacting the helpline.
- Specify the part numbers when you contact the helpline.

**The device and packaging materials are not toys!**

**Children must not be allowed to play with plastic bags, film and small parts!**

**There is a risk of swallowing and suffocation!**



# 5. KNOW YOUR PRODUCT

## 5.1 LAYOUT

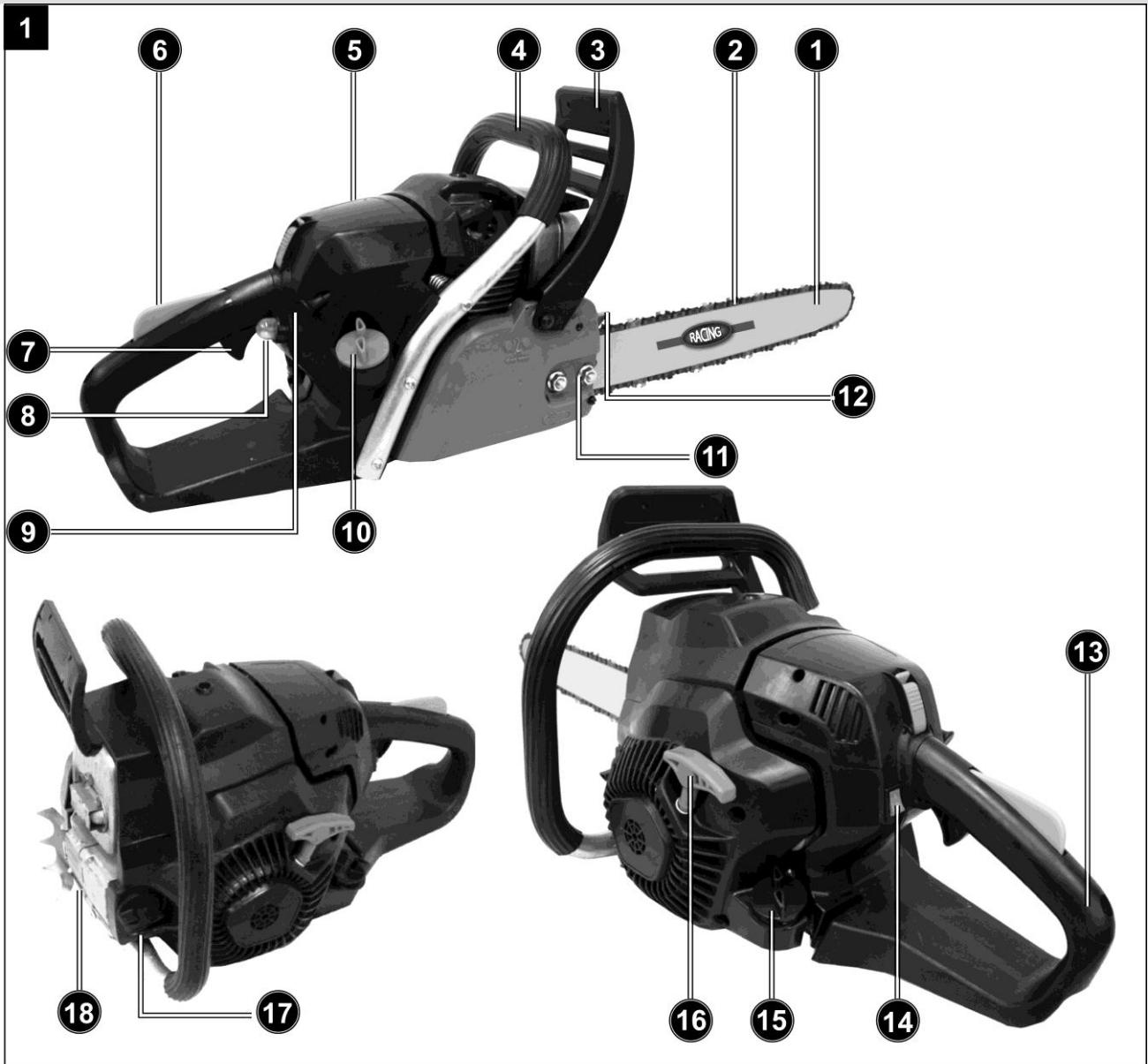

**(Fig. 1 / 1.1)**

- |  |                               |                         |
|--|-------------------------------|-------------------------|
| 1 Chain bar                            | 7 Throttle lever              | 14 Stop switch          |
| 2 Saw chain                            | 8 Fuel pump 'primer bubble'   | 15 Lubrication oil tank |
| 3 Chain brake lever / front hand guard | 9 Choke (carburettor setting) | 16 Starter handle       |
| 4 Front handle                         | 10 Fuel tank                  | 17 Chain oil tank       |
| 5 Air filter cover                     | 11 Bar mounting nuts          | 18 Chain catcher        |
| 6 Safety lock                          | 12 Spiked bumper              | 19 Spark plug spanner   |
|  | 13 Rear handle / bootstrap    | 20 Chain guard          |

**5.2 TECHNICAL DATA**

<b>Engine displacement</b>	49 cm <sup>3</sup>
<b>Maximum engine capacity</b>	1.6 kW
<b>Cutting length</b>	35 cm
<b>Maximal speed of the engine</b>	9500 min <sup>-1</sup>
<b>Chain and bar type</b>	Guide bar: AP16-57-507P 16" Chain: ALP-50-57S 16"
<b>Chain pitch</b>	(3/8"), 9.525 mm, 6 teeth
<b>Gauge</b>	1,27mm
<b>Idling speed</b>	2700-3800 min <sup>-1</sup>
<b>Maximum cutting speed</b>	18.1 m/s
<b>Fuel tank capacity</b>	400 cm <sup>3</sup> / 0.4 L
<b>Lubricating tank capacity</b>	100 cm <sup>3</sup> / 0.1 L
<b>Chain oil tank capacity</b>	300 cm <sup>3</sup> / 0.3 L
<b>Anti-vibration function</b>	Yes
<b>Chain brake</b>	Yes
<b>Clutch</b>	Yes
<b>Automatic chain lubrication</b>	Yes
<b>Low-kickback chain</b>	Yes
<b>Net weight without chain and chain bar (dry)</b>	5.3 kg
<b>Sound pressure level LpA</b>	101.28 dB(A)
<b>Uncertainty KpA</b>	2.5 dB(A)
<b>Guaranteed sound power level LwA</b>	110 dB(A)
<b>Measured sound power level LwA</b>	109.09dB(A)
<b>Uncertainty KwA</b>	0.61 dB(A)
<b>Vibration front handle ah</b>	10.589 m/s <sup>2</sup>
<b>Vibration rear handle ah</b>	9.396 m/s <sup>2</sup>
<b>Uncertainty K</b>	1.5 m/s <sup>2</sup>

# 6. SET UP & OPERATION

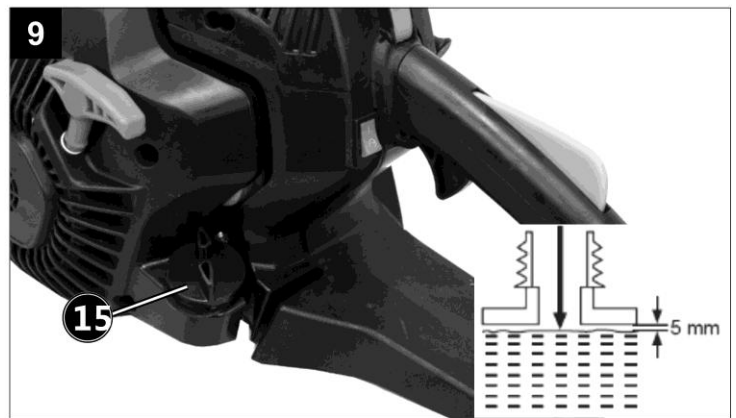
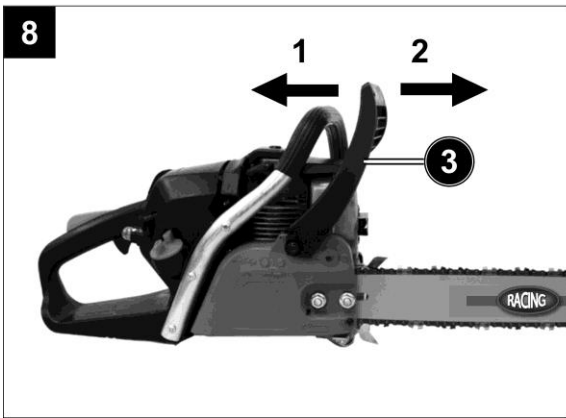
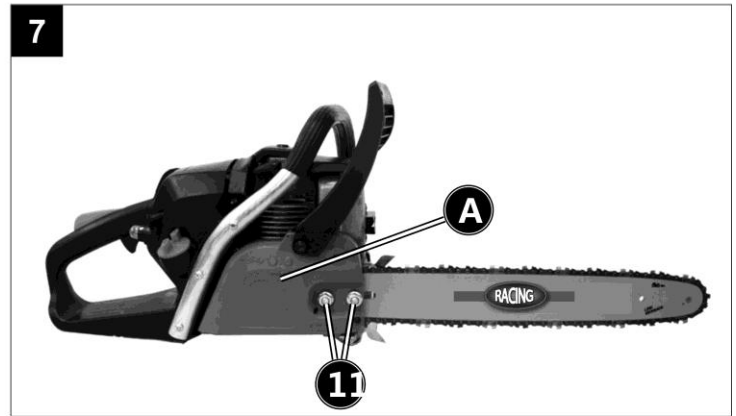
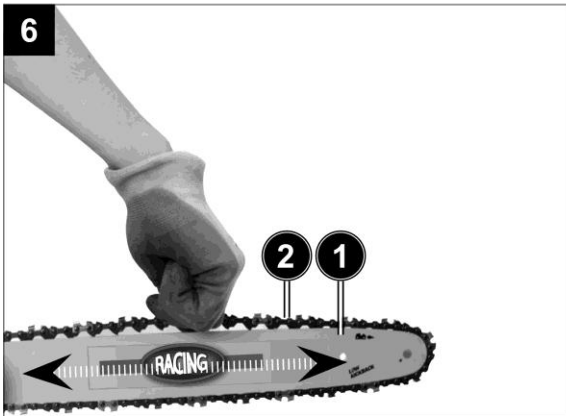
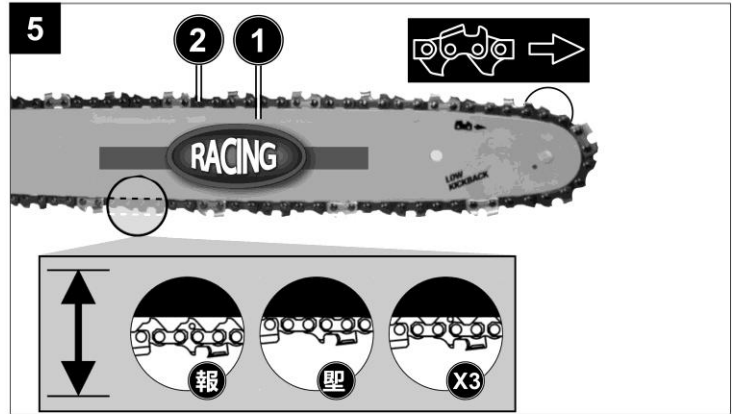
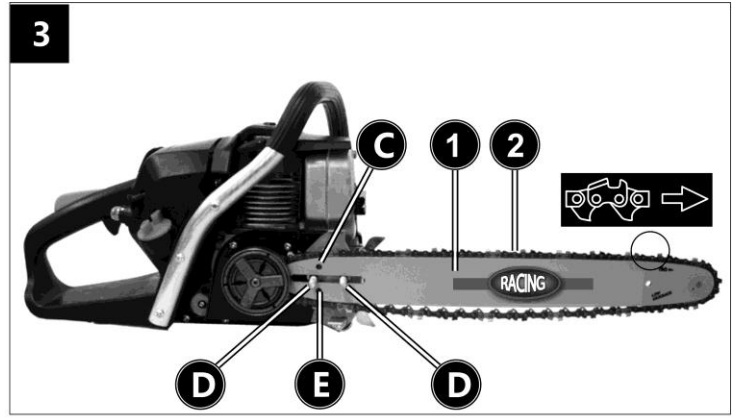
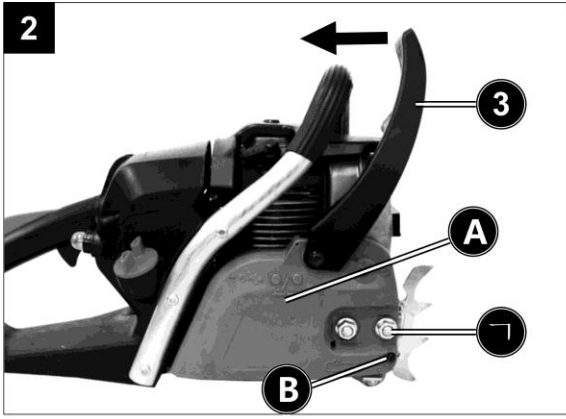

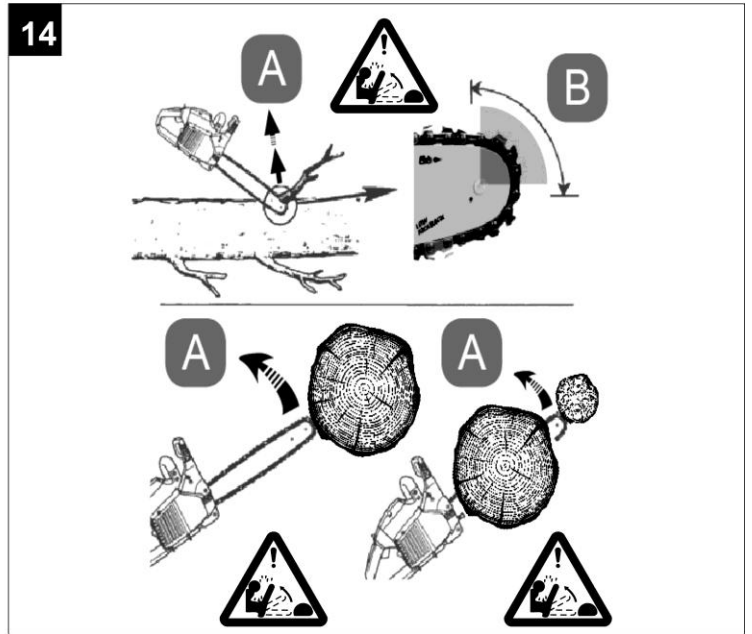
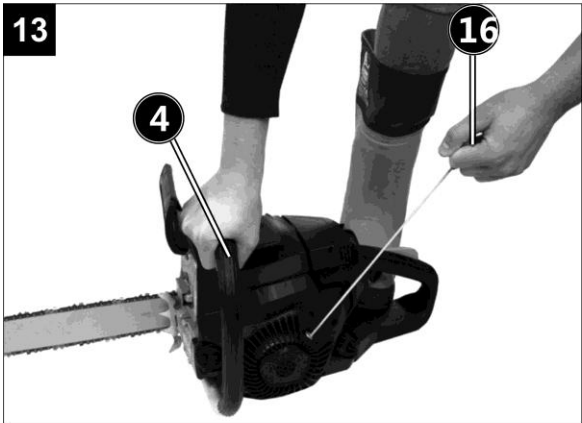
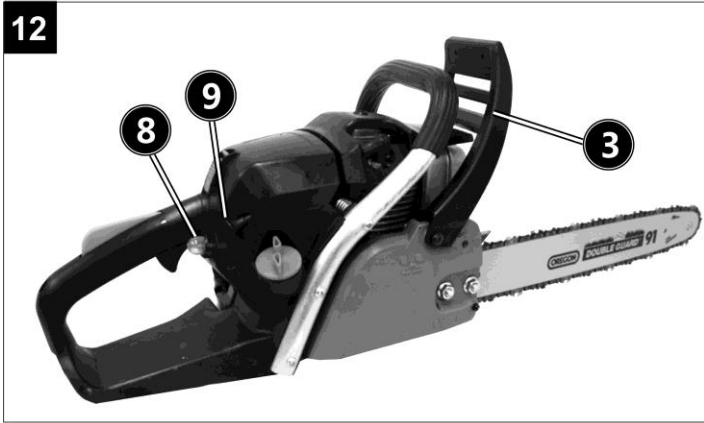
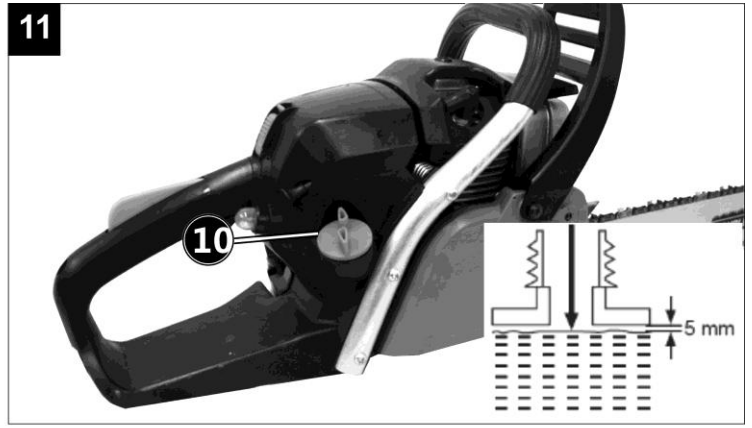
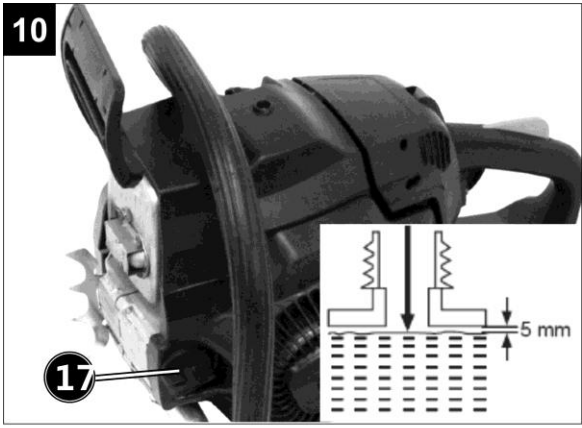

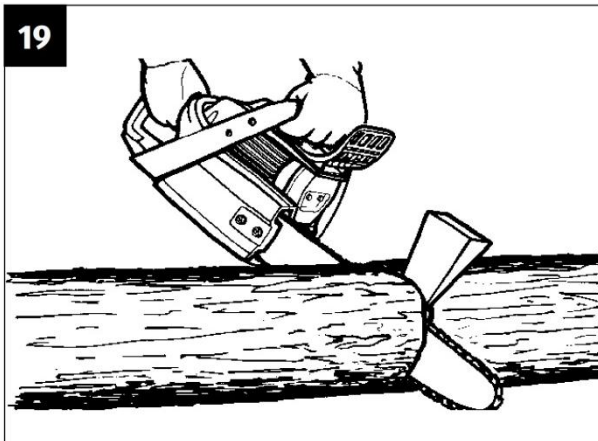
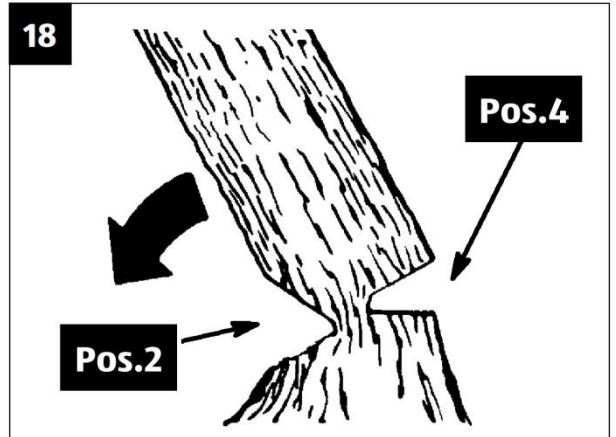
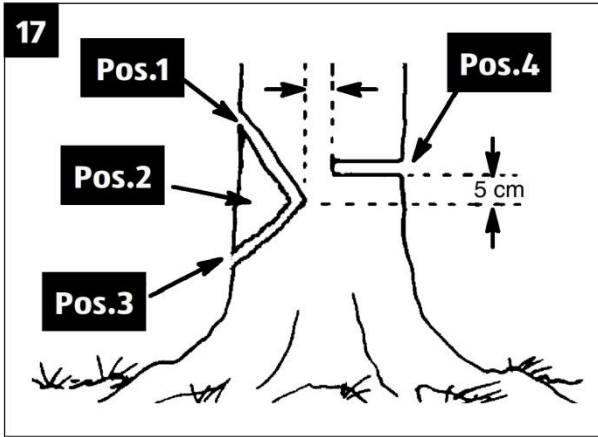
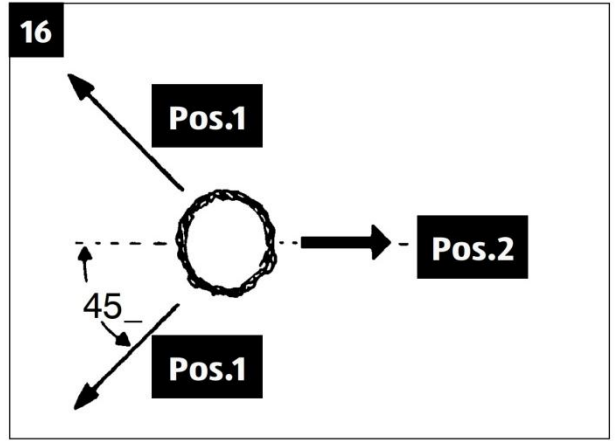
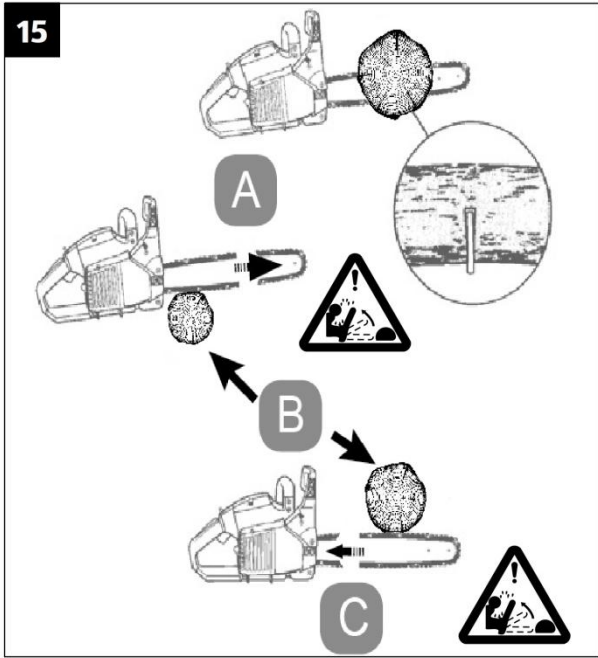



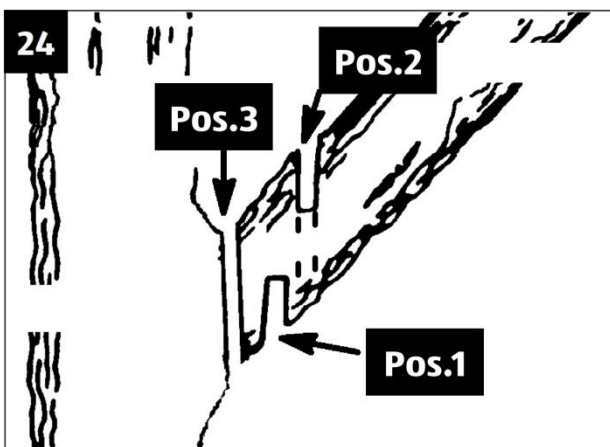
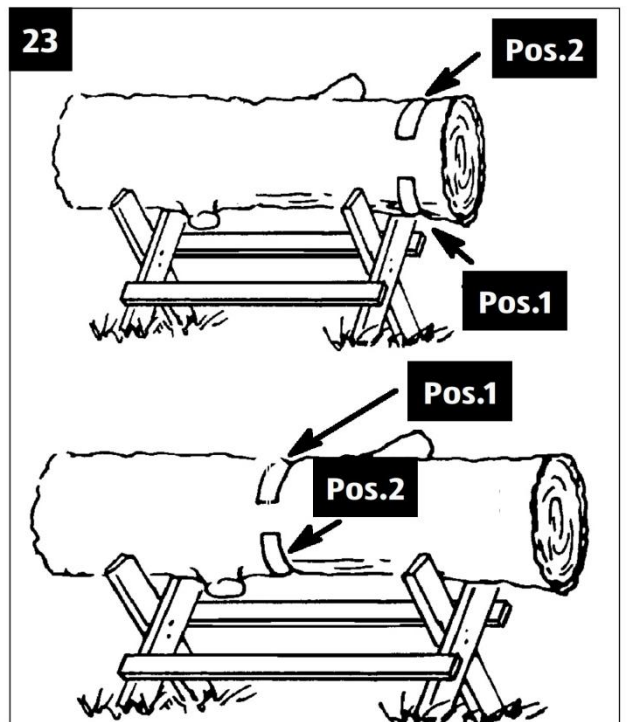
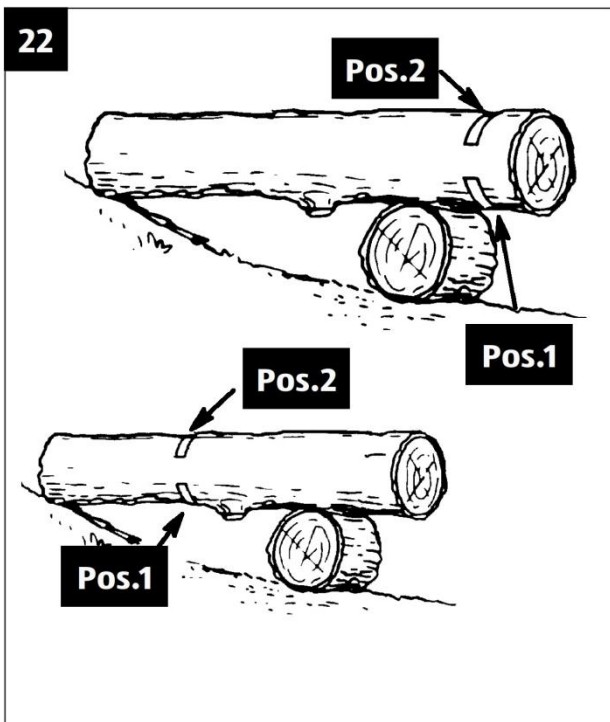
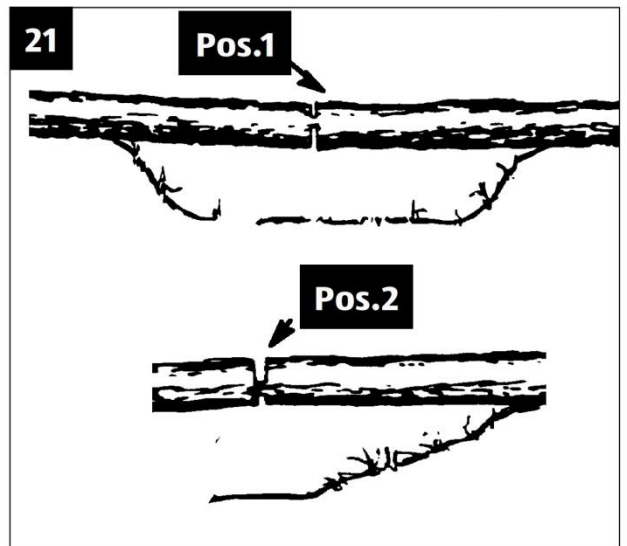
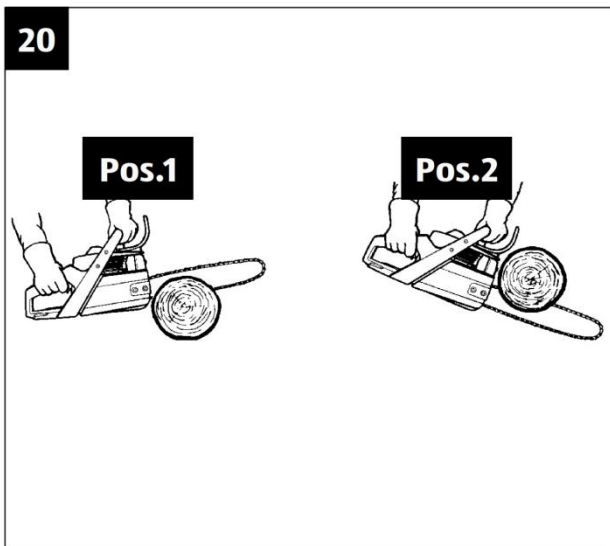

**⚠ NOTICE**

This chainsaw uses a 4-stroke engine and does not require the mixing of oil with the fuel. The chainsaw is fitted with ONE lubrication oil tank (15) and ONE chain oil tank (17) and a SEPARATE fuel tank (10).

## 6.1 ASSEMBLY OF THE CHAIN BAR AND CHAIN TO THE ENGINE UNIT

### CAUTION

Do not start the engine until the saw is fully assembled.

### CAUTION

Always wear protective gloves when handling the chain.

#### 1) Remove the side cover (Fig. 2)

- Make sure the chain brake lever / front hand guard (3) is pulled back into the **DISENGAGED** position.
- Remove the bar mounting nuts (11) with the spark plug spanner (19).
- Pull the whole side cover (A) from the engine.

#### 2) Fit the chain bar (Fig. 2 / 3)

To ensure that the bar and the chain are supplied with oil, **USE ONLY THE ORIGINAL BAR**. The oiling hole (C) must be kept clear of dirt and any build-up of residue.

- Make sure the chain brake lever / front hand guard (3) is pulled back into the **DISENGAGED** position.
- Fit the open end of the chain bar (1) over the bar pins (D).

#### 3) To install the saw chain (Fig. 2 / 3 / 4)

- Spread the saw chain (2) out in a loop with the cutting edges pointing **CLOCKWISE** around the loop.
- Slip the saw chain (2) around the sprocket behind the clutch as shown in figure 3. Make sure the links fit between the sprocket teeth.
- Guide the drive links into the groove and around the end of the chain bar (1).

### NOTICE

The saw chain may droop slightly on the lower part of bar.  
This is normal.

- Pull the chain bar (1) forward until the saw chain (2) is closely seated. Make sure that all the drive links are in the groove of the chain bar (1).
- Align the pin (F) at the inner side of the side cover (A) such that it fits into the hole of the chain bar (E).
- Turn the bar fastening pin (B) clockwise with the spark plug spanner (19). The saw chain (2) is not allowed to slip off the chain bar (1) when you do this. Only loosely tighten the bar fastening pin (B) at this stage and then follow the instructions for adjusting the chain tension as described in the section.

#### 4) Adjusting the chain tension

The correct tension of the saw chain is extremely important and must be checked before starting and periodically during all sawing work. If you take time to adjust the saw chain correctly, you will be able to make better cuts and the life of the chain will be prolonged.

- Hold the tip of the chain bar (1) upwards and turn the bar fastening pin (Fig. 2/ pos. B) with the spark plug spanner (19) in a **CLOCKWISE DIRECTION** in order to increase the chain tension. If you turn the bar fastening pin (Fig. 2/pos. B) in an **ANTI-CLOCKWISE DIRECTION**, the chain tension will be reduced. Check that the chain is seated around the entire chain bar (Fig. 5/pos. X3).
- After making the adjustment and with the tip of the bar still upwards, tighten the bar fastening pin (Fig. 2/pos. B). The chain is correctly tensioned when it is closely seated and can be pulled right around by hand, when the chain brake lever (3) is released.

### WARNING

Always wear high-strength gloves when handling or adjusting the saw chain.

If the chain is hard to turn around the chain bar or jammed, it is too tightly tensioned. Make the following small adjustments:

- Undo the bar fastening pin (Fig. 2/pos. B) by 1/2 of a turn **ANTI-CLOCKWISE**. Then slacken the chain tension by slowly turning the bar fastening pin (Fig. 2/pos. B) in an **ANTI-CLOCKWISE DIRECTION** and then pull the saw chain (2) back and forth on the chain bar (1) (Fig. 6). Continue until the chain can be



moved smoothly but is still closely seated (Fig. 5/pos. X2). Increase the tension by turning the bar fastening pin (Fig. 2/pos. B) in a CLOCKWISE DIRECTION.

- When the saw chain is correctly tensioned, hold the tip of the bar upwards and completely tighten the bar fastening pin (Fig. 2/pos. B).
- Secure the side cover (A) with the bar mounting nuts (11), by using the spark plug spanner (19) (Fig. 7).
- A new saw chain stretches, requiring adjustment after as few as 5 cuts. This is normal with a new chain, and the interval between future adjustments will lengthen quickly.
- If the saw chain is TOO LOOSE or TOO TAUT, the drive wheel, chain bar, saw chain and crank shaft bearing will suffer premature wear. Fig. 5/pos. X2 shows the correct tension (when cold) and Fig. 5/pos. X3 shows the tension (when warm). Fig. 5/pos. X1 shows a chain that is too loose.

### 5) Chain brake mechanical test

Your chainsaw is equipped with a chain brake that reduces the possibility of injury due to kickback. The chain brake is activated if pressure is applied against the chain brake lever (3) when, as in the event of kickback, the operator's hand strikes the lever. When the chain brake is actuated, saw chain movement stops abruptly.

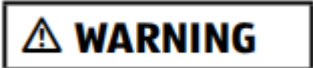

The purpose of the chain brake is to reduce the possibility of injury due to kickback; however, it cannot provide the intended measure of protection if the chainsaw is operated carelessly. Always test the chain brake before using your saw and periodically while on the job. (See below for details of how to perform a test of the chain brake).

### 6) To test chain brake (Fig. 8)

- The chain brake is DISENGAGED (chain can move) when the CHAIN BRAKE LEVER (3) IS PULLED BACK AND LOCKED (pos.1).
- The chain brake is ENGAGED (the chain is locked) when the chain brake lever (3) is pulled forward (pos. 2). It should not be possible to move the saw chain.

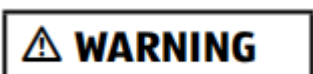

The chain brake lever (3) should snap into both positions. If strong resistance is felt, or the lever does not move into either position, do not use your chainsaw. Take it immediately to a professional Service Centre for repair.

## 6.2 FILLING/CHECKING THE LUBRICATING OIL (FIG. 9)

Following oil types are recommended:

Recommended Oil Type		
Season	Temperature	Oil Type
Summer	25 °C or higher	SAE 10W-30
Spring/Fall	10 - 25 °C	SAE 10W-20/30
Winter	10 °C or lower	SAE 10W-10

- Position the chainsaw in a way that the lubrication oil tank (15) faces upwards.
- Open the cap of the lubrication oil tank (15) and check the oil level. If the oil level is more than 1-2 cm below the screw thread, please fill the lubrication oil tank (15).
- Do not overfill and leave approximately 5 mm space between the top of the oil and the inside edge of the lubrication oil tank (15) to allow for expansion.
- Tighten the cap of the lubrication oil tank (15) firmly.

### 1) Filling/Checking the chain oil (Fig. 10)

Check the level of chain oil in the chain oil tank (17) before each use of the chainsaw. It is recommended to use standard chain oil.

- Position the chainsaw in a way that the chain oil tank (17) faces upwards.
- Open the cap of the chain oil tank (17) and check the oil level. If the oil level is more than 1-2 cm below the screw thread, please fill the chain oil tank (17).
- Do not overfill and leave approximately 5 mm space between the top of the oil and the inside edge of the chain oil tank (17) to allow for expansion.
- Tighten the cap of the chain oil tank (17) firmly.

## 2) Filling/Checking the fuel (Fig. 11)

### CAUTION

Always switch off the engine before fueling. Never add fuel to a machine with a running or hot engine. Only add fuel outdoors. If the engine is hot, allow to cool for at least five minutes before adding fuel. Move at least 3 m from refueling site before starting the engine. Do not smoke and stay away from open flames and sparks. Failure to follow these instructions could result in a fire and cause serious personal injury.

- a) Position the unit in a way that the fuel tank (10) faces upwards.
- b) Remove the fuel tank cap
- c) Refill with unleaded fuel carefully without overfilling. Leave approx. 5 mm space between the top of the fuel and the inside edge of the tank to allow for expansion.
- d) Tighten the fuel tank cap firmly.
- e) Wipe up any spilled fuel.

### NOTICE

It is normal for the engine to emit smoke during and after the first use. If the cutting attachment still rotates in idle speed, contact Authorized Service Centers for correct idle speed adjustment.

### NOTICE

When the engine is idling the cutting attachment must not rotate under any circumstances!

## 6.3

## OPERATION

Please note that the statutory regulations governing noise abatement may differ from one location to another.

### a) Each time before use, check the following:

- That there are no leaks in the fuel system.
- That the equipment is in perfect condition and that the safety devices and cutting devices are complete.
- That all screws are securely fastened.
- That all moving parts move smoothly.

### b) Starting the engine when cold (Fig. 12 / 13)

- Activate the chain brake lever (3) before starting.
- Switch the stop switch (14) to 'I' (ON).
- Pull the choke (9) fully out until it locks.
- Push the fuel pump 'primer bubble' (8) 6-8 times.
- Place the chainsaw on a firm, flat surface. Hold the chainsaw firmly as shown. Pull the starter handle (16) rapidly 2 times. Beware of moving chain!
- Push in the choke (9) as far as it will go.
- Hold the saw firmly and pull the starter handle (16) rapidly 4 times. Engine should start.

### CAUTION

Never allow the starter handle (16) to snap back when it has been pulled out. This may result in damage.

### CAUTION

Always pull the starter handle (16) slowly (until you feel the initial resistance) before pulling it quickly to start the engine.

Do not allow the starter handle (16) to whip back of its own accord.

If the engine does not start up even after several attempts, read the section 'Troubleshooting'.

Always pull out the starter handle (16) in a straight line. If it is pulled out at an angle, friction will occur on the eyelet.

As a result of this friction, the starter handle (16) will become frayed and will wear away faster. Always hold the starter handle (16) when the starter line retracts.

### c) Starting the engine when warm (Fig. 12 / 13)

(The equipment has been idle for less than 15-20min)

- Activate the chain brake lever (3) before starting.
- Set the chainsaw down on a firm level flat surface. Hold the saw firmly as shown. Beware of moving chain!
- Pull the starter handle (16) rapidly 4 times. The engine should start. If the chainsaw does not start after 4 tugs, repeat the steps of the procedure for starting the engine from cold.

Each time before use, check the following:

- That there are no leaks in the fuel system.

### d) Switching off the engine (Fig. 12)

Emergency Stop procedure:

To stop the engine in an emergency, activate the chain brake lever / front hand guard (3). This will immediately stop the chain. Then push the stop switch (14).

### e) Normal procedure:

Let go of the throttle lever (7) and wait until the engine has changed to idling speed. Then set the stop switch (14) to '0' Stop.

Practice all the work steps with the engine switched off before you start to use the chainsaw.

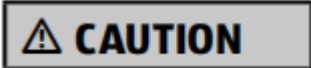

When idling, the saw chain (2) should not move. If the saw chain (2) moves, you need to adjust the idling speed!

## 6.4 OPERATING INSTRUCTIONS

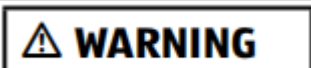

### a) Beware of the following:

- Rotary recoil (Fig. 14)  
A = Recoil distance / B = Recoil reaction zone
- Impact/Jamming recoil and pulling reactions (Fig. 15)  
A = Pull / B = Solid objects / C = Push
- To prevent pulling reactions, place the wood you wish to cut against the spiked bumper (12). Use the spiked bumper as a pivot point during cutting.
- Make sure that the chainsaw cannot swing through at the end of the cut due to its own weight. If it is no longer supported in the cut, hold something appropriate against it.

### b) Important notices

- Turn off the engine if the saw comes in contact with foreign objects. Check the saw and, if applicable, repair it.
- Protect the chain from dirt and sand. Even small quantities of dirt can quickly make the chain blunt and increase the risk of kickback.
- Start by cutting up smaller logs to practise in order to get a feel for the device, before attempting difficult tasks.
- Activate the throttle at maximum, before starting sawing.
- Press the casing of the chainsaw against the log when starting sawing.
- Run the device at full throttle throughout the whole sawing process.
- Let the saw do the work. Only use slight downwards pressure.
- Release the throttle as soon as you have finished your work, so the motor runs idle. If you let the machine run at full throttle without load, there will be unnecessary wear and tear.
- So that you do not lose control of the device after the chain exits the wood, you should not apply any pressure to the saw towards the end of the cut.
- Turn off the device before putting it down.
- Check after starting the idle setting. The cutting blade must be stationary during idling.

### c) Felling trees - only with relevant training

## CAUTION

Watch out for broken or dead branches which may fall during sawing and which could cause severe injuries. Do not saw close to buildings or power lines if you do not know in which direction the felled tree will fall. Do not work at night because you can see less well, or during rain, snow and storms because the direction in which the tree will fall cannot be anticipated.

- Plan your work with the chainsaw in advance.
- The working environment around the tree should be cleared so you have secure footing.
- The machine operator should always be positioned at a higher level in the working area because the tree will probably roll or slide down after felling.

### **d) The following conditions can influence the tree 's falling direction:**

- Wind direction and speed
- Leaning of the tree - The leaning direction cannot always be recognised because of uneven or sloping ground. Determine the leaning direction of the tree using a plumb line or a level.
- Branches growing (and therefore weight) only on one side
- Surrounding trees or obstacles

**Look out for destroyed or decayed parts of the tree.** If the trunk is decayed, it can suddenly break and fall on you. Make sure there is enough space for the falling tree.

Keep a distance of 2½ tree lengths to the next person or other objects. The sound of the motor can drown out warning cries.

Remove dirt, stones, loose bark, nails, brackets and wire from the sawing area.

Ensure you have a free escape route (Fig. 16)

Position 1: Escape route

Position 2: Falling direction of the tree

### **e) Felling of large trees (from 15 cm diameter) - only with relevant training**

The undercutting method is used for felling large trees. For this, a wedge is cut out from the side of the tree according to the required falling direction. After the dropping cut has been made on the other side of the tree, it will fall in the direction of the wedge cut.

## NOTICE

If the tree has large prop/buttress roots, these should be removed before the wedge is cut. If the saw is used for removing the prop/buttress roots, the saw-chain should not touch the ground, so the chain does not become blunt.

### **f) Undercut and felling the tree (Fig. 17 / 18)**

- For the undercut, first cut the upper part (Pos. 1) of the wedge (Pos. 2). Cut 1/3 of the way into the tree. Then saw the lower part (Pos. 3) of the wedge (Pos. 2). Now remove the wedge you have cut out.
- Afterwards, you can carry out the dropping cut on the opposite side of the tree (Pos. 4). For this, start about 5 cm above the middle of the cut. In this way, there is enough wood between the dropping cut (Pos. 4) and the wedge (Pos. 2) so that it functions as a hinge. This hinge is designed to guide the tree in the right direction when falling.

## NOTICE

Before completing the dropping cut, if required, increase the cut using wedges to control the direction of the fall. Exclusively use wood or plastic wedges. Steel or iron wedges can cause kickback and damage to the device.

- Be aware of signs that the tree is beginning to fall: Cracking sounds, the dropping cut opening or movement in the upper branches.
- When the tree begins to fall, stop the saw, put it down and leave immediately via your escape route.
- To prevent injuries, do not cut partly felled trees with your saw. Beware especially of partly felled trees which are not supported. If a tree does not fall completely, remove the saw and help the process along with a cable winch, a pulley or a towing vehicle.

### **g) Sawing a felled tree (log division)**

The term "log division" describe the cutting up of a felled tree into logs of the desired length.

**⚠ CAUTION**

Do not stand on the log you are currently cutting. The log could roll away and you may lose your footing and control of the device. Do not carry out sawing work on sloping ground.

**h) Important notices**

- Only ever saw one log or branch.
- Be careful when cutting split wood. You may be hit by sharp pieces of wood.
- Cut small logs or branches on a sawhorse. When cutting logs, no other person must hold on to the log. Do not secure the log with your leg or foot.
- Do not use the saw in areas where logs, roots and other parts of the tree are entangled. Pull the logs to a free area and cut the freed logs first.

**i) Different cuts for log division (Fig. 19)****⚠ CAUTION**

If the saw is jammed in a log, do not pull it out with force. You may lose control of the device and suffer severe injuries and/or damage the saw.

Stop the saw and drive a plastic or wooden wedge into the cut until the saw can be pulled out easily. Restart the saw and carefully continue with the cut. Never start the saw when it is jammed in a log.

**j) Topping (Fig. 20, Pos. 1)**

Topping starts at the upper side of the log where you hold the saw against the log. Only use slight downwards pressure for topping.

**k) Undercut (Fig. 20, Pos. 2)**

Start the undercut on the underside of the log and hold the top edge of the saw against the log. Only use slight upwards pressure for the undercut. Hold the saw securely to control the device. The saw will push backwards (in your direction).

**⚠ CAUTION**

Never hold the saw the wrong way around for an undercut. You do not have control of the device in this position. Always make the first cut on the compression side of the log. The compression side of the log is where the pressure of the log 's weight is concentrated.

**l) Log division without supports (Fig. 21)**

- Using topping (Pos. 1), saw 1/3 of the way into the log.
- Turn the log around and make a second top cut (Pos. 2).
- When sawing on the compression side, make sure the saw does not get jammed. See Figure for cuts in logs on the compression side.

**m) Log division with log or support (Fig. 22-23)**

- Always remember to make the first cut (Pos. 1) on the loaded side of the log.
- Cut 1/3 into the log for this.
- Make a second cut (Pos. 2).

**n) Trimming and pruning****⚠ CAUTION**

Always be careful and protect yourself from kickback. Never let the moving chain at the tip of the chain guide come in contact with other branches or objects during trimming or cutting branches. Such contact can lead to serious injuries.

**⚠ CAUTION**

Never climb into the tree for trimming or pruning. Do not stand on ladders, platforms etc. You could lose your balance and control of the device.

## o) Important notices

- Work slowly and hold on to the saw with both hands. Ensure a secure standing position and balance.
- Beware of recoiling parts of the tree. Practise extreme caution when cutting small parts of the tree. Flexible material can get caught in the saw-chain and be ejected in your direction or make you lose your balance.
- Beware of recoiling parts of the tree. This particularly applies to bent or loaded branches. Avoid coming in contact with the branch or the saw when the tension on the wood is released.
- Keep your working area clear. Clear the path of branches so you do not trip over them.

## p) Trimming

- Do not start trimming the tree before it has been felled. Only then can you carry out the trimming safely and properly.
- Leave larger branches underneath the felled tree and use them as a support while you continue working.
- Start at the foot of the felled tree and work your way up to the top. Remove smaller parts of the tree with one cut.
- Make sure that the tree is always between you and the saw.
- Remove larger, supporting branches using the method from section “Log division without supports “.
- Always remove small freely suspended parts of the tree with a top cut. They may fall into the saw or trap it if you use an undercut.

## q) Pruning (Fig. 24)



Prune branches only at or below shoulder height. Never cut branches above shoulder height. Leave that kind of work to a professional.

- For the first cut (Pos. 1), cut 1/3 of the way into the lower part of the branch.
- Then cut all the way through the branch with the second cut (Pos. 2). The third cut (Pos. 3) is a top cut with which you separate the branch from the trunk at 2.5 to 5 cm.

# 7. CLEANING MAINTENANCE AND SERVICING

## 7.1 CLEANING

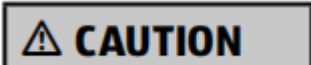

**Push the stop switch (Fig.1 / pos. 14) before doing any cleaning and maintenance work!**

Carrying out any cleaning work

- The equipment should be cleaned thoroughly every time after it has been used. This applies particularly to the chain and bar.
- Keep the air vents and the motor housing free of dirt and dust as far as possible. Wipe the equipment with a clean damp cloth or blow it down with compressed air at low pressure.
- It is easiest to remove sawdust and wood chippings immediately after use.
- Clean the equipment regularly with a damp cloth and some soft soap. Do not use cleaning agents or solvents; these may be aggressive to the plastic parts in the equipment. Ensure that no water can get into the interior of the equipment.



## 7.2 MAINTENANCE AND SERVICING

### a) MAINTENANCE

#### CAUTION

All maintenance work on the chainsaw apart from the work described in this manual may only be carried out by authorised after-sales service personnel.

#### **Chain brake operational test**

Test the chain brake periodically to ensure proper function. Perform a chain brake test prior to initial cutting, following extensive cutting.

#### **Chain brake service.**

Test chain brake as follows:

- Place saw on a clear, firm, flat surface.
- Start the engine.
- Grasp the rear handle with your right hand.
- With your left hand, hold the front handle (Fig. 1/pos. 4) (not chain brake lever / front hand guard / pos. 3) firmly.
- Squeeze the throttle lever (Fig. 1/pos. 7), then immediately activate the chain brake lever (Fig. 1/pos. 3).

#### CAUTION

Activate the chain brake slowly and deliberately. Keep the saw chain from touching anything, don't let the saw tip forward.

- The saw chain should stop abruptly. When it does, immediately release the throttle lever.

#### CAUTION

If the saw chain does not stop, turn engine off and take your unit to the nearest Authorized Service Centre for service.

- If the chain brake functions properly, turn the engine off and return the chain brake to the DISENGAGED position.

#### **Air Filter (Fig. 25)**

#### NOTICE

Never operate the chainsaw without the air filter. Dust and dirt will be drawn into the engine and damage it. Keep the air filter clean! The air filter must be cleaned or replaced after every 20 hours of service.

#### **Cleaning the air filter**

- Remove the air filter cover (G) by removing the clip.
- Open the air filter flap (H).
- Lift out the air filter
- Clean the air filter. Wash the filter in clean, warm, soapy water. Rinse in clear, cool water. Air dry completely before refitting. It is advisable to have a supply of spare filters.
- Insert the air filter.

#### **Spark plug (Fig. 26 / 27)**

To ensure that the saw's engine retains its power, the spark plug must be clean and have the correct electrode gap (0.6-0.7 mm). The spark plug must be cleaned or replaced after every 20 hours of service.

- Disconnect the spark plug boot (I) from the spark plug by pulling and twisting it simultaneously.
- Remove the spark plug using the supplied spark plug spanner (19). DO NOT USE ANY OTHER TOOLS.
- Clean the spark plug with a copper wire brush and refit it or fit a new spark plug.

#### **Carburettor and idling speed settings**

Settings on the carburettor may only be made by authorised customer service personnel.

#### **Chain bar maintenance (Fig. 28)**

Regular lubrication of the chain bar (guide rail for the chain and teeth) is essential.



The chain bar needs the maintenance described in the following section for the saw to work at an optimum level of performance.

**⚠ NOTICE**

The sprocket tip on your new saw has been pre-lubricated at the factory. Failure to lubricate the guide bar sprocket tip as explained below will result in poor performance and seizure, voiding the manufacturer's warranty.

**To lubricate the sprocket tip**

If the saw is used intensively it will be necessary to lubricate the guide bar sprocket tip (J) regularly (once a week).

To do this, first thoroughly clean the 2 mm hole (K) at the tip of the guide bar, and then press in a small amount of multi-purpose grease.

Multi-purpose grease and grease guns are available in specialty retail trade.

**⚠ NOTICE**

The saw chain does not have to be removed in order to lubricate the sprocket tip of the chain bar. Lubrication is possible during work, with the engine switched off.

**⚠ CAUTION**

Wear heavy duty work gloves when handling the bar and chain.

Most guide bar problems can be prevented merely by keeping the chainsaw well maintained. Insufficient guide bar lubrication and operating the saw with a chain that is TOO TIGHT will contribute to rapid bar wear. To help minimize bar wear, the following guide bar maintenance procedures are recommended.

**⚠ CAUTION**

Always wear protective gloves during maintenance operations.

Do not carry out maintenance when the engine is hot.

**Chain sharpening**

Chain sharpening requires special tools to ensure that cutters are sharpened at the correct angle and depth. For the inexperienced chainsaw user, we recommend that the saw chain be professionally sharpened by the nearest professional Service Centre. If you feel comfortable sharpening your own saw chain, special tools are available from the professional Service Centre.

Sharpen the chain using protective gloves. After sharpening, the cutting links must all have the same width and length.





Cutting links with different width and length can cause a kickback.

**⚠ NOTICE**

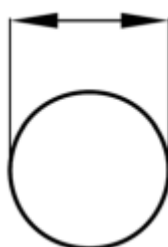
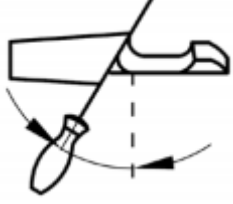
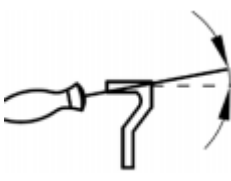
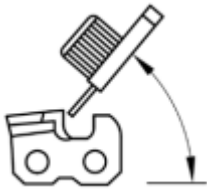
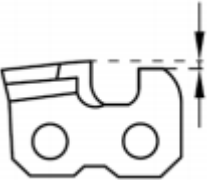
A sharp chain produces well-defined chips. When your chain starts to produce sawdust, it is time to sharpen. After the blades have been sharpened 3-4 times, check the height of the depth limiter and if necessary lower it with a flat file and then round off the front corner.

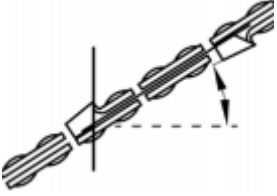
Instructions for sharpening a saw chain:

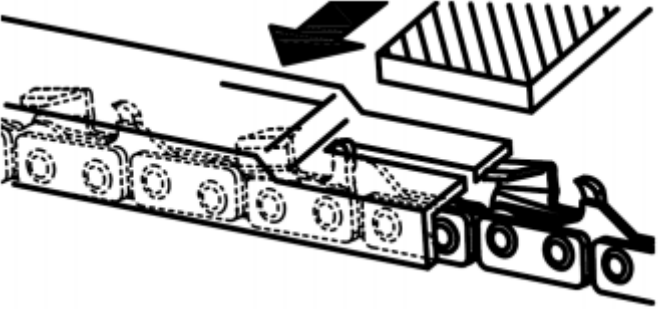
	File diameter (not included)	Upper angle	Lower angle	Upper tilt angle (55°)	Standard depth
Chainsaw type					
		Chucking rotation angle	Chucking inclination angle	side angle	

					
91P	ca. 4.0 mm	30°	0°	80°	0.64 mm
					
depth stop			file		

### Chain tension

Check the chain tension frequently and adjust as often as necessary to keep the chain snug on the bar, but loose enough to be pulled around by hand.

### Oil passages

Oil passages on the bar should be cleaned to ensure proper lubrication of the bar and chain during operation.

#### NOTICE

The condition of the oil passages can be easily checked. If the passages are clear, the chain will automatically give off a spray of oil within seconds of starting the saw. Your saw is equipped with an automatic oiler system.

### Automatic chain lubrication

The chainsaw is equipped with an automatic oil lubrication system with a toothed wheel drive. It automatically supplies the bar and the chain with the right quantity of oil. The moment the engine is accelerated, the oil also starts to flow through the bar plate more quickly as well.

The chain lubrication system has been set to its perfect adjustment at the factory.

To check the chain lubrication, hold the chainsaw, with the chain, over a piece of paper and run it at full speed for a few seconds. You will be able to judge the set amount of oil from the paper.

If it requires adjusting, take the saw to your nearest authorised after-sales service outlet.

## 8. STORAGE & TRANSPORT

### 8.1 STORAGE

#### CAUTION

Never put the equipment into storage for longer than 30 days without carrying out the following steps.

Store the equipment in a secure, dry, frost-free and well-ventilated location that is protected from the effects of weather.

Outside storage is not recommended. Secure it against unauthorised access.

If you intend to store the equipment for longer than 30 days, it must be prepared accordingly. Otherwise the fuel remaining in the carburetor will evaporate and leave a rubbery sediment. This can cause problems when starting up the equipment and may require expensive repairs.

- Slowly remove the fuel tank cap to release any pressure that may have formed in the tank. Carefully empty the tank of fuel.
- To remove the fuel from the carburetor, start the engine and let it run until the equipment stops.
- Leave the engine to cool (approx. 5 minutes).

## 8.2 TRANSPORT

Clean coarse dirt off the equipment with a brush or hand brush. Always mount the chain guard (20) to the chain bar (1).

## 9. DISPOSAL AND RECYCLING

The equipment is supplied in packaging to prevent it from being damaged in transit.

The raw materials in this packaging can be reused or recycled. The equipment and its accessories are made of various types of material, such as metal and plastic. Never place defective equipment in your household refuse. The equipment should be taken to a suitable collection center for proper disposal. If you do not know the whereabouts of such a collection point, you should ask in your local council offices.

## 10. TROUBLESHOOTING

The table below contains a list of fault symptoms and explains what you can do to remedy the problem if your equipment fails to work properly. If the problem persists after working through the list, please contact your nearest service workshop.

### IMPORTANT!

Hint in case of sending the equipment to a service centre:

Due to safety reasons please see to it that the equipment is sent back free of oil and petrol.

Problem	Probable cause	Corrective Action
Unit won't start or starts but will not run.	Incorrect starting procedures.	Follow instructions in the User Manual.
	Incorrect carburettor mixture adjustment setting.	Have carburettor adjusted by an Authorized Service Center.
	Fouled spark plug.	Clean / gap or replace plug.
	Fuel filter plugged.	Replace fuel filter.
Engine hesitates.	Incorrect carburettor mixture adjustment setting.	Have carburettor adjusted by an Authorized Service Center.
No power under load.	Incorrectly gapped spark plug.	Clean / gap or replace plug.
Runs in the wrong way	Incorrect carburetor mixture adjustment setting.	Have carburettor adjusted by an Authorized Service Center.
Poor performance when operated	Blunt chain. Loose chain.	Sharpen or replace the chain. Tension the chain.
Engine dies	Empty petrol tank. Fuel filter in the wrong position in the tank.	Fill up the petrol tank. Completely fill the petrol tank or re-position the fuel filter in the petrol tank.
Insufficient chain lubrication (the cutter rail and chain get hot)	Empty oil tank for the chain.	Top up the oil tank for the chain.
	Oil lubrication openings moved.	Clean the oil lubrication hole in the cutter bar. Clean the groove in the cutter bar.

# 11. DECLARATION OF CONFORMITY



BUILDER

ZI, 32 rue Aristide Bergès – 31270 Cugnaux - France

Declares that the machinery designated below:

PETROL CHAIN SAW

Model RAC49CS4T

Serial number: 20211154690- 20211155189

Complies with the provisions of the Directive "machinery" 2006/42/EC and regulations

National transposing it;

Also complies with the following European directives:

EMC Directive 2014/30/EU

RoHS Directive (EU)2015/863 amending 2011/65/EU

Emission directive (EU) 2016/1628 & 2017/656/EU

Noise emission Directive 2000/14/EC Annex V and Directive 2005/88/EC

Guarantee sound power level: 110 dB(A)

Measured sound power level: 109.09 dB(A) K=0.61 dB(A)

Also complies with European standards, national standards and provisions following techniques:

EN ISO 11681-2: 2011+A1: 2017

EN ISO 14982: 2009

EC-type certificate number: BM 50467311 0001 Notified body No.0197 TUV Rheinland

Responsible of the technical file: Mr Patriarca

Cugnaux, le 20/08/2021

Philippe MARIE / PDG

## 12. WARRANTY

The manufacturer guarantees the product against defects in material and workmanship for a period of 2 years from the date of the original purchase. The warranty only applies if the product is for household use. The warranty does not cover breakdowns due to normal wear and tear.

The manufacturer agrees to replace parts identified as defective by the designated distributor. The manufacturer does not accept responsibility for the replacement of the machine, in whole or in part, and/or ensuing damage.

**The warranty does not cover breakdowns due to:**

- insufficient maintenance.
- abnormal assembly, adjustment or operations of the product.
- parts subject to normal wear and tear.

**The warranty does not extend to:**

- shipping and packaging costs.
- using the tool for a purpose other than that for which it was designed.
- the use and maintenance of the machine done in a manner not described in the user manual.

Due to our policy of continuous product improvement, we reserve the right to alter or change specifications without notice. Consequently, the product may be different from the information contained therein, but a modification will be undertaken without notice if it is recognized as an improvement of the preceding characteristic.

### **READ THE MANUAL CAREFULLY BEFORE USING THE MACHINE.**

When ordering spare parts, please indicate the part number or code, you can find this in the spare parts list in this manual. Keep the purchase receipt; without it, the warranty is invalid. To help you with your product, we invite you to contact us by phone or via our website:

- **+33 (0)9.70.75.30.30**
- **<https://services.swap-europe.com/contact>**

You must create a "ticket" via the web platform.

- Register or create your account.
- Indicate the reference of the tool.
- Choose the subject of your request.
- Describe your problem.
- Attach these files: invoice or sales receipt, photo of the identification plate (serial number), photo of the part you need (for example: pins on the transformer plug which are broken).



# 13. PRODUCT FAILURE

## WHAT TO DO IF MY MACHINE BREAKS DOWN?

### If you bought your product in a store:

- a) Empty the fuel tank if your product has one.
- b) Make sure that your machine is complete with all accessories supplied, and clean! If this is not the case, the repairer will refuse the machine.

Go to the store with the complete machine and with the receipt or invoice.

### If you bought your product on a website:

- a) Empty the fuel tank if your product has one.
- b) Make sure that your machine is complete with all accessories supplied, and clean! If this is not the case, the repairer will refuse the machine.
- c) Create a SWAP-Europe service ticket on the site: <https://services.swap-europe.com> When making the request on SWAP-Europe, you must attach the invoice and the photo of the nameplate (serial number).
- d) Contact the repair station to make sure it is available before dropping off the machine.

Go to the repair station with the complete machine packed, accompanied by the purchase invoice and the station support sheet downloadable after the service request is completed on the SWAP-Europe site

For machines with engine failure from manufacturers BRIGGS & STRATTON, HONDA and RATO, please refer to the following instructions.

Repairs will be done by approved engine manufacturers of these manufacturers, see their site:

- <http://www.briggsandstratton.com/eu/fr>
- <http://www.honda-engines-eu.com/fr/service-network-page;jsessionid=5EE8456CF39CD572AA2AEEDFD290CDAE>
- <https://www.rato-europe.com/it/service-network>

**Please keep your original packaging to allow for after-sales service returns or pack your machine with a similar cardboard box of the same dimensions.**

**For any question concerning our after-sales service you can make a request on our website [https:// services.swap-europe.com](https://services.swap-europe.com)**

**Our hotline remains available at +33 (9) 70 75 30 30.**



# 14. WARRANTY EXCLUSIONS

## THE WARRANTY DOES NOT COVER:

- Start-up and setting up of the product.
- Damage resulting from normal wear and tear of the product.
- Damage resulting from improper use of the product.
- Damage resulting from assembly or start-up not in accordance with the user manual.
- Breakdowns related to carburetion beyond 90 days and fouling of carburetors.
- Periodic and standard maintenance events.
- Actions of modification and dismantling that directly void the warranty.
- Products whose original authentication marking (brand, serial number) has been degraded, altered or withdrawn.
- Replacement of consumables.
- The use of non-original parts.
- Breakage of parts following impacts or projections.
- Accessories breakdowns.
- Defects and their consequences linked to any external cause.
- Loss of components and loss due to insufficient screwing.
- Cutting components and any damage related to the loosening of parts.
- Overload or overheating.
- Poor power supply quality: faulty voltage, voltage error, etc.
- Damages resulting from the deprivation of enjoyment of the product during the time necessary for repairs and more generally the costs related to the immobilization of the product. The costs of a second opinion established by a third party following an estimate by a SWAP-Europe repair station
- The use of a product which would show a defect or a breakage which was not the subject of an immediate report and/or repair with the services of SWAP-Europe.
- Deterioration linked to transport and storage\*.
- Launchers beyond 90 days.
- Oil, petrol, grease.
- Damages related to the use of non-compliant fuels or lubricants.

\* In accordance with transport legislation, damage related to transport must be declared to carriers within 48 hours maximum after observation by registered letter with acknowledgement of receipt. This document is a supplement to your notice, a non-exhaustive list.

**Attention:** all orders must be checked in the presence of the delivery person. In case of refusal by the delivery person, it you must simply refuse the delivery and notify your refusal.

**Reminder:** the reserves do not exclude the notification by registered letter with acknowledgement within 72 hours.

### Information:

Thermal devices must be wintered each season (service available on the SWAP-Europe site). Batteries must be charged before being stored.









BUILDER SAS

32 rue Aristide Berges - Z.I. du Casque - 31270 Cugnaux - France.

MADE IN PRC 2021