

HYUNDAI
POWER PRODUCTS

CORDLESS LAWNMOWER

HTDEN4640VT

ORIGINAL INSTRUCTIONS

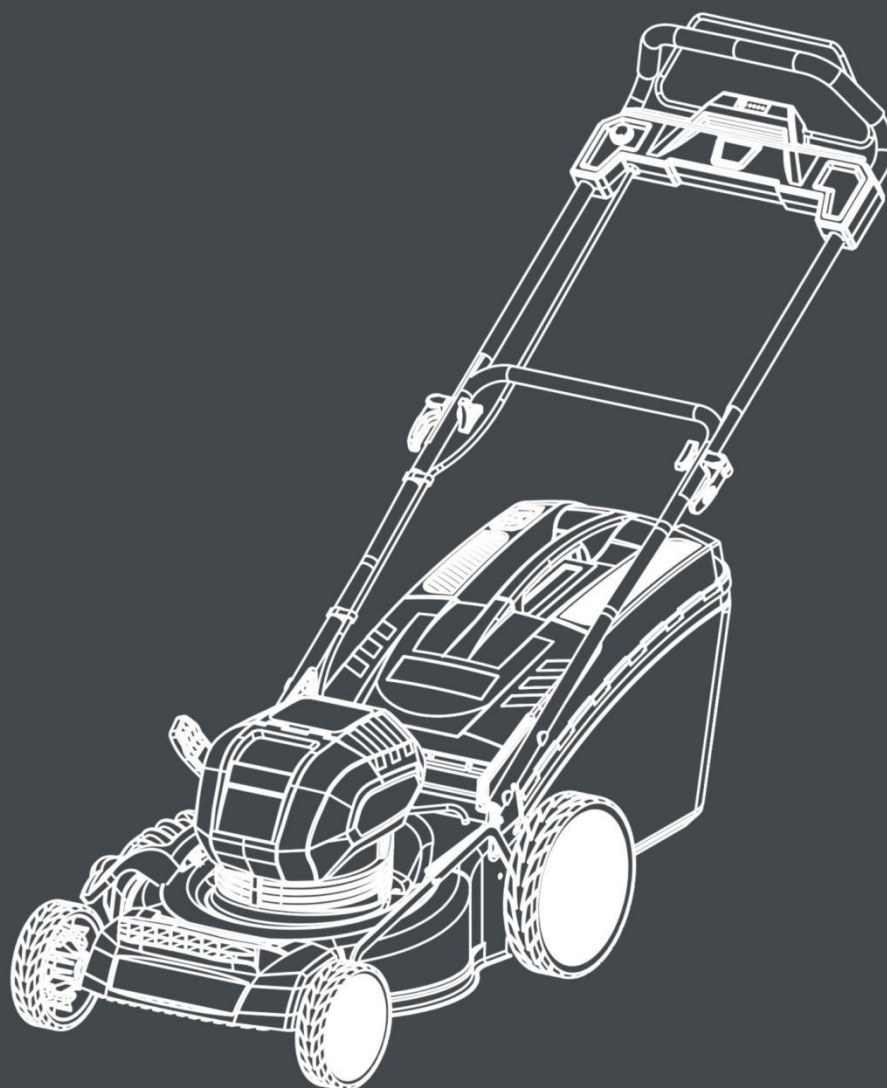

READ THE INSTRUCTIONS BEFORE USE THIS TOOL!

1.SAFETY WARNING

IMPORTANT READ CAREFULLY BEFORE US KEEP FOR FUTURE REFERENCE

- 1) Read the instructions carefully. Be familiar with the controls and the proper use of the equipment;
- 2) Never allow children or people unfamiliar with these instructions to use the lawnmower. Local regulations can restrict the age of the operator
- 3) Never mow while people, especially children, or pets are nearby;
- 4) Keep in mind that the operator or user is responsible for accidents or hazards occurring to other people or their property.
- 5) While mowing, always wear substantial footwear and long trousers. Do not operate the equipment when barefoot or wearing open sandals; Avoid wearing clothing that is loose fitting or that has hanging cords or ties.
- 6) Thoroughly inspect the area where the equipment is to be used and remove all objects which can be thrown by the machine.
- 7) Before using, always visually inspect to see that the blades, blade bolts and cutter assembly are not worn or damaged. Replace worn or damaged blades and bolts in sets to preserve balance. Replace damaged or unreadable labels.
- 8) mow only in daylight or in good artificial light;

- 9) avoid operating the equipment in wet grass, where feasible;
- 10) Always be sure of your footing on slopes;
- 11) Walk, never run;
- 12) For wheeled rotary machines; mow across the face of slopes, never up and down;
- 13) exercise extreme caution when changing direction on slopes;
- 14) Do not mow excessively steep slopes;
- 15) Use extreme caution when reversing or pulling the lawnmower towards you;
- 16) Stop the blades if the lawn mower has to be tilted for transportation when crossing surfaces other than grass, and when transporting the lawn mower to and from the area to be mowed;
- 17) Never operate the lawnmower with defective guards, or without safety devices, for example deflectors and/or grass catchers, in place
- 18) Start or switch on the motor carefully according to instructions and with feet well away from the blades;
- 19) Do not tilt the lawnmower when starting switching on the motor, except if the lawnmower has to be tilted for starting. In this case, do not tile it more than absolutely necessary and lift only the part which is away from the operator;
- 20) Do not start the motor when standing in front of the discharge chute;
- 21) Do not put hands or feet near or under rotating parts, Keep clear of the discharge opening at all times
- 22) Never pick up or carry a lawnmower while the motor is running;

23) Stop the motor and switch off isolator key. Make sure that all moving parts have come to a complete stop

- Whenever you leave the machine
- Before clearing blockages or unclogging chute
- Before checking, cleaning or working on the lawnmower;
- After striking a foreign object. Inspect the lawnmower for damage and make repairs before restarting and operating the lawnmower;

24) If lawnmower starts to vibrate abnormally (check immediately);

- Inspect for damage;
- Replace or repair any damage parts.
- Check for and tighten any loose parts.

25) Stop the mower:

- whenever you leave the lawnmower;

26) keep all nuts, bolts and screws tight to be sure the equipment is in safe working condition;

27) Check the grass catcher frequently for wear or deterioration;

28) Replace worn or damaged parts for safety;

29) Children are not allowed to use the machine.

30) This appliance is not intended for use by persons with reduced physical, sensory or mental capabilities, or lack of experience and knowledge, unless they have been given supervision or instruction concerning use of the appliance by a person responsible for their safety.

31) Be careful during adjustment of the machine to prevent entrapment of the fingers between moving

blades and fixed parts of the machine.

32) Always allow the machine to cool before storing.

33) After use and before storage, remove the battery from the machine and check for damage.

34) When servicing the blades be aware that, even though the power source is switched off, the blades can still be moved.

35) Replace worn or damaged parts for safety; Use only genuine replacement parts and accessories.

36) Be careful during adjustment of the appliance to prevent entrapment of the fingers between moving blades and fixed parts of appliance.

37) Recharge only with the charger specified by the manufacture .Using a charge with an incompatible battery pack may create a risk of fire.

38) Use power tools only with specifically designated battery packs .Use of any other battery packs may create a risk of injury and fire.

39) When battery pack is not in use, keep it away from other metal objects like, paper clips, coin, keys, nails, screws, or other small metal objects, that can make a connection from one terminal to another. Shorting the battery terminals together may cause burns or a fire.

40) Under abusive conditions, liquid may be ejected from the battery:

- If contact accidentally occurs, flush with water.
- If liquid contacts eyes additionally seek medical help. Liquid ejected from the battery may cause irritation or burns.

41) When device is not in use, keep it away from other metal objects like paper clips, coins, keys, nails,

screws, or other small metal objects that can make a connection from one terminal to another. Shorting the battery terminals together may cause burns or a fire.

42) Under abusive conditions, liquid may be ejected from the battery, avoid contact. If contact accidentally occurs, flush with water. If liquid contacts eyes, additionally seek medical help. Liquid ejected from the battery may cause skin irritation or burns.

43) Children shall not play with the appliance.

44) Cleaning and user maintenance shall not be made by children.

Safety advice for rechargeable battery and charger

- Use only the battery provided with the lawn mower and the provided charger.
- Protect battery and battery charger from humidity.
- Do not operate the battery charger outdoors.
- When it is not in use or before cleaning and servicing, disconnect the battery charger from the power supply.
- Take special care of the battery. Avoid dropping it onto any hard surface and do not subject it to pressure or any other form of mechanical stress.
- Keep the battery away from extreme heat and cold.
- Do not open or attempt to repair the battery or the battery charger. If any parts are defective, have them repaired by a qualified technician or send them to our service department for repair.
- Only charge and use the battery at an ambient (surrounding air) temperature between 0°C and +50°C.
- When not in use, store the battery in a dry place between 10°C and 30°C.

- The battery should be recharged when it fails to produce sufficient power on jobs which were easily done previously. DO NOT CONTINUE using product with its battery in a depleted condition.
- The battery is not fully charged at the factory. Before attempting to use it, it must be fully charged firstly.

WARNING:

Never short-circuit the battery or expose it to moisture. Do not store it together with any metal parts which could short-circuit the contacts. The battery could overheat, start burning or explode.

If any person comes into contact with acid or similar internal fluids or substances contained in the battery, wash off these substances immediately with plenty of water. If these substances make contact with the eyes, rinse with plenty of water and visit a doctor immediately. Do not place the rechargeable battery into fire or water. It can explode. The Rechargeable Battery should not be discarded to domestic refuse, regardless of whether used or unused. You should return it to a local battery collection point in accordance with Battery Regulations or return them to us suitably marked "Used Battery".

CHILD SAFETY

Tragic accidents can occur if the operator is not aware of the presence of children.

- Keep children out of the mowing area and under the watchful care of a responsible adult.
- Do not allow children under the age of 14 to operate this mower. Children who are 14 years of age and

older must read and understand the operating instructions and safety rules in this manual, and must be trained and supervised by a parent.

- Stay alert, and turn the mower off if a child or any other person enters the mowing area.
- Look behind and down for small children before and while moving backwards.
- Use extreme care when approaching blind corners, doorways, shrubs, trees, or other objects that may obscure your view of a child who may run into the path of the mower.

Symbols



Read this instruction book carefully before using the lawn mower and keep it in a safe place for future reference



Risk of projections. Keep bystanders away.



Beware of sharp blades. Blades continue to rotate after the motor is switched off. Remove disabling device before maintenance



Guarantee noise level

Intended use

This mower is designed for natural grass mowing. Any other use is prohibited. It is suitable only for private use in a garden or plot. Lawnmowers designed for private plots or gardens are those used for the maintenance of grassy areas and private lawns and should not be used in public areas, parks, sports, agricultural or forest areas.

2. THE PRODUCT

a. Product description

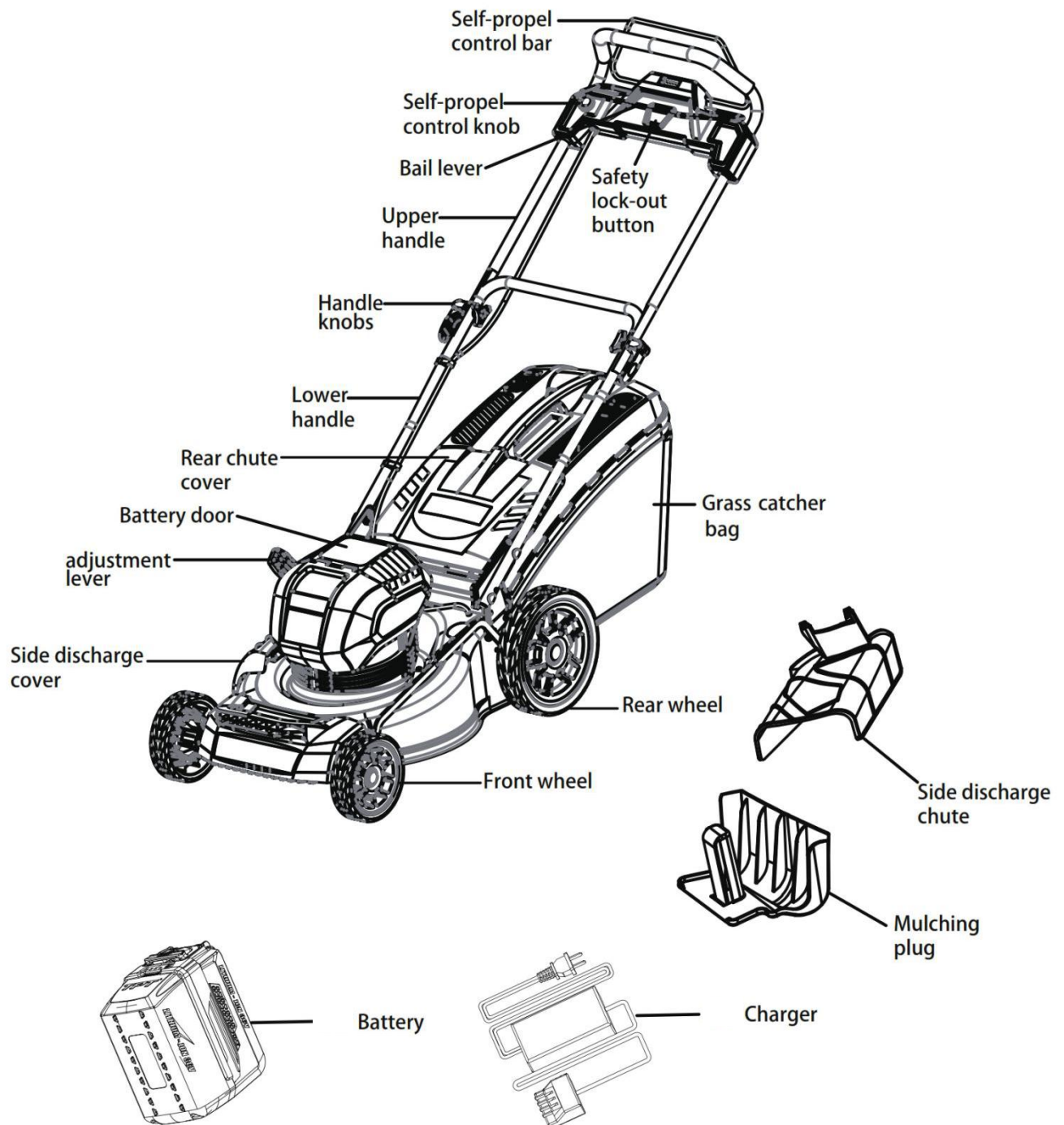

This lawnmower is provided **without** battery and battery charger. Please buy a battery pack (battery + charger) from the same trademark of this tool. The recommended product is: HYUNDAI 40V LITHIUM ION BATTERY CHARGER. Do not use non recommended battery.

b. Technical data

Model	HTDEN4640VT
Voltage	40V d.c.
No load speed	2300-3300/min
Cutting width	460 mm
Cutting height	35-90mm (6 positions)
Volume of grass catcher	60 L
Net weight	22 kg
Guarantee sound power level	94 dB(A)
Sound power level	90 dB(A) K= 3 dB(A)
Sound pressure level	75 dB(A) K= 3 dB(A)
Vibration	2,2 m/s ² K= 1,5m/s ²

3. ASSEMBLY

a. Unpacking

Before beginning assembly of product, make sure all parts are present. Compare parts with package contents list and hardware contents list. If any part is missing or damaged, do not attempt to assemble the product.

- Carefully remove the product and any accessories from the box. Make sure that all items listed in the packing list are included.
- Inspect the product carefully to make sure no breakage or damage occurred during shipping.
- Do not discard the packing material until you have carefully inspected and satisfactorily operated the product.
- If any parts are damaged or missing, please call dealer for assistance.

b. UNFOLDING AND ADJUSTING LOWER HANDLE

WARNING

Folding or unfolding the handle improperly can damage the cables, causing an unsafe operating condition.

- Do not damage the cables when folding or unfolding the handle.
- If a cable is damaged, contact an Authorized Service Dealer.

To raise handle assembly(Fig.A):

- 1) Pull up and back on the lower handle (1) until it is aligned with the hole position of the arm support and the mower housing.
- 2) To secure the lower handle (1) in place, lock the lower screw (3).
- 3) Open the upper cam locks (2).
- 4) Pull up and back on the upper handle to raise it into operating position.
- 5) To secure the upper handle in place, close the upper cam locks (2).

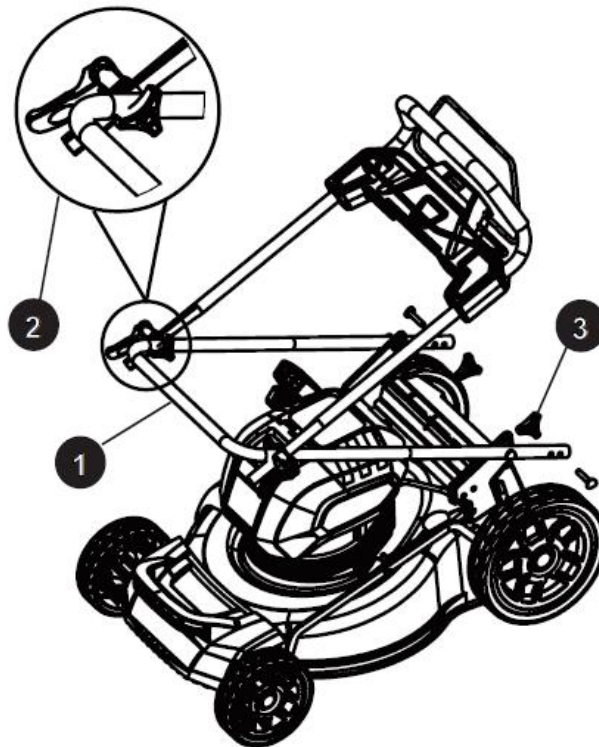

(Fig.A)

NOTE: If the upper handle is loose or separated from the lower handle, tighten the knobs on the upper handle locks by turning them clockwise.

INSTALLING THE GRASS CATCHER BAG (Fig.B):

- 1) Lift the rear discharge door (1).

- 2) Lift the grass catcher by its handle (2) and place under the rear discharge door so that the hooks (3) on the grass catcher are seated on the door rod (4).
- 3) Release the rear discharge door. When installed correctly, the hooks on the grass catcher will extend through the openings on the rear discharge door.

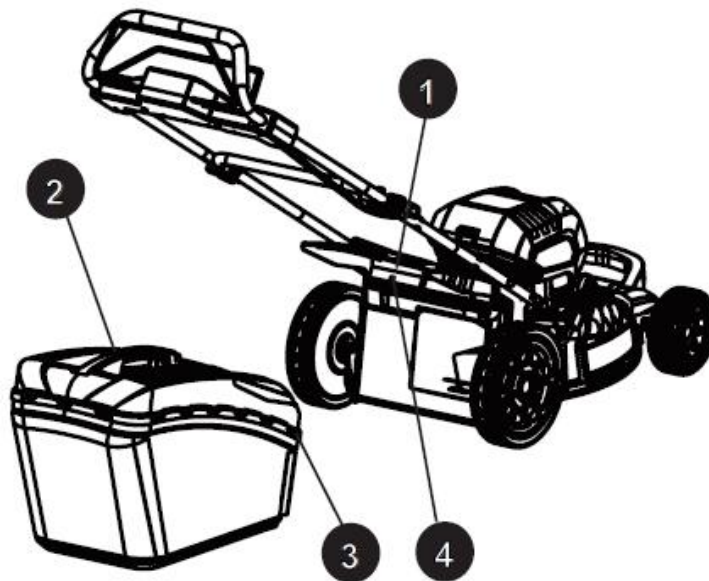

(Fig.B)

NOTE: When using the grass catcher, do not install either the side discharge chute or the mulching plug.

INSTALLING/REMOVING THE MULCHING PLUG(Fig.C):

- 1) To remove the mulching plug, lift the rear discharge door (1).
- 2) Grasp the handle (2) of the mulching plug.
- 3) Lift and pull the mulching plug out using the handle.
- 4) The mulching plug (3) is inserted at an angle, so it requires some force to remove it.
- 5) The mulching plug must be removed in order to install the grass catcher bag.
- 6) The mulching plug must be re-installed when the grass catcher bag is removed.

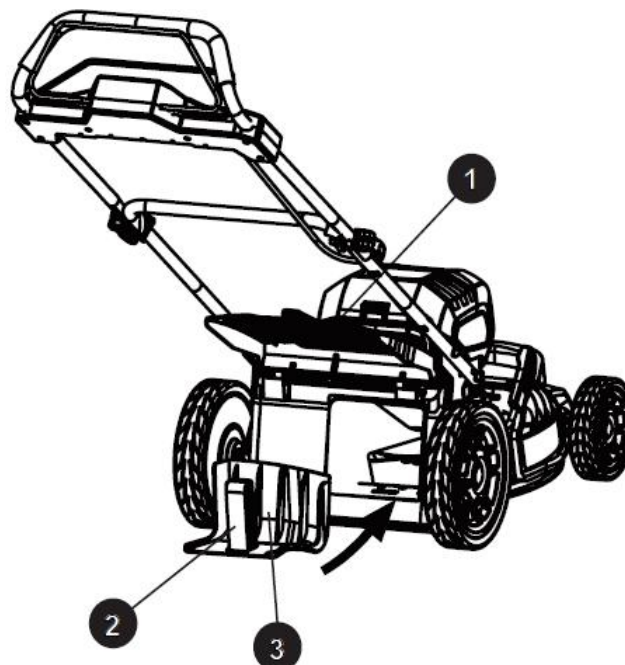

(Fig.C)

NOTE: When mulching, do not install either the side discharge chute or the grass catcher bag.

INSTALLING SIDE DISCHARGE CHUTE(Fig.D)

- 1) Lift the side discharge cover (1).
- 2) Align the grooves (2) on the discharge chute (3) with the pins (4) on the underside of the discharge cover (1).
- 3) Lower the discharge chute until the hooks on the mower deck are secured in the openings in the

discharge chute.

- 4) Release the side discharge cover.

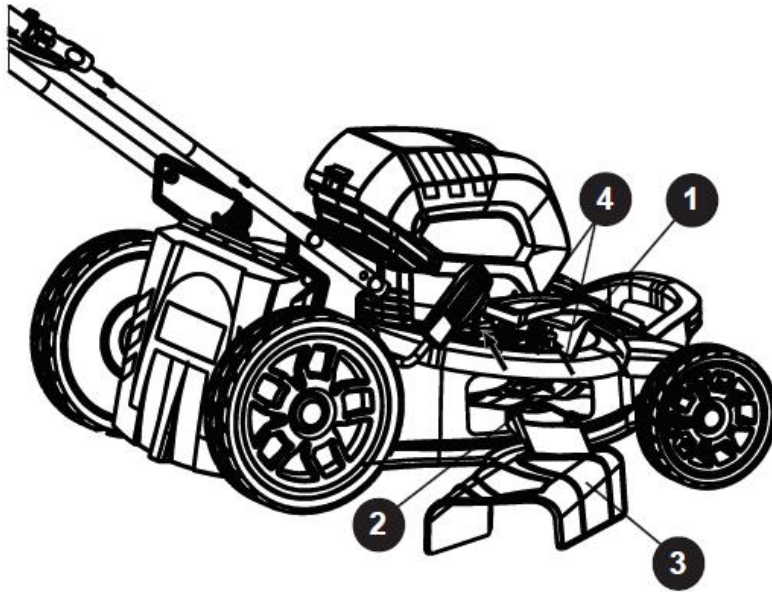

(Fig.D)

NOTE: When using side discharge, do not install the the grass catcher bag. Ensure the mulch plug is installed.

TO INSTALL BATTERY PACK(Fig.E):

- 1) Lift and hold up the battery door (1).
- 2) Align the battery (2) with the mower' s battery port.
- 3) Make sure the battery release button (3) snaps in place and that battery is fully seated and secure in the mower before beginning operation.
- 4) If the machine is not going to be used immediately, remove the battery.

TO REMOVE BATTERY PACK(Fig.E):

- 1) Release the bail lever to stop the mower.
- 2) Press the battery release button (3) on the mower. Open the battery door.
- 3) Remove battery from the mower.

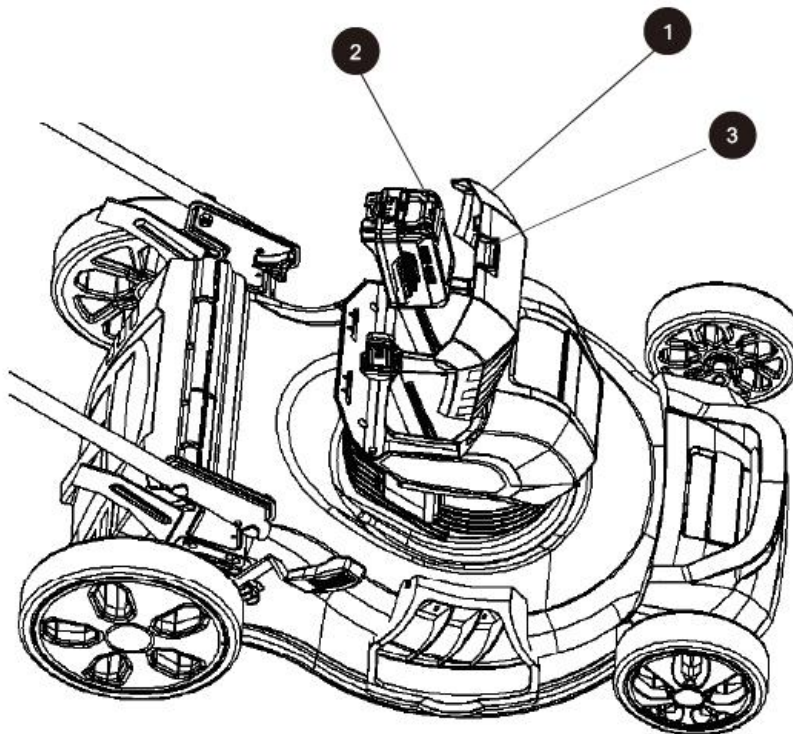
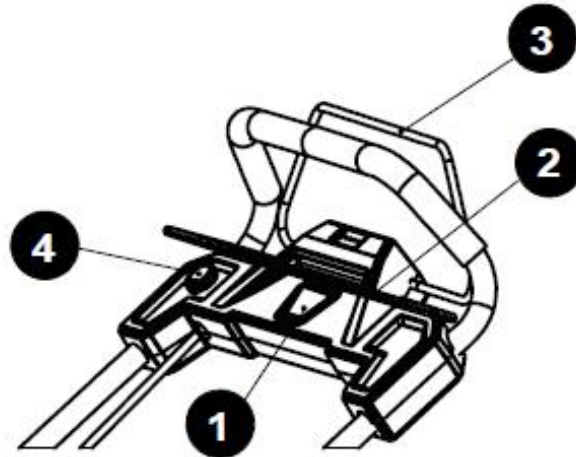

Fig.E

4. OPERATION

a. **Starting/stopping(Fig.F)**

- Open the battery cover.
- Install battery.
- Close the battery cover.
- Press and hold the safety lock-out button(1)
- Pull the bail level(2) upward to the handle to start the mover and release the button
- To stop the mower, release the bail level(2)



(Fig.F)

b. **To operate the self-propel system(Fig.F)**

- Pull the self-propel control bar(3) to the handle.
- To turn the self propel off, release the self-propel control bar (3).

The system has variable speed. To increase the speed, turn the self-propel speed control knob (4) counterclockwise. To decrease the speed, turn the self-propel speed control knob (4) clockwise.

c. **SOFT-START**

This LI-ION mower is equipped with a “soft- start” feature. When initially starting up, the mower will take approx. 3 seconds to get up to full speed. If the mower does not initially start: Remove the battery and check under the mower deck to ensure there is nothing obstructing the blade and that the blade can spin freely by hand. Even a small amount of grass on start up will prevent the “softstart” from turning the mower on.

CAUTION: Do not attempt to override the operation of the safety lock-out button or bail lever.

WARNING: The operation of any mower can result in foreign objects being thrown into the eyes, which can cause severe eye damage. Always wear safety glasses while operating the mower and while performing any adjustments or repairs.

WARNING: Ensure that other people and pets remain at least 100 feet (30 m) away when the mower is in use.

d. **INSPECT THE CUTTING AREA**

Remove all stones, sticks, wire, bones, and other debris that might be thrown by the rotating blades.

e. **CUTTING HEIGHT ADJUSTMENT**

When shipped, the wheels on the mower are set to a low-cutting position. Before using the mower for the first time, raise the cutting position to the height best suited for your lawn. The average lawn should be between 1” to 2” (2.5 to 5 cm) during cool months and between 2” and 3” (5 to 7.5 cm) during hot months.

TO ADJUST THE BLADE HEIGHT:

To raise the blade height, grasp the height adjustment lever (1) and move it toward the back of the mower. To lower the blade height, grasp the height adjustment lever (1) and move it toward the front of the mower.

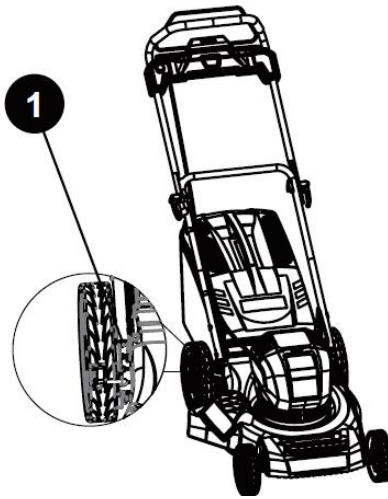

f. SLOPE GAUGE

WARNING:

Slopes are a major factor related to accidents involving slips and falls, which can result in severe injury. Operating the mower on a slope requires extra caution. If you feel uneasy on a slope, do not mow it. For your safety, use the slope gauge that is included as part of this manual to measure slopes before operating this unit on a sloped or hilly area.

- Mow across the face of a slope, and never up and down. Exercise extreme caution when changing direction on a slope.
- Watch for holes, ruts, rocks, hidden objects, or bumps that may cause a slip or a trip. Tall grass can hide obstacles.
- Always be sure of your footing. If you feel like you are losing your balance, release the blade/ motor control handle immediately. The blade will stop rotating within 3 seconds.
- Do not mow near drop-offs, ditches, or embankments, because you could lose your footing or balance.
- Do not mow a slope that has an angle of greater than 15° , as determined using the slope gauge.
- Do not mow wet or damp grass. Unstable footing can cause slipping.

WARNING:

Do not mow a slope that has an angle of greater than 15° (a rise of approximately 2 1/2 feet [.75 m] every 10 feet [3 m]). Mow across the face of a slope, and never up and down.

g. MOWING TIPS

NOTE: A sharp blade will greatly enhance the performance of the mower, especially when cutting high grass. Be sure to check the blade and to sharpen it at least once per year, as described in the Maintenance section.

- Verify that the lawn is free of stones, sticks, wires, and other objects that could damage the blades or the motor. These objects could be accidentally thrown by the mower in any direction, and could cause serious personal injury to the operator and to others. In order to prevent electric shock, do not operate the mower in damp or wet conditions.
- Do not mow in circles. Travel back and forth across the lawn.
- When cutting thick grass, reduce walking speed in order to allow for a more effective cut and a proper discharge of the clippings.
- For a healthy lawn, always cut off one-third or less of the total length of the grass. The average lawn should be approximately 1" to 2" (2.5 to 5 cm) long during cool months, and between 2" to 3 1/4" (5 cm to 8.3 cm) long during hot months. If there is growth, the lawn should be cut in the fall.

h. MULCHING TIPS

NOTE: Inspect the area where the mower is to be used, and remove all stones, sticks, wire, bones, and other debris that might be thrown by the rotating blade.

- Release the bail lever to turn the mower OFF when crossing any graveled area (stones can be thrown by the blade).
- Set mower to the highest cutting height when mowing on uneven ground or in tall weeds.
- For effective mulching, do not cut wet grass, because it tends to stick to the underside of the deck, preventing proper mulching of grass clippings. New or thick grass may require a narrower cut. The ground speed should be adjusted to the condition of the lawn. If mowing has been delayed and the

grass has been allowed to grow longer than 4" (10 cm), mow the lawn twice in order to reduce the grass height to a maximum of 3 1/4" (8.3 cm).

- Walk at a steady pace. Overlap the cutting rows. Do not let the grass get too tall. If the grass gets too long, start at the highest cutting position and work down to the desired cutting height.

WARNING:

If you strike a foreign object, stop the motor and remove the battery.

Thoroughly inspect the mower for any damage. Repair any damage before operating the mower. Excessive vibration of the mower during operation is an indication of damage. Thoroughly inspect the mower and repair any damage before operating the mower.

i. **EMPTYING THE GRASS CATCHER BAG**

- Stop mower, allow blades to completely stop, and remove the battery.
- Lift the rear discharge cover.
- Lift the grass catcher bag by its handle to remove from mower.
- Empty grass clippings.
- Lift the rear discharge cover and reinstall the grass catcher bag as described earlier in this manual.

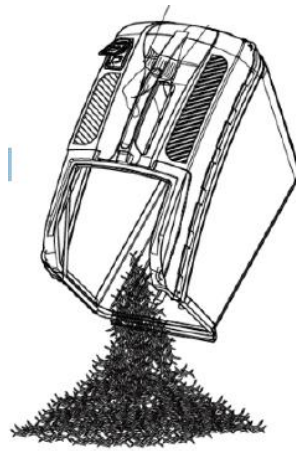

j. **BATTERY AND CHARGER**

1

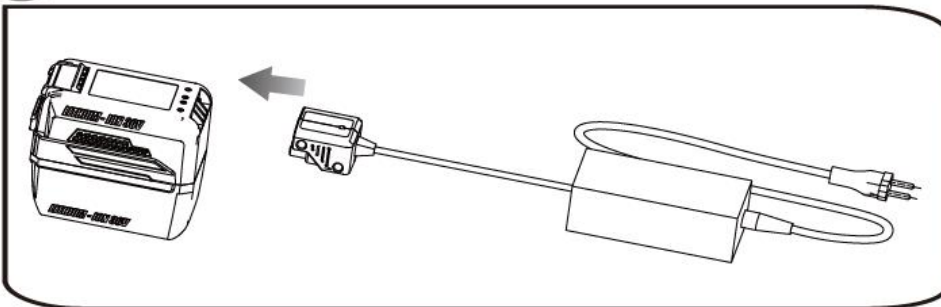

2

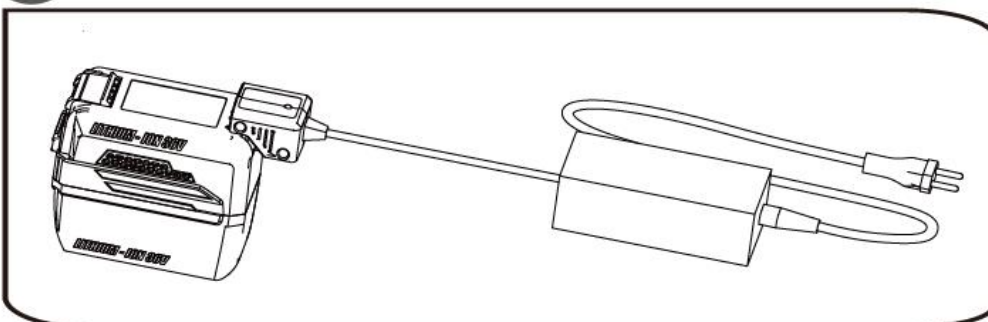

5. CARE AND MAINTENANCE

a. Replacing the cutting blade

WARNING

Always protect your hands by wearing heavy gloves and/or wrapping the cutting edges with rags or other materials when performing any maintenance on the blades. ALWAYS remove the battery when servicing or transporting the mower.

REMOVE BATTERY

While wearing leather padded gloves, wedge a block of wood between the blade and the mower deck in order to prevent the blade from turning when the bolt (1) is being removed.

- Using an adjustable wrench or 27 mm socket, loosen the bolt (1) and remove the blade (2). Turn the bolt “COUNTERCLOCK WISE” to loosen it and “CLOCKWISE” to tighten it.
- Remove the bolt (1) and the blade (2).
- To re-install the blade, position the blade with the cutting edges toward the ground. Assemble the bolt as shown. Using a 27 mm socket or wrench, turn the blade nut “CLOCKWISE” in order to secure the blade.

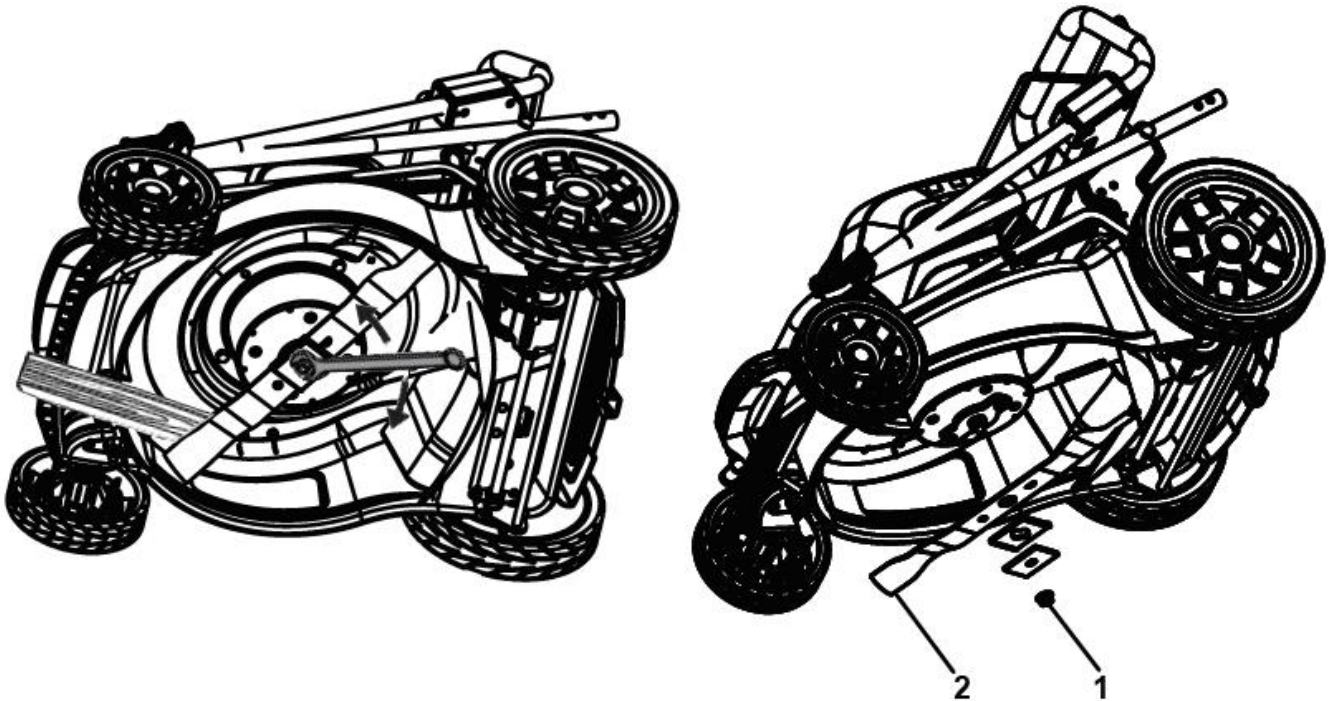

NOTE: Be sure to replace the parts in the exact order in which they were removed. When installing the cutting blade, verify that it is installed with the curved ends pointing toward the mower deck, and not toward the ground.

b. CLEANING THE MOWER

WARNING:

In order to reduce the risk of electric shock, do not expose the mower to water.

The underside of the mower deck should be cleaned after each use, because grass clippings, leaves, dirt, and other debris will accumulate, which will cause rust and corrosion.

Remove any build-up of grass and leaves on or around the motor cover (do not use water).

Occasionally wipe the mower clean with a dry cloth. If debris builds up on the underside of the mower during use, stop the motor, disconnect it from the battery, and then tilt the mower on its side, and scrape it clean using an appropriate tool.

6. SERVICE AND ADJUSTMENTS

- Identical replacement parts that are available from the manufacturer. In order to obtain replacement parts, the use of parts that do not meet the original equipment specifications may lead to improper performance, and may compromise safety.
- Before cleaning, repairing, or inspecting, verify that the blade and all moving parts have come to a complete stop. Remove the battery when making any adjustments or when any of the four wheels must be lifted off the ground.
- Keep the handles dry, clean, and free of oil and grease.
- In order to reduce the risk of fire, keep the motor free of grass, leaves, and debris build-up.
- Check the blade and motor mounting bolts for proper tightness frequently. Visually inspect blade for damage (e.g., bent, cracked, or worn).
- For best and safest performance, maintain the mower with care. Keep the mower blade sharp and clean. Mower blades are sharp, and can cut. Wrap the blades or wear gloves, and use extra caution when servicing.
- Keep all nuts, bolts, and screws tight in order to be sure that the equipment is in safe working condition.
- Never tamper with safety devices. Check them regularly for proper operation.
- After striking a foreign object, stop the motor. Thoroughly inspect the mower for any damage. Repair any damage before operating the mower.
- The grass catcher components, discharge cover, and trail shield are subject to wear and damage, which could expose moving parts or allow objects to be thrown. As a safety precaution, check these components frequently, and immediately replace any parts that show signs of wear, or that are cracked or broken. Use original equipment manufacturer's parts only.
- When it is not in use, store the mower indoors in a dry area, and out of the reach of children.

WARNING:

Always remove battery when servicing or transporting the mower.

PROBLEM	POSSIBLE CAUSE	SOLUTION
The mower does not start.	The battery is not charged.	Charge the battery.
	The switch is defective.	Replace the switch
	Grass jammed between the deck and blade.	Remove battery; check under deck for jams.
	The battery is not fully inserted in the mower.	Check the connection between the battery and the mower. Make sure the battery clicks into place.
	Battery may require service or replacement.	Replace battery
The mower cuts the grass unevenly.	The lawn is rough or uneven.	Check the mowing area.
	The cutting height is not set properly.	Move the wheels to a higher setting.
The mower does not mulch properly.	Wet grass clippings are sticking to the underside of the deck.	Wait until the grass dries before mowing.
	The mulching plug is missing.	Install the mulching plug.
The mower does not mulch properly.	Wet grass clippings are sticking to the underside of the deck.	Wait until the grass dries before mowing.
	The mulching plug is missing.	Install the mulching plug.
The mower is hard to push.	The grass is too tall, or the cutting height is too low.	Raise the cutting height.
	The rear of the grass catcher bag is dragging in thick grass.	Empty the grass clippings from the grass catcher bag.
The mower is excessively noisy and vibrates.	The motor shaft is bent.	Stop the motor, and inspect for damage.
	The blade is unbalanced.	Repair before restarting.

7. TRANSPORTING LITHIUM BATTERIES

Transport the battery in accordance with local and national provisions and regulations.

Follow all special requirements on packaging and labelling when transporting batteries by a third party.

Ensure that no batteries can come in contact with other batteries or conductive materials while in transport by protecting exposed connectors with insulating, non-conductive caps or tape. Do not transport batteries that are cracked or leaking. Check with the forwarding company for further advice.

WARNING

Not intended for use other than what's listed above.

8. RECYCLING AND DISPOSING

When you decide to get rid of the machine, make sure to follow the local regulation.

The batteries used in this mower's battery pack contain the following toxic and corrosive material: LITHIUM-ION.

WARNING

Toxic materials must be disposed of in a specified manner in order to prevent contamination of the environment. Before disposing of damaged or worn out Lithium-Ion battery packs, contact your local waste disposal agency for information and specific instructions. Take the battery to a local recycling and/or disposal centre that are certified for disposal. If the battery pack cracks or breaks, whether it leaks or not, do not recharge it and do not use it. Dispose of it and replace it with a new battery pack. **DO NOT ATTEMPT TO REPAIR IT!**

Follow these instructions in order to avoid injury and the risk of fire, explosion, or electric shock, and to avoid damage to the environment:

- Cover the battery's terminals with heavy-duty adhesive tape.
- Do not attempt to remove or destroy any of the components of the battery pack.
- Do not attempt to open the battery pack.
- If a leak develops, the electrolytes that are released are corrosive and toxic. Do not get the solution in the eyes or on the skin, and do not swallow it.
- Do not place batteries in regular household trash.
- DO NOT incinerate batteries.
- DO NOT place batteries where they will become part of any waste landfill or municipal solid waste stream.

Package materials are recyclables. Please, throw them away on the appropriate trash can.



Electrical products should not be discarded with household products. According to the European Directive 2012/19/EU on waste electrical and electronic equipment and its implementation into national law, electrical products used must be collected separately and disposed of at collection points provided for this purpose. Talk with your local authorities or dealer for advice on recycling.

9. CE DECLARATION OF CONFORMITY



BUILDER SAS
32, rue Aristide Bergès -Z1 31270 Cugnaux - France
Tel. +33 (0) 5.34.502.502 Fax: +33 (0) 5.34.502.503

Declares that the machine named below
Cordless LAWNMOWER
HTDEN4640VT
Serial number: 20210133831-20210133990

Complies with the following European Directives:
Machinery Directive 2006/42/EC
EMC Directive 2014/30/EU

Other applicable Directives:
Noise Directive 2000/14/EC Annex VI and 2005/88/EC

Measured sound power level: 91 dB(A) K= 3 dB(A)
Guaranteed Sound Power Level: 94 dB(A)

Notified body 0359
Intertek Testing & Certification Ltd.
Davy Avenue, Knowlhill, Milton Keynes, MK5 8NL
Telephone: +44 (0)1908 857777 Fax: +44 (0)1908 857830
Web: www.intertek.com

Applicable harmonized standards:
EN60335-1:2012+A1:2014
EN60335-2-77:2010
EN62233:2008
EN55014-1:2017
EN55014-2:2015

Cugnaux, 21/10/2020

Philippe MARIE / CEO

Responsible of technical file: M. Olivier Patriarca

10. WARRANTY

HYUNDAI

WARRANTY

The manufacturer guarantees the product against defects in material and workmanship for a period of 2 years from the date of the original purchase. The warranty only applies if the product is for household use. The warranty does not cover breakdowns due to normal wear and tear.

The manufacturer agrees to replace parts identified as defective by the designated distributor. The manufacturer does not accept responsibility for the replacement of the machine, in whole or in part, and/or ensuing damage.

The warranty does not cover breakdowns due to:

- insufficient maintenance.
- abnormal assembly, adjustment or operations of the product.
- parts subject to normal wear and tear.

The warranty does not extend to:

- shipping and packaging costs.
- using the tool for a purpose other than that for which it was designed.
- the use and maintenance of the machine done in a manner not described in the user manual.

Due to our policy of continuous product improvement, we reserve the right to alter or change specifications without notice. Consequently, the product may be different from the information contained therein, but a modification will be undertaken without notice if it is recognized as an improvement of the preceding characteristic.

READ THE MANUAL CAREFULLY BEFORE USING THE MACHINE.

When ordering spare parts, please indicate the part number or code, you can find this in the spare parts list in this manual. Keep the purchase receipt; without it, the warranty is invalid. To help you with your product, we invite you to contact us by phone or via our website:

- **+33 (0)9.70.75.30.30**
- **<https://services.swap-europe.com/contact>**

You must create a "ticket" via the web platform.

- Register or create your account.
- Indicate the reference of the tool.
- Choose the subject of your request.
- Describe your problem.
- Attach these files: invoice or sales receipt, photo of the identification plate (serial number), photo of the part you need (for example: pins on the transformer plug which are broken).



11. PRODUCT FAILURE

WHAT TO DO IF MY MACHINE BREAKS DOWN?

If you bought your product in a store:

- a) Empty the fuel tank.
- b) Make sure that your machine is complete with all accessories supplied, and clean! If this is not the case, the repairer will refuse the machine.

Go to the store with the complete machine and with the receipt or invoice.

If you bought your product on a website:

- a) Empty the fuel tank.
- b) Make sure that your machine is complete with all accessories supplied, and clean! If this is not the case, the repairer will refuse the machine.
- c) Create a SWAP-Europe service ticket on the site: <https://services.swap-europe.com> When making the request on SWAP-Europe, you must attach the invoice and the photo of the nameplate (serial number).
- d) Contact the repair station to make sure it is available before dropping off the machine.

Go to the repair station with the complete machine packed, accompanied by the purchase invoice and the station support sheet downloadable after the service request is completed on the SWAP-Europe site

For machines with engine failure from manufacturers BRIGGS & STRATTON, HONDA and RATO, please refer to the following instructions.

Repairs will be done by approved engine manufacturers of these manufacturers, see their site:

- <http://www.briggsandstratton.com/eu/fr>
- <http://www.honda-engines-eu.com/fr/service-network-page;jsessionid=5EE8456CF39CD572AA2AEEDFD290CDAE>
- <https://www.rato-europe.com/it/service-network>

Please keep your original packaging to allow for after-sales service returns or pack your machine with a similar cardboard box of the same dimensions.

For any question concerning our after-sales service you can make a request on our website <https://services.swap-europe.com>

Our hotline remains available at +33 (9) 70 75 30 30.



12. WARRANTY EXCLUSIONS

THE WARRANTY DOES NOT COVER:

- Start-up and setting up of the product.
- Damage resulting from normal wear and tear of the product.
- Damage resulting from improper use of the product.
- Damage resulting from assembly or start-up not in accordance with the user manual.
- Breakdowns related to carburetion beyond 90 days and fouling of carburetors.
- Periodic and standard maintenance events.
- Actions of modification and dismantling that directly void the warranty.
- Products whose original authentication marking (brand, serial number) has been degraded, altered or withdrawn.
- Replacement of consumables.
- The use of non-original parts.
- Breakage of parts following impacts or projections.
- Accessories breakdowns.
- Defects and their consequences linked to any external cause.
- Loss of components and loss due to insufficient screwing.
- Cutting components and any damage related to the loosening of parts.
- Overload or overheating.
- Poor power supply quality: faulty voltage, voltage error, etc.
- Damages resulting from the deprivation of enjoyment of the product during the time necessary for repairs and more generally the costs related to the immobilization of the product.
- The costs of a second opinion established by a third party following an estimate by a SWAP-Europe repair station
- The use of a product which would show a defect or a breakage which was not the subject of an immediate report and/or repair with the services of SWAP-Europe.
- Deterioration linked to transport and storage*.
- Launchers beyond 90 days.
- Oil, petrol, grease.
- Damages related to the use of non-compliant fuels or lubricants.

* In accordance with transport legislation, damage related to transport must be declared to carriers within 48 hours maximum after observation by registered letter with acknowledgement of receipt.

This document is a supplement to your notice, a non-exhaustive list.

Attention: all orders must be checked in the presence of the delivery person. In case of refusal by the delivery person, it you must simply refuse the delivery and notify your refusal.

Reminder: the reserves do not exclude the notification by registered letter with acknowledgement within 72 hours.

Information:

Thermal devices must be wintered each season (service available on the SWAP-Europe site). Batteries must be charged before being stored.

HYUNDAI
POWER PRODUCTS

For Inquiries, please contact:

BUILDER SAS

32, rue Aristide Bergès Z1 31270 Cugnaux, France

Tél. : +33 (0) 5.34.502.502 Fax : +33 (0) 5.34.502.503

<http://www.hyundaipower-fr.com/>

Fabriqué en République Populaire de Chine (PRC)