

HYUNDAI
POWER PRODUCTS

HIGH PRESSURE WASHER ELECTRIC

HNHP2500SP-195i6

ORIGINAL INSTRUCTIONS

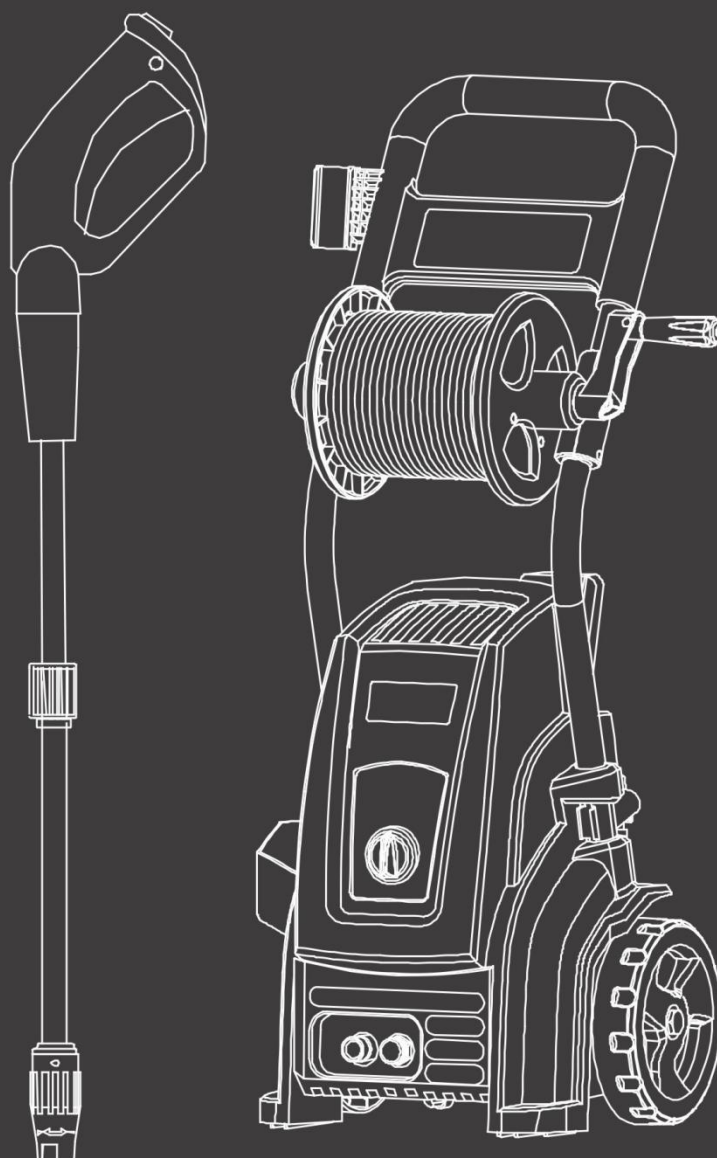

1. SAFETY INSTRUCTIONS

- **Use this unit as described in this manual. Any mishandling and any use contrary to instructions for use shall in no case be the responsibility of the manufacturer.**
- **Failure to observe the safety and operating instructions may result in a risk of electric shock, fire and / or personal injury.**
- **If you are giving this unit to another person, please also provide this manual.**
- **Do not use attachments other than those recommended by the manufacturer; they can damage the unit and / or cause injury.**
- **This machine should not be used by children. Children should be supervised to ensure that they do not play with the appliance.**
- **This machine can be used by people with reduced physical, sensory or mental capabilities or lack of experience and knowledge if they have been given supervision or instruction concerning use of the machine in a safe way and understand the hazards involved.**

- **Children shall not play with the appliance.**
- **If the supply cord is damaged, it must be replaced by the manufacturer, its service agent or similarly qualified persons in order to avoid a hazard.**
- **Before any connection, check:**
 - **The appliance, power cable and accessories are not damaged. In this case, do not use the appliance and take it to your dealer for inspection and repair.**
 - **The voltage indicated on the rating plate of the appliance corresponds to that of your electrical installation.**
- **Do not disassemble the device yourself. Any disassembly, repair or inspection should be carried out exclusively by a qualified person.**
- **Do not touch the plug with wet hands. Do not allow the plug to fall into the water.**
- **Do not walk on the power cord, do not exert excessive pressure, or pull on the cord to avoid damage.**
- **WARNING: This machine is intended for use with a cleaning agent supplied or**

recommended by the manufacturer. Use of other cleaning or chemical agents may affect the safety of the machine.

- **WARNING: High pressure jets can be dangerous if misused. The jets should not be directed to people, electrical equipment or the machine itself.**
- **WARNING: Do not use the machine near people unless they wear protective clothing.**
- **Do not direct the jet against yourself or others to clean clothes or footwear.**
- **WARNING: Risk of explosion. Do not spray flammable liquids.**
- **WARNING: High pressure cleaners should not be used by children or untrained persons.**
- **WARNING: Pipes, fittings and connectors are important for the safety of the machine. Only use hoses, fittings and connectors recommended by the manufacturer.**
- **WARNING: To ensure the safety of the machine, use only the original manufacturer's parts or approved by the manufacturer.**
- **WARNING: Water that has flowed through the**

flow shutters is considered to be unsafe.

- **WARNING: The machine must be disconnected from the power supply during cleaning or maintenance and when replacing parts or converting the machine to other functions by removing the power source plug.**
- **WARNING: Do not operate the machine if the power cord or any important parts are damaged, such as safety devices, high pressure hoses or the trigger gun.**
- **WARNING: If an extension cord is used, the plug and cable must be watertight.**
- **WARNING Inadequate extension cords can be dangerous. If an extension cord is used, it shall be suitable for outdoor use, and the connection has to be kept dry and off the ground. It is recommended that this is accomplished by means of a cord reel which keeps the socket at least 60 mm above the ground.**
- **WARNING: Make sure there are no exhaust emissions near the air intakes.**
- **Children, animals and persons not participating in the use of the machine must**

remain at a minimum distance of 10 meters from the sprayer.

- **The high pressure hose must remain connected to the compressor as long as the system is under pressure.**
- **Do not use corrosive or flammable liquids in the machine.**
- **The appliance must be connected to a water supply using a new set of hoses; the old pipe set must not be reused.**
- **Make sure that there are no exhaust emissions near the air inlets.**
- **When using the machine, wear protective equipment including safety goggles, safety shoes, safety gloves, safety helmet with visor and double-insulated hearing protection.**
- **In order to move the unit easily, bend the lance. Make sure the unit is turned off and unplugged before transporting the unit.**
- **The connection to the power supply must be made by a qualified electrician in accordance with IEC60364-1. It is recommended that the power supply of this machine includes a residual current**

device that interrupts power if the earth leakage exceeds 30 mA for 30 ms or a device that will homologate the earth circuit.

- **Before assembling, dismantling, repairing, transporting, servicing and storing, please check if the appliance is disconnected from the power supply.**
- **Handle the unit with care, do not drop it.**
- **Do not use the machine in extreme weather conditions, when it is very cold. Do not use the machine with ice water.**
- **Use the tool in a stable and plane location.**
- **The inlet hose can be connected to the water mains with a maximum pressure of 10 bars.**
- **The appliance must not be connected to potable water supply.**
- **CAUTION: In order to avoid danger due to untimely resetting of the thermal cut-out, this device must not be powered by an external switch, such as a timer, or connected to a circuit that is regularly switched on energized and de-energized by the electricity supplier.**
- **When transporting the machine, take note of its**

weight. Do not overestimate your efforts and get help if necessary.

- **The machine must be transported from one point to another and disconnected. Always use the handle to push the machine.**
- **Use the handle to lift the machine.**
- **Improper transport of the machine may result accidents and injuries.**
- **During use, transportation, assembly, dismantling when out of service, testing or foreseeable breakdowns, the tool must keep always stand up.**
- **Do not use the tool where dangerous situations or accidents may occur. Do not use it indoor, in places where are exhausted gases, etc.**
- **In case of accidents or breakdowns, stop to use the tool, switch off it and unplug it. Check the conditions of the tool and bring it to a service agent for inspection and reparation if necessary.**
- **When opening the trigger gun, pay attention**

to the kickback force. The power of the gun can cause a kickback and can produce a loss of control of the gun and create accidents and injuries. Hold the gun firmly, and with both hands if possible.

- **WARNING Always switch off the mains disconnecting switch when leaving the machine unattended.**

- **Means for disconnection must be incorporated in the fixed wiring in accordance with the wiring rules.**

Intended Use

Your PRESSURE CLEANER can perform a myriad of tasks in the house and in the garden. It effectively cleans a wide variety of surfaces.

Your PRESSURE CLEANER is designed to operate from a cold water supply. It operates efficiently with water whose temperature is between 5 and 50 degrees.

Your PRESSURE CLEANER has been designed for outdoor use only on materials such as stone, wood and plastics. Please check, before use, whether materials can be cleaned with your sprayer; the manufacturer cannot be held responsible for any damage resulting from improper use.

The main applications of this product are household cleaning tasks such as:

- Vehicles, motorcycles, bicycles;
- Patios, grates, garden walls, pathways, garages and facades of houses;
- To remove algae and mosses from roofs, brick walls and gutters;
- For cleaning of gardening tools and machinery, furniture and grills;
- For hygiene and maintenance of kennels, stables, etc. And their surroundings;

It is especially useful for cleaning muddy sidings.

The sprayer alone is capable of performing most of the garden cleaning tasks or on buildings. The detergent is useful for cleaning vehicles and other painted surfaces.

Symbol



WARNING! The jet should not be directed to persons, animals, live devices or the device itself.



This machine is not suitable for connection to potable water supply.



Guaranteed sound power level

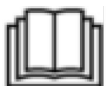

Read the instruction manual

2. YOUR PRODUCT

a. Description

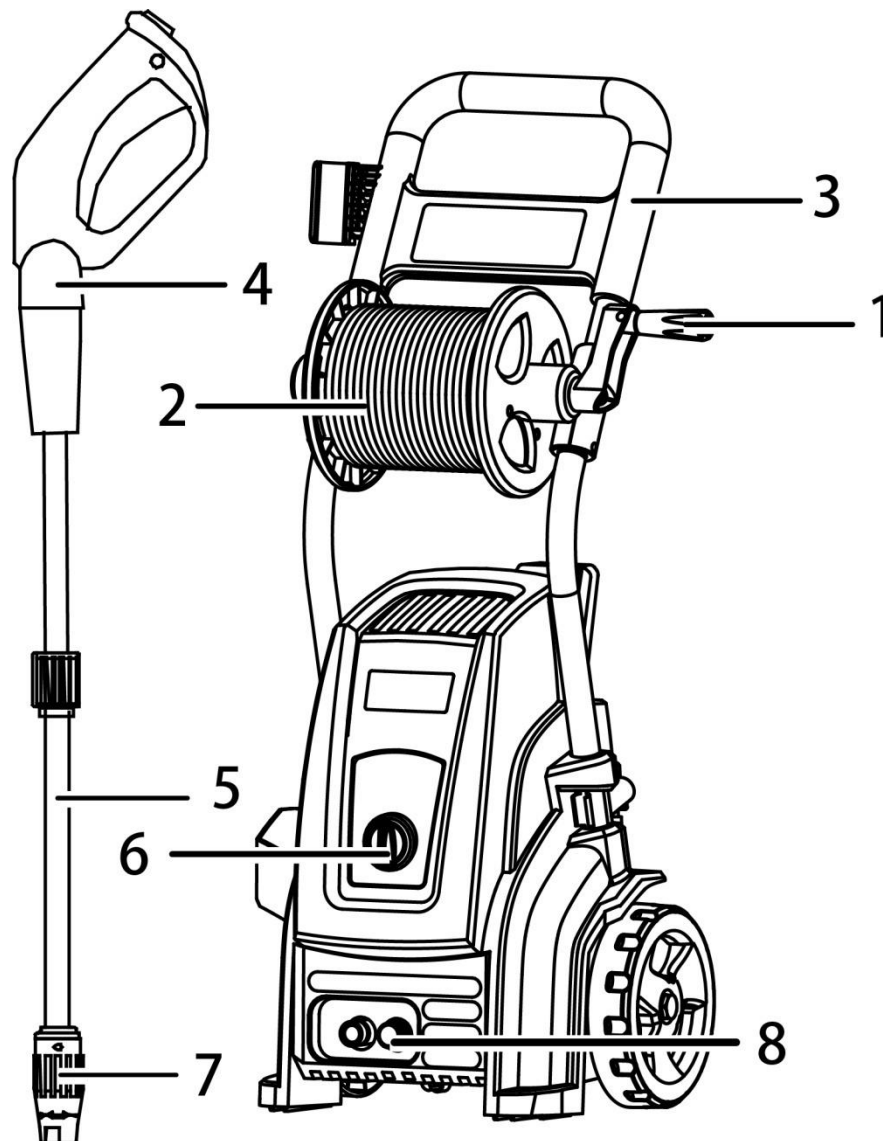

1. Hose unwinding handle
2. High-pressure hose
3. Carry handle
4. Gun
5. Lance
6. on / off switch
7. Nozzle
8. Water supply connection

b. Electrical circuit

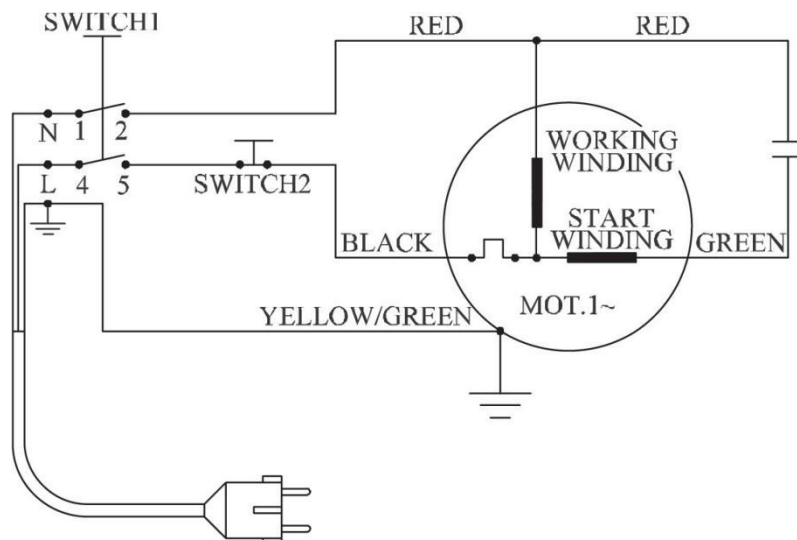

c. Technical specifications

Model	HNHP2500SP-195i6
Voltage	230 V~ 50Hz
Assigned pressure	13 MPa
Maximum pressure	19.5 MPa (Maximum allowable pressure)
Max. inlet water pressure	0,4 MPa
Assigned speed	7,0 l/min
Maximum flow	8,75 l/min
Power	2500 W
Vibration	Max. Rear handle: 4,271 m/s ² Front handle: 1,154 m/s ² K=1,5 m/s ²
Sound emission	Lpa: 80,9 dB(A) K = 3 dB Lwa: 93,7 dB K = 3 dB
Net weight	22 kg
Maximum temperature of the water	5 ~ 50 °C

Regarding the methods used for the measurement of noise emissions in the air, the requirements of the standard EN 60335-2-79 have been applied.

3. INSTALLATION AND CONNECTIONS

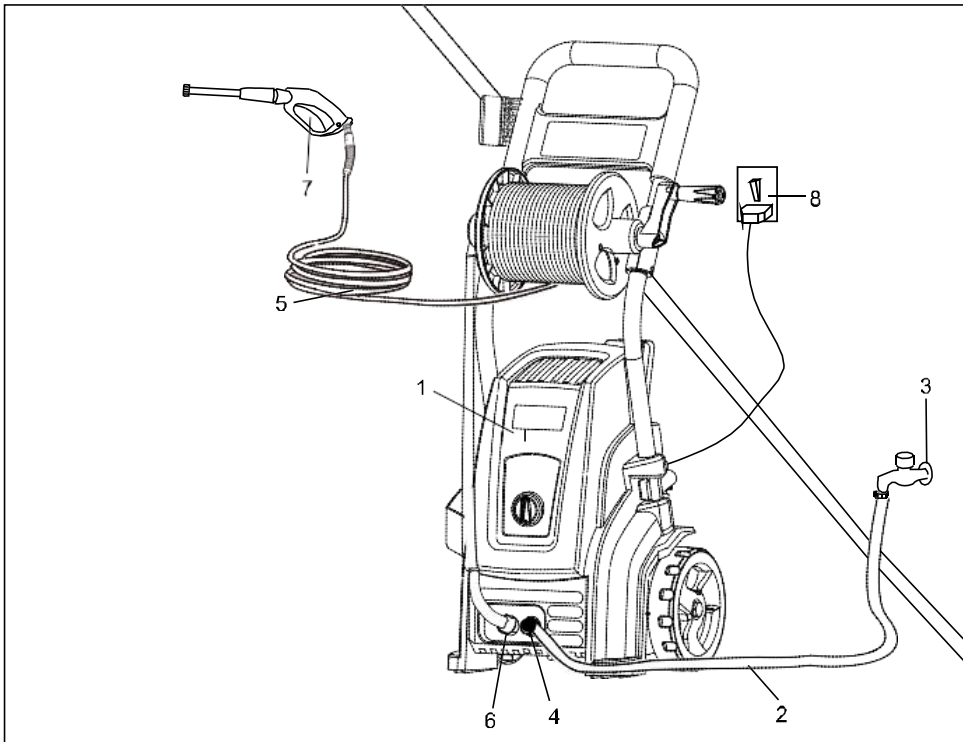

Connecting pipes

Note: The inlet filter must always be installed to filter out sand, limestone and other impurities as these may damage the valves of the pump.

- Install the high-pressure hose to the trigger gun and screw it in place (5, 7).
- Connect the machine to the water supply (2, 3 and 4). The minimum length recommended for the water supply pipe is 10 meters (but not exceeding 25 meters) with a diameter of 12.5 mm to avoid counter-pressures and the risk of potential damage to your device. Make sure that it can withstand the water and a maximum pressure of 10 bar (0.1 Mpa). If you want to connect your device to other water sources, make sure that the maximum water input pressure is 10 bar (0.1 Mpa).
- Connect and screw the high pressure hose to the water outlet (6) of the machine.
- Plug the tool to the electrical supply (8).

Install the lance on the gun

- Install the lance on the gun and screw it in place.

Adjusting the nozzle

- High pressure

Trigger must be released; water must not come out of nozzle. Turn the nozzle counter clockwise. Press the trigger, the water comes out at high pressure.



- Low pressure

Trigger must be released; water must not come out of nozzle. Turn the nozzle clockwise. Press the trigger, the water comes out at low pressure.

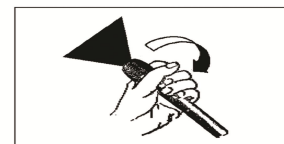

4. USE

a. Before starting the machine

NOTE: Never operate the sprayer without first opening the water supply!

Never open the lid of the sprayer while it's running. Do not use the sprayer in dangerous environments and in places where explosive substances are stored.

Do not put water in materials containing asbestos and other materials that can be dangerous to health

Do not use liquids containing organic solvents, oil-based acids or solvent, paint or oil having highly flammable, explosive and toxic vapors. Compounds like acetone, acids and solvents are corrosive and may damage the device.

Open the tap, but do not start the machine immediately.

Press the gun trigger until the air has been expelled from the sprayer and water begins to flow. Once the water begins to flow to the nozzle, release the trigger. The sprayer is now running. Now you can turn the unit on.

b. Start/Stop

Turn the power switch to ON.

Press and hold down the gun trigger to start working.

Release the trigger to momentarily stop working and then re-press it to start again.

Keeps a suitable distance according to room being treated.

To work further on, unroll the hose using the unwinder handle.

If you need to stop using the device for more than 2 minutes, please turn it off.

At the end of the operation, release the trigger.

Turn off the machine by turning the power switch OFF and unplug the power outlet. Press the gun trigger to release pressure.

NOTE: The trigger gun features a locking device. When this locking device is activated, the trigger gun cannot be operated.

c. Use with detergent

Open the cap and pour the detergent into the container (the bottle is located to the rear of the machine).

Note: make sure that the machine is switched off before you fill the detergent.

NOTE: detergents can be purchased in gardening stores and on the web.

The use of detergent may help reducing the working time and contribute removing stubborn dirt. Some detergents are specially designed to be used with high-pressure cleaners for specific cleaning operations. The viscosity of these detergents is close to that of water. If you use detergents having a higher viscosity, for instance a dishwashing liquid, the detergent injection system may clog and you will not be able to spray the detergent.

Detergents can clean a surface only if they are applied long enough on the surface so that their chemical agents may degrade dirt and grime. They are most effective if they are applied

at low pressure.

The combination of the action of the chemical agents and rinsing with high pressure is very effective in removing dirt. On vertical surfaces, apply the detergent starting from the bottom moving upwards. This will prevent the detergent flowing downwards and forming trails. Similarly, you need to rinse the surface from the bottom upwards.

To remove particularly stubborn dirt, using a brush in a combination with a detergent and a high-pressure rinse may be necessary.

The next cleaning procedure will help you to better organize your cleaning and obtain optimal results in minimum time:

- A. Before starting, prepare the surface to be cleaned; remove furniture from the working area and ensure windows and doors are properly closed. Protect or remove any hazardous materials and any object that may be damaged.
- B. Then spray the surface to be cleaned with the high-pressure water jet to remove dirt on the surface. Before you press the trigger adjust the nozzle for a cone jet and slowly adjust the shape of the jet until you get the desired result. Thus, you avoid spraying the surface with a jet that could be too powerful and could cause damage.
- C. Start the final rinse from the bottom of the surface moving upwards. Make sure rinsing the surface so that not even the slightest trace of detergent remains.

5. CARE AND MAINTENANCE

The machine must be switched off and unplugged before any cleaning, maintenance and replacement of parts. Perform maintenance on this machine regularly according to these instructions to keep it in good working condition and extend its life.

Always check the high-pressure hose and connectors regularly to ensure there aren't any damage or issues, as these are essential elements for the machine. Do not use them if they are damaged.

After each use, perform the following actions:

- Check the cap to verify that it's not blocked by dirt. If necessary, clean the tip and then rinse it with cold water.
- Remove the water inlet screen and make sure it is not obstructed. If it is dirty, wipe and rinse it. When you remove the filter, always put it back in place after cleaning.
- Wash the hoses, connectors and accessories.
- Clean each time the detergent sprayer and sprays.
- Verify that the air vents are not blocked. Clean the vents if they are dirty.

Other maintenance services:

- Grease regularly the fittings so that the joints do not dry up.
- Bring your machine one or twice a year to a qualified technical service for a general inspection of your device.

NOTE: If repairs need to be made, they should only be performed by personnel belonging to an approved technical center or qualified technicians.

6. STORAGE

Proceed to its cleaning and remove the hoses and accessories before storage. Check that there isn't any water in the pipes.

Store the machine, hoses and accessories together in a safe and dry, protected from moisture and frost.

The machine should be stored in order to be out of the reach of children.

You can install the accessories (multiple jet, turbo nozzle and jet cleaner) behind the machine.

7. DISPOSAL



Electrical products should not be disposed of with household products. According to the European Directive 2012/19/EU for electrical and electronic equipment waste and its implementation in national law, used electrical products should be collected separately and disposed of at collection points provided for this purpose. Consult with your local authorities or your dealer for advice on recycling.

8. TROUBLESHOOTING

This troubleshooting guide can help you solving a problem that occurred on the machine. If you can't solve the problem, please contact directly the customer service.

Problems	Causes	Possible solutions
The machine does not start	The machine is not plugged in	Connect the machine to a suitable outlet
	Defective plug	Change the plug or have your electrical installation inspected
	The fuse is blown	Change the fuse with a similar one
	Defective extension cable	Use the machine without the extension cable and change the defective cable
Fluctuations of pressure	The pump sucks the air	Check that hoses and fittings are waterproof.
	Dirty, worn or jammed valves	Contact your service center
	The water supply is not enough	Increase the water pressure, check for blockage of the hose and / or change the large hose.
	Worn out pump seals	The machine stops. The fuse is blown
The machine stops	The fuse is blown	Replace the fuse.
	Mains voltage incorrect	Disconnect the other machines.
		Check that the mains voltage corresponds to the specification on the nameplate
	Thermal sensor activated	Let the machine cool down for 5 minutes
Jet is partially blocked	Clean the jet with a needle and spray some water toward the rear through the jet	

The fuse is blown	Too small fuse	Replace with a higher fuse.
	Increase the amperage	Try without the extension cable
Pulsation of the machine	Air in the inlet hose / pump	Let the machine operate with the open trigger until the working pressure resumes regularly.
	Inadequate supply	Increase the water pressure, check for blockage of the hose or change the large hose
	Jet is partially blocked	Clean the jet with a needle and spray some water toward the rear through the jet
	Blocked water filter	Clean the filter
	Hose bending	Straighten the hose.
The machine starts and stops automatically	Leaky shotgun and/or trigger	Contact your nearest service center
The machine starts, but the water does not come out	No water supply	Connect the water inlet.
	Blocked water filter	Clean the filter
	Blocked jet	Clean the jet with a needle and spray some water toward the rear through the jet

9. EC DECLARATION OF CONFORMITY



Declaration of conformity
BUILDER SAS
ZI, 32, rue Aristide Bergès-31270 CUGNAUX France

Declares that the machine designated below
HIGH PRESSURE WASHER ELECTRIC
HNHP2500SP-195i6

Serial number: 20210503201-20210503560

Is in conformity with the provisions of the Machinery Directive 2006/42/EC and to the national regulations transposing it.

Also complies with the provisions of the following European Directives:

EMC Directive 2014/30/EU
Directive ROHS (EU)2015/863 amending 2011/65/EU
Directive 2000/14/EC + 2005/88/EC

Also complies with European and national standards and the following technical provisions:

EN60335-1:2012+A11:2014+A13:2017+A1:2019+A14:2019+A2:2019;
EN60335-2-79:2012
EN 55014-1:2017
EN 55014-2:2015;
EN IEC61000-3-2:2019;
EN61000-3-3:2013

Cugnaux on 28/12/2020

A handwritten signature in black ink, appearing to read 'Philippe Marie', with a large, sweeping flourish at the end.

Philippe MARIE / CEO

10. WARRANTY

HYUNDAI

WARRANTY

The manufacturer guarantees the product against defects in material and workmanship for a period of 2 years from the date of the original purchase. The warranty only applies if the product is for household use. The warranty does not cover breakdowns due to normal wear and tear.

The manufacturer agrees to replace parts identified as defective by the designated distributor. The manufacturer does not accept responsibility for the replacement of the machine, in whole or in part, and/or ensuing damage.

The warranty does not cover breakdowns due to:

- insufficient maintenance.
- abnormal assembly, adjustment or operations of the product.
- parts subject to normal wear and tear.

The warranty does not extend to:

- shipping and packaging costs.
- using the tool for a purpose other than that for which it was designed.
- the use and maintenance of the machine done in a manner not described in the user manual.

Due to our policy of continuous product improvement, we reserve the right to alter or change specifications without notice. Consequently, the product may be different from the information contained therein, but a modification will be undertaken without notice if it is recognized as an improvement of the preceding characteristic.

READ THE MANUAL CAREFULLY BEFORE USING THE MACHINE.

When ordering spare parts, please indicate the part number or code, you can find this in the spare parts list in this manual. Keep the purchase receipt; without it, the warranty is invalid. To help you with your product, we invite you to contact us by phone or via our website:

- **+33 (0)9.70.75.30.30**
- **<https://services.swap-europe.com/contact>**

You must create a "ticket" via the web platform.

- Register or create your account.
- Indicate the reference of the tool.
- Choose the subject of your request.
- Describe your problem.
- Attach these files: invoice or sales receipt, photo of the identification plate (serial number), photo of the part you need (for example: pins on the transformer plug which are broken).



11. PRODUCT FAILURE

WHAT TO DO IF MY MACHINE BREAKS DOWN?

If you bought your product in a store:

- a) Empty the fuel tank.
- b) Make sure that your machine is complete with all accessories supplied, and clean! If this is not the case, the repairer will refuse the machine.

Go to the store with the complete machine and with the receipt or invoice.

If you bought your product on a website:

- a) Empty the fuel tank.
- b) Make sure that your machine is complete with all accessories supplied, and clean! If this is not the case, the repairer will refuse the machine.
- c) Create a SWAP-Europe service ticket on the site: <https://services.swap-europe.com> When making the request on SWAP-Europe, you must attach the invoice and the photo of the nameplate (serial number).
- d) Contact the repair station to make sure it is available before dropping off the machine.

Go to the repair station with the complete machine packed, accompanied by the purchase invoice and the station support sheet downloadable after the service request is completed on the SWAP-Europe site

For machines with engine failure from manufacturers BRIGGS & STRATTON, HONDA and RATO, please refer to the following instructions.

Repairs will be done by approved engine manufacturers of these manufacturers, see their site:

- <http://www.briggsandstratton.com/eu/fr>
- <http://www.honda-engines-eu.com/fr/service-network-page;jsessionid=5EE8456CF39CD572AA2AEEDFD290CDAE>
- <https://www.rato-europe.com/it/service-network>

Please keep your original packaging to allow for after-sales service returns or pack your machine with a similar cardboard box of the same dimensions.

For any question concerning our after-sales service you can make a request on our website <https://services.swap-europe.com>

Our hotline remains available at +33 (9) 70 75 30 30.



12. WARRANTY EXCLUSIONS

THE WARRANTY DOES NOT COVER:

- Start-up and setting up of the product.
- Damage resulting from normal wear and tear of the product.
- Damage resulting from improper use of the product.
- Damage resulting from assembly or start-up not in accordance with the user manual.
- Breakdowns related to carburetion beyond 90 days and fouling of carburetors.
- Periodic and standard maintenance events.
- Actions of modification and dismantling that directly void the warranty.
- Products whose original authentication marking (brand, serial number) has been degraded, altered or withdrawn.
- Replacement of consumables.
- The use of non-original parts.
- Breakage of parts following impacts or projections.
- Accessories breakdowns.
- Defects and their consequences linked to any external cause.
- Loss of components and loss due to insufficient screwing.
- Cutting components and any damage related to the loosening of parts.
- Overload or overheating.
- Poor power supply quality: faulty voltage, voltage error, etc.
- Damages resulting from the deprivation of enjoyment of the product during the time necessary for repairs and more generally the costs related to the immobilization of the product.
- The costs of a second opinion established by a third party following an estimate by a SWAP-Europe repair station
- The use of a product which would show a defect or a breakage which was not the subject of an immediate report and/or repair with the services of SWAP-Europe.
- Deterioration linked to transport and storage*.
- Launchers beyond 90 days.
- Oil, petrol, grease.
- Damages related to the use of non-compliant fuels or lubricants.

* In accordance with transport legislation, damage related to transport must be declared to carriers within 48 hours maximum after observation by registered letter with acknowledgement of receipt.

This document is a supplement to your notice, a non-exhaustive list.

Attention: all orders must be checked in the presence of the delivery person. In case of refusal by the delivery person, it you must simply refuse the delivery and notify your refusal.

Reminder: the reserves do not exclude the notification by registered letter with acknowledgement within 72 hours.

Information:

Thermal devices must be wintered each season (service available on the SWAP-Europe site). Batteries must be charged before being stored.

HYUNDAI
POWER PRODUCTS

For Inquiries, please contact:

BUILDER SAS

32, rue Aristide Bergès Z1 31270 Cugnaux, France

Tél. : +33 (0) 5.34.502.502 Fax : +33 (0) 5.34.502.503

<http://www.hyundaipower-fr.com/>

Fabriqué en République Populaire de Chine (PRC)