







Contents

Safety Points for Attention	1
Parts & Subassemblies	1
Check-ups before Operation	2
Starting of Generator	3
Usage of Generator	5
Stopping of Engine	6
Maintenance	7
Storage	8
Troubleshooting	9
Technical Data	10
Battery unit	10
Wheel unit	11

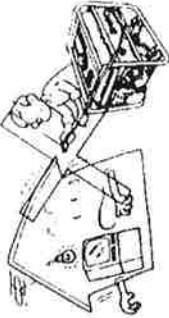
1. Safety points for Attention

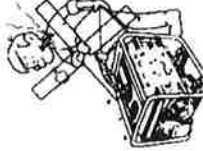
- 1) Do not use it indoors 
- 2) Do not operate it in wet environment 
- 3) Do not connect it to the line for house appliances. 
- 4) Keep flammables 1m min. away from it. 
- 5) Do not overfill to cause overflowing while fueling. 
- 6) Do not smoke while fueling. 
- 7) Stop the engine on fueling. 

2. Parts & Subassemblies

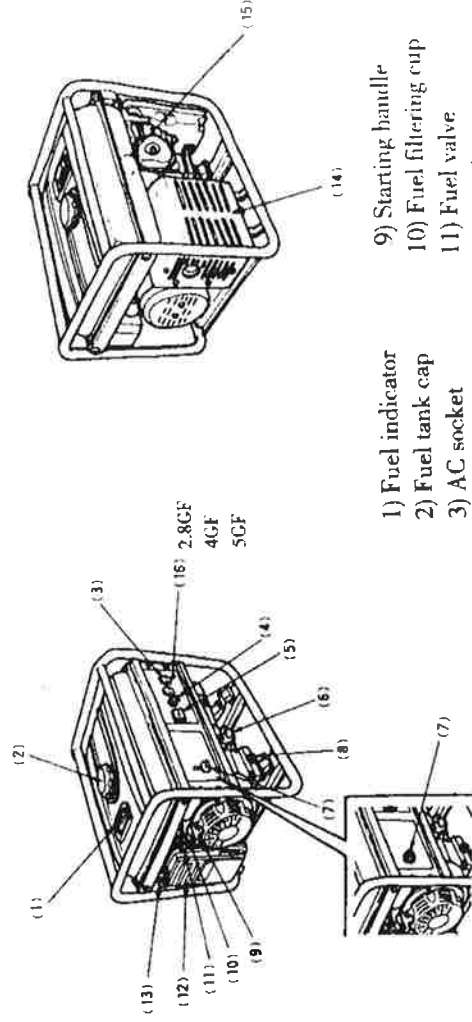

- 1) Fuel indicator
- 2) Fuel tank cap
- 3) AC socket
- 4) AC breaker
- 5) Voltmeter
- 6) Machine oil plug gage
- 7) Engine switch
- 8) Discharging bolt
- 9) Starting handle
- 10) Fuel filtering cup
- 11) Fuel valve
- 12) Air filter
- 13) Choke handle
- 14) Exhaust silencer
- 15) Spark plug
- 16) Grounding terminal

4GFD
5GFD

3. Check-ups before Operation

•Scope of temperature the generator set is applicable for: 150°C to 40°C.

•Scope of humidity the generator is applicable for: Not over 95%

•The generator will output the rated power when running in areas within 1000m above the sea level but lower power than that in areas higher than 1000m above the sea level.

1. Level of machine oil

Caution: Remember that check-ups must be carried out on an even ground with the engine stopped.

A. Insert the oil plug gage into the machine oil filling hole without running and check the oil level.

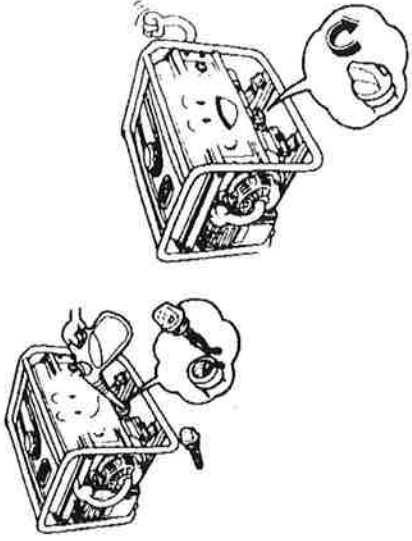
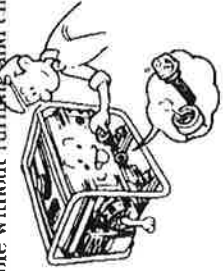

B. When the oil level is too low, refill the machine with machine oil but not over the upper limit mark.

Recommended machine oil:

4-stroke gasoline engine machine oil

Machine oil Class SE or SF of API or SAE10W-30 corresponding to class SG

C. Remount the machine oil plug gage securely.

2. Level of fuel

A. Check the fuel level on the fuel indicator.



B. If the fuel level is too low, screw off the fuel tank cap fill it with fuel to the shoulder of the filter.

Warning: Do not overfill to avoid fuel overflowing.

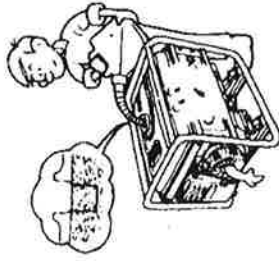

C. Remount the cap.

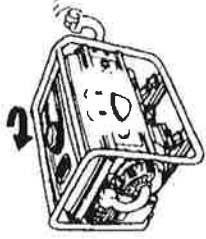

3. Air filter

A. Remove the filter cover.

B. Check the filter element to make sure it is clean and intact.

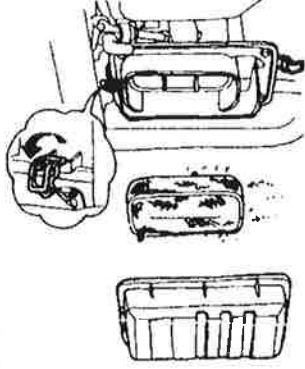

C. If it is dirty, take out the element for cleaning.

- Wash it in solvent.
- Squeeze dry.
- Drop some drips of machine oil into it.
- Squeeze it dry again.

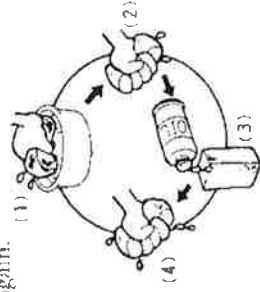

D. Remount the filter element and put the on filter cover.

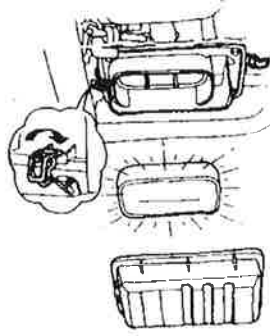

4. Battery (only for Model 4g(i) 5g(i))

Check to make sure that the electrolyte level in every cell is between the upper and lower limit lines.

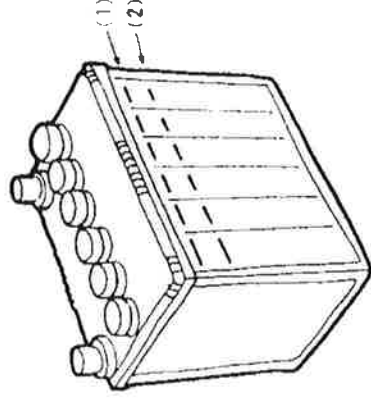

- 1) Upper limit line
- 2) Lower limit line

4. Starting if Generator

Starting with kick starter

1. Remove all loads from the AC output terminal.
2. Turn off the AC circuit breaker.

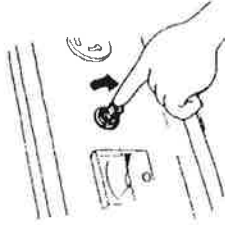

3. Open the fuel valve.



4. Turn the choke handle to "Close" position.

Caution: Do not close the choke when starting a hot engine.



5. Turn on the engine switch.

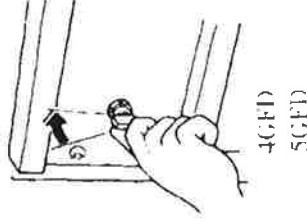
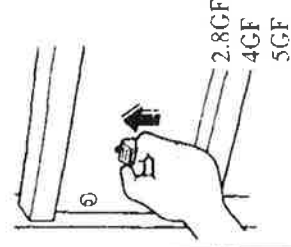

6. Gently hold the starting pull handle till some resistance is felt and then pull it abruptly.

Warning: Never let the starting pull handle retract suddenly but return it gently.

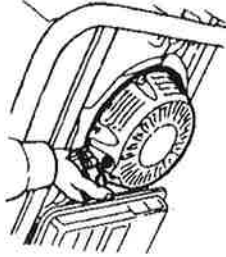

7. When the engine is warmed up, set the choke handle to "Open" position.

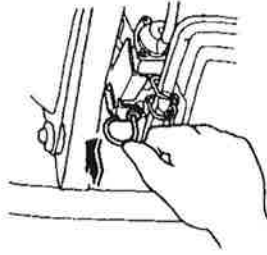

Electric start (only for 4C/FD 5G/FD)

1. Remove all loads from the output terminal.
2. Turn off the AC breaker.

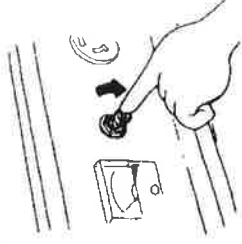

3. Open the fuel valve.



4. Set the choke handle to "Close" position.
Caution: Do not close the choke when starting a hot engine.

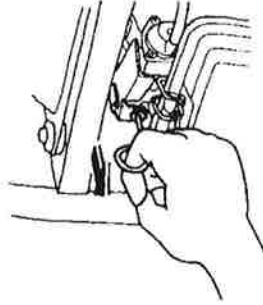

5. Turn on the electric start switch.

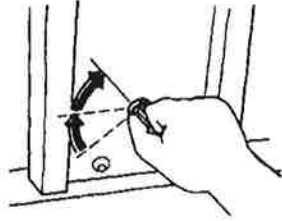

6. Release the electric start switch as soon as the engine is started.

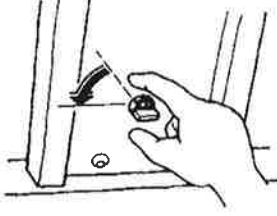

7. When the engine is warmed up, set the choke handle to "Open" position.

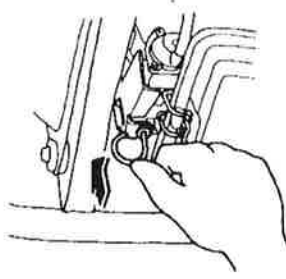

Usage of Generator

To keep the generator in optimal condition mechanically and electrically, the following points shall be observed.

Warning: The generator has to be grounded for fear that any mistakes would be made electrically.

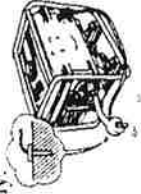

The total power of electric load shall not exceed the rated power of the generator.

Electric appliances: Motor driven devices esp. produce large current on starting.

The following table is for reference to be made when the devices listed below are connected to the generator.

Devices	Watt Value		Typical Device	Example	
	Start	Rated		Device	Start
<ul style="list-style-type: none"> Incandescent lamp Heating device 	x 1	x 1	 TV set	 Incandescent lamp 100W	100VA (W) 100VA (W)
Fluorescent lamp	x 2	x 1.5	 Fluorescent amp Refrigerator Electric fan	 Fluorescent lamp 40W	80VA (W) 80VA (W)
Motorized device	x 1.5	x 2		 Refrigerator 150W	450~750VA (W) 300VA (W)

When two or more loads are to be connected to the generator, they shall be connected from the one requiring larger current to that requiring a small one.

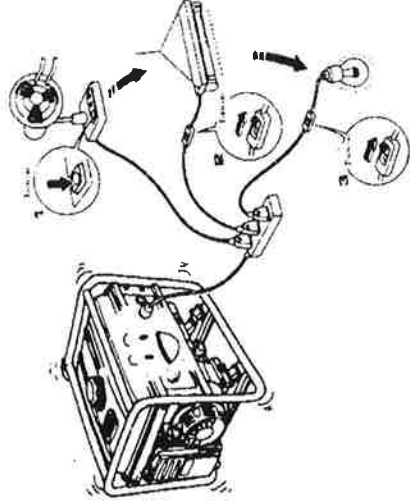

Note:

If the generator is to be wired for house power supply, wiring shall be carried out by an electrician.

Check to make sure that the wiring is correct. Wrong wiring will cause damage to the generator and even a fire.

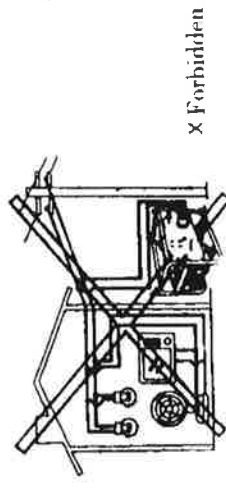
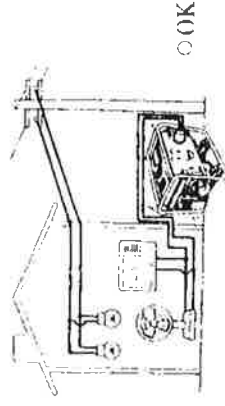

OK

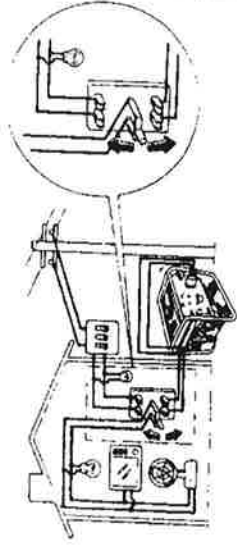

Use of AC

1. Starting the engine
2. Ensuring that the voltmeter indicates voltage.
3. Connecting devices

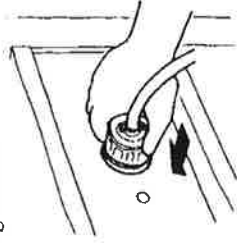

4. Connecting the AC breaker

Note: Overcurrent will automatically turn off the AC breaker. When that is turned off, the generator shall be restarted with load reduced a few minutes thereafter.

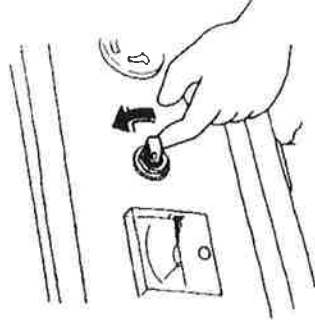

6. Stopping of Generator

1. Turn off the AC breaker.

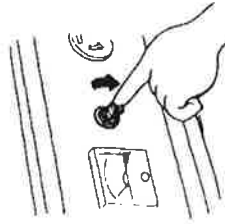

2. Turn off the engine switch.

2.8GF
4GF
5GF

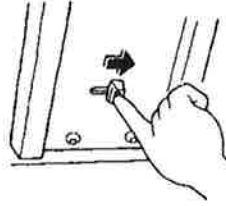

4GFD
5GFD

























3. Remove all loads.
4. Close the fuel valve.



Note: When an emergent stop of the engine is needed, turn the generator switch of "OFF" position.

7. Maintenance

- Check-up
- Replacement
- Cleaning
- Check & readjustment

			Or in the last month of operation	Or at an interval of 3 months	Or at an interval of 6 months	Or at an interval of 1 year	Refer to Page
Check-up of machine oil							P.6
Replacing machine oil							P.14
Check-up of air filter							P.4
Washing air filter							P.5
Fuel filtering cup							P.15
Electrolyte level of battery							P.5
Spark plug							P.14
Air valve gap							-
Washing cylinder head							-
Washing fuel tank							-

Note: "※": These items shall be assisted by the special Loncin agent in maintenance.

1. Replacing machine oil

1. Open the filling hole.
2. Remove the oil discharging bolt and drain off the used oil.

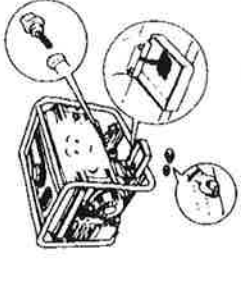

3. Remount the oil discharging bolt tightly.
4. Fill the machine with fresh oil and check the oil level. Its machine oil capacity is 1.1L.
5. Remount the oil plug gage.

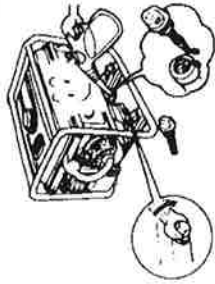

2. Spark plug

1. Remove the spark plug cap.
2. Remove the spark plug.

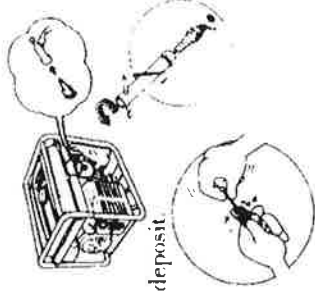

3. Remove carbon deposit.

4. Check the spark plug gap.

Model of standard spark plug:
BPR5FS, BPR5FS (NGK), W16EPR-U, W16EPR-U (DENSO)

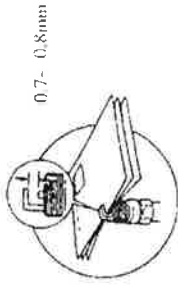

0.7- 0.8mm

5. Remount the spark plug and its cap.

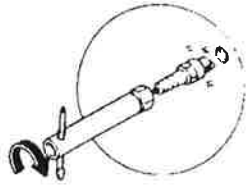

3. Clean the cup and screen.
4. Remount the cup and screen.

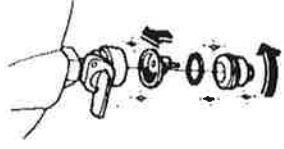

3. Fuel filtering cup

1. Close the fuel valve.
2. Remove the settling cup and straining screen.

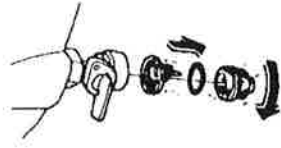

8. Storage

1. Drain off fuel from the fuel tank.
2. Clean and then remount the straining screen and settling cup.
3. Drain off fuel from the carburetor.
4. Screw off the machine oil plug gage & discharge bolt and then drain off oil.

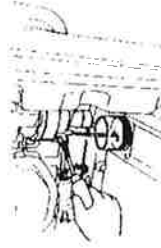

3. Drain off fuel from the carburetor.

4. Screw off the machine oil plug gage & discharge bolt and then drain off oil.

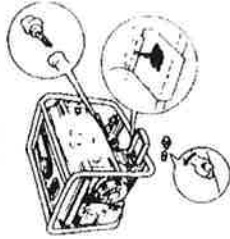

5. Remount the discharge bolt tightly, fill the machine with fresh machine oil to the upper limit mark and then remount the gage.

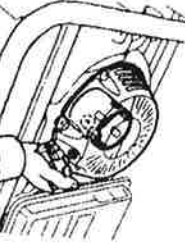
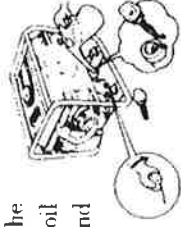

6. Gently pull the start pull handle till some resistance is felt.

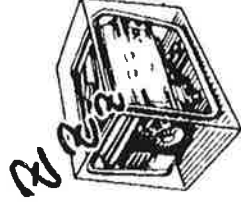

7. Place the generator in a clean area.

9. Troubleshooting

The engine can not start:

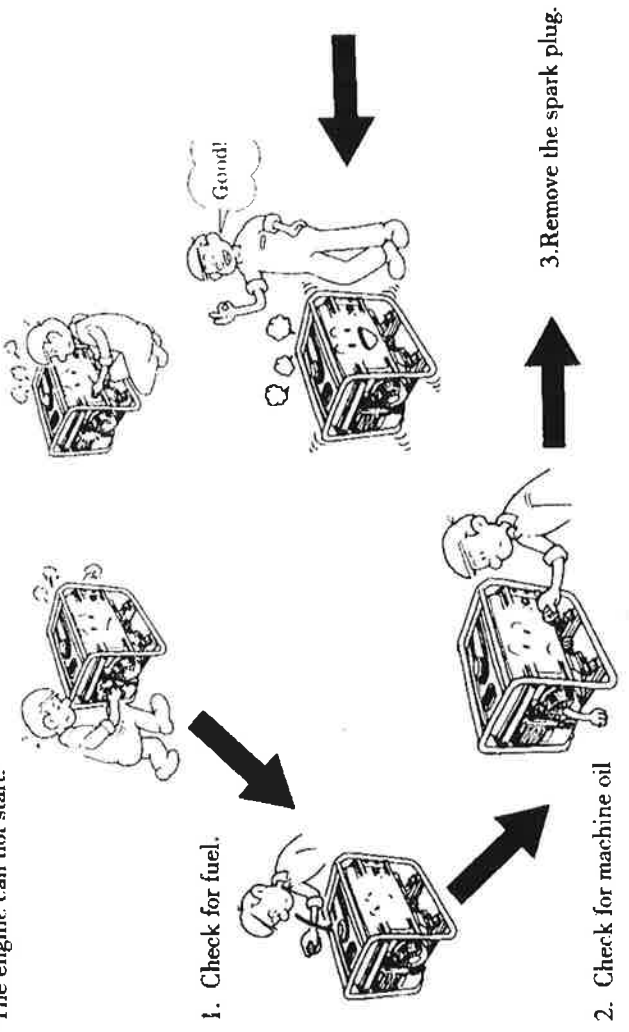

There is no voltage?

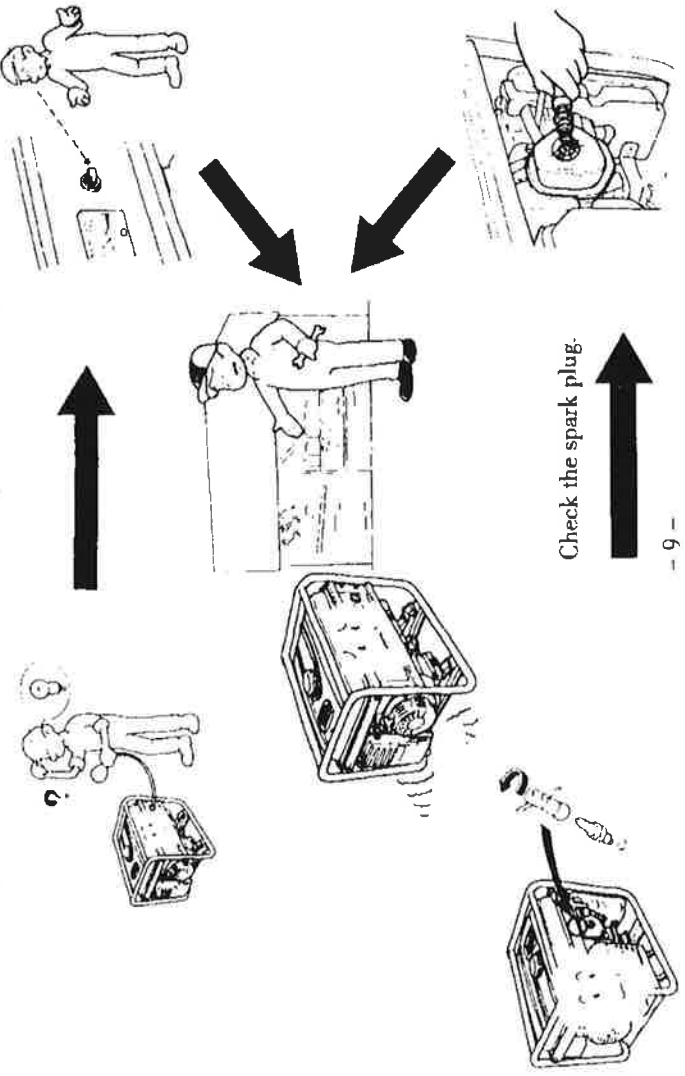

10. Technical Data

Model	2.8GF	4GF/4GFD	5GF	5C(FD)
Whole unit				
L x W x H(mm)	680 x 510 x 540	680 x 510 x 540/655 x 510 x 540	680 x 510 x 540	855 x 510 x 540
Net weight (without fuel)	68Kg	80Kg / 87Kg	83Kg	90Kg
Model	LC173F	LC182F(D)	LC188FD	
Type	4-stroke single cylinder,overhead valve type			
Displacement(cm ₃)	242	337	389	
Bore x stroke(mm)	73 x 58	82 x 64	88 x 64	
Cooling system	Forced air cooling			
Ignition system	Transistor,magnetic iron ignition type			
Spark plug	BP5ES,BPR5ES(NCK),W16EP-U,W16EPR-U(DENSO)			
Volume of machine oil	1.1L			
Capacity of fuel tank	25L			
Compression ratio	8.2:1	8.0:1	8.0:1	
Model	LC2.8GF	LC4GF(D)	LC5GF	LC5GFD
Rated voltage(V)	220V			
Rated frequency(Hz)	50Hz			
Rated current	12.7A	18.2A	22.7A	
Rated output power(KVA)	2800VA	4000VA	5000VA	
Max.output power(KVA)	3100VA	4500VA	5500VA	
Generator				

11. Battery Unit

1. Mount the battery unit reliably in position with bolts,nuts and washers.
2. Get the electric start cable through under the tank and connect it to the solenoid.
3. Connect the grounding wire to the rear end of the generator.

4. Connect the electric start cable to the positive pole first and then to the negative one.To disconnect them,first remove the negative and then the positive pole.

- 1). Starting solenoid switch
- 2). Electric start cable
- 3). Battery protective barrier
- 4). Battery holder
- 5). Battery protective plate
- 6). Battery hold-down device
- 7). Battery (to be of 12V-35Amp hr min.)
- 8). Cable

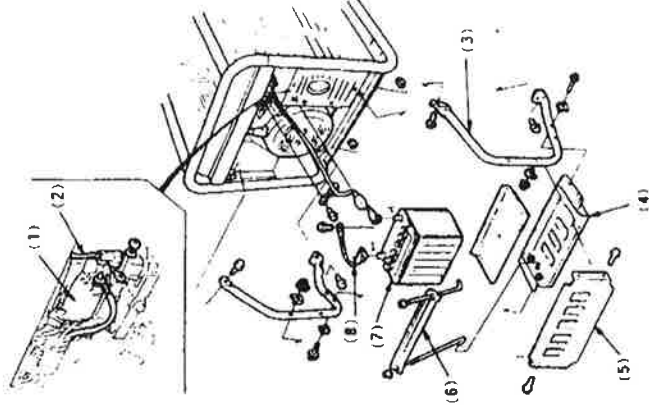

12. Wheel unit

1. Fix the four wheels to the axle by washers and pins.
2. Fix the wheel axle to the generator by bolts and nuts.

- 1) Internal side
- 2) Shorter side
- 3) Longer side
- 4) Wheel lock pin
- 5) Lock disc
- 6) Engine side
- 7) Washer
- 8) Pin
- 9) Wheel
- 10) Axle (on engine side)
- 11) Axle (on generator side)
- 12) Bolt
- 13) Nut

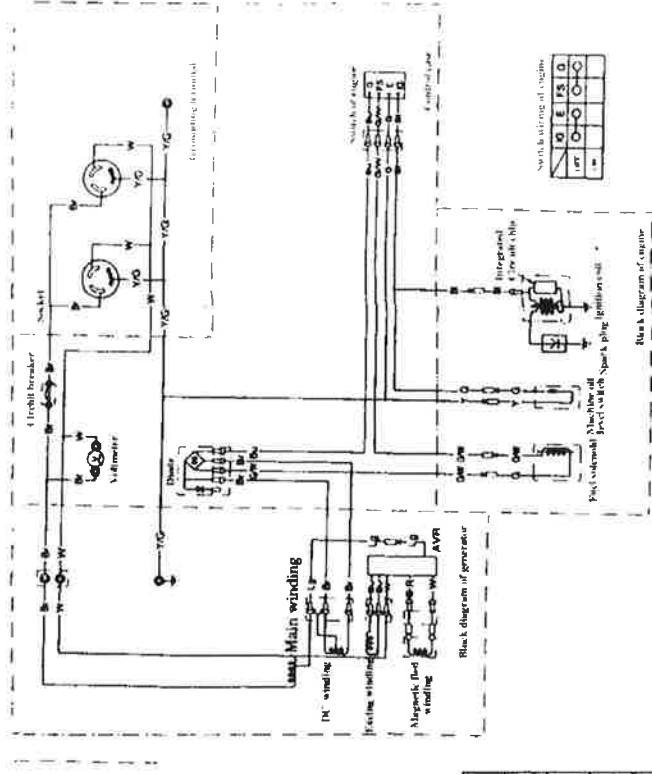
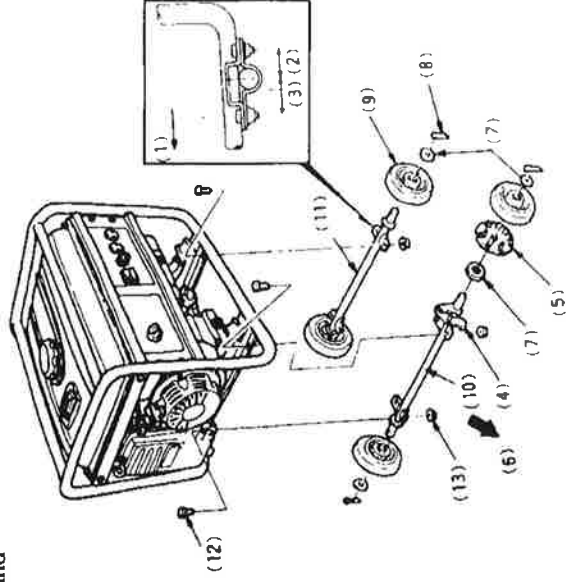

2.8GF/4GF

Bl	Black	Br	Brown
Y	Yellow	o	Orange
Bu	Blue	Lh	Light blue
C	Green	Lg	Light green
R	Red	P	Pink
W	White	Gr	Grey

5CF

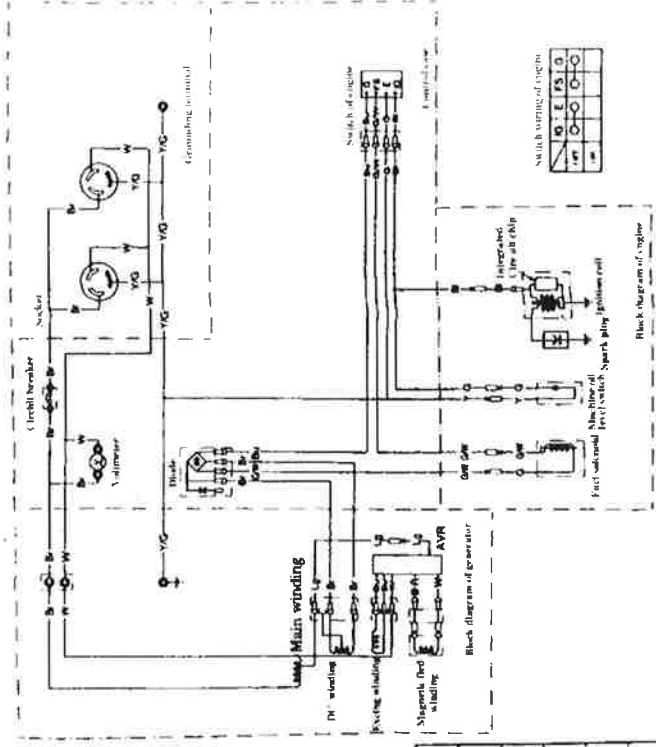

Bl	Black	Br	Brown
Y	Yellow	o	Orange
Bu	Blue	Lb	Light blue
C	Green	Lg	Light green
R	Red	P	Pink
W	White	Gr	Grey

10	11	12	13	14	15	16
17	18	19	20	21	22	23

4GFD
5GFD

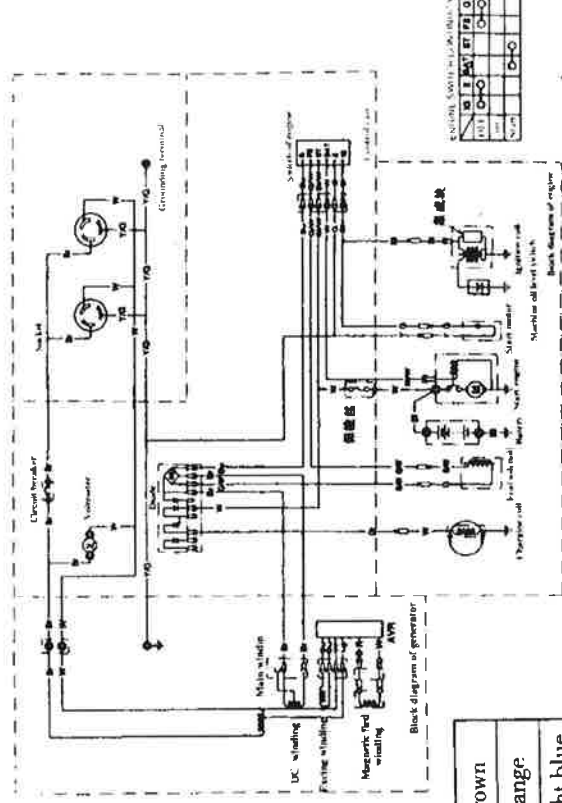

Bl	Black	Br	Brown
Y	Yellow	o	Orange
Bu	Blue	Lb	Light blue
C	Green	Lg	Light green
R	Red	P	Pink
W	White	Gr	Grey

10	11	12	13	14	15	16
17	18	19	20	21	22	23