

ORIGINAL INSTRUCTIONS

# FEIDER

## MACHINES

### PETROL ROLLER MOWER OWNER'S MANUAL FTDTR4240 /FTDTR4240ES

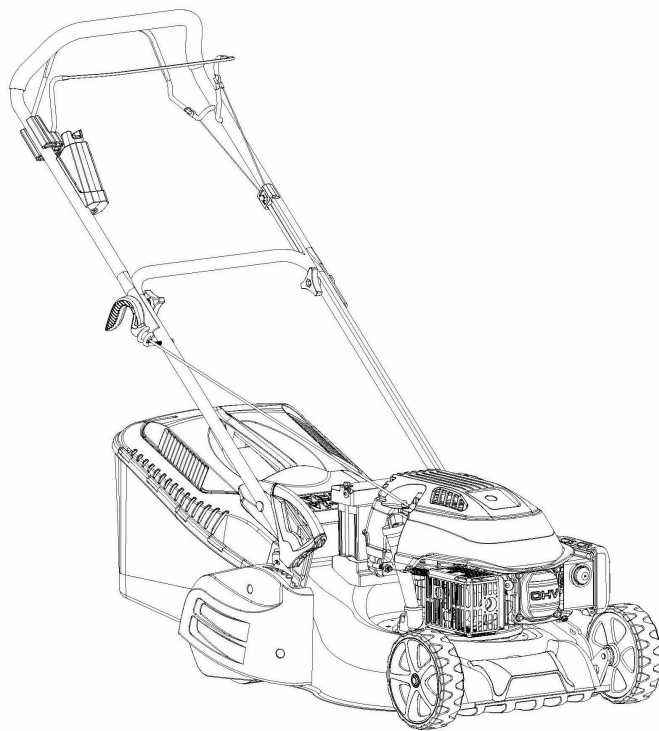

**CAUTION:** Read and follow all Safety Rules and Instructions before operating this equipment

**BUILDER SAS**  
32, rue Aristide Bergès - ZI 31270 Cugnaux - France  
MADE IN PRC

## 1. SAFETY INSTRUCTIONS

---

### Instructions

- Read the instructions carefully. Be familiar with the controls and proper use of the equipment.
- Never allow children to use this mower. If the mower is given to another person, also give this manual. Also make sure that this person uses this device only after receiving the necessary instructions. Local laws may restrict the age of the user.
- Never mow while people, especially children, or animals are nearby.
- Keep in mind that the operator or user is responsible for accidents or risks that may occur to other persons or their properties.
- If necessary, have training with an experienced person in order to use in a safe way this tool.

### Preparation

- During mowing, always wear slip-resistant foot protection and long pants. Do not use the equipment barefoot or wearing sandals open.
- Wear personal protective equipment including at least: clothes of protection, gloves, foot protection, mask, ocular and hearing protection
- Carefully inspect the area where equipment and remove all foreign objects such as stones, toys, sticks and wires.
- **WARNING** - Gasoline is extremely flammable.
  - Add fuel before starting. Do not remove the fuel tank cap while the machine is running or when it is hot.
  - If the fuel has spilled or leaked, do not attempt to start the machine but move the machine away from the leakage area and avoid creating a source of ignition until the gasoline vapours have dissipated.
  - Refuel only outside and do not smoke during refuelling.
  - Store fuel in tanks specifically designated for this purpose.
  - Replace the fuel tank or the defective gasoline plug securely.
- Replace defective mufflers.
- Before use, always inspect visually that the blades, blade assembly and blade lock are not worn or damaged. Replace blades and blade assemblies that are not in good condition to maintain balance. Always use recommended blades. Contact the manufacturer or your dealer in order to have a list of recommended blades. Non-recommended blades can give a risk of malfunctions, injuries and accidents.
- The blades must be balanced to ensure proper operation and to be able to work safely.

### Operation

- Do not use the machine in a confined space or hazardous carbon monoxide emissions can be collected.
- Mow only under daylight or under good artificial light. Always have a good visibility.
- Avoid using the equipment on greasy grass, where possible.
- Always be sure of your walking on the slopes.

- Walk, never run.
- For lawn mowers, mow across slopes, never from top to bottom.
- Exercise extreme caution when changing direction on slopes.
- Stop the blades if the mower is to be tilted during transport when crossing surfaces other than grass, and when transporting the mower due to the area to be mowed.
- Do not mow on steep slopes.
- Use extreme caution when tipping or pulling the mower towards you.
- Never use the mower with defective guards, or without safety devices such as baffles and or collection bins, which are not in place.
- Do not change the motor configuration or increase the speed.
- For starting, disengage all blades, the gears must be in neutral, the traction control lever must be released. Set foot well away from the blades.
- Before starting the engine or starting the engine, carefully read and understand all instructions.
- Do not tilt the mower when starting the machine or turn on the engine, unless the mower needs to be tilted for starting. In this case, do not tilt it more than absolutely necessary and lift only the part that is furthest away from the user.
- Do not start the machine by standing in front of the ejection
- Do not place hands or feet near or under rotating parts. Keep clean the mouth of the grass extractor.
- Never take or carry the mower while the machine is running.
- Stop the machine and remove the ignition key, disconnect the spark plug from the spark plug:
  - Before cleaning or unclogging the grass extractor.
  - Before checking, cleaning, and working on the mower.
  - After hitting an object. Inspect the mower for damage and repair before re-using the mower.
  - If the mower begins to vibrate abnormally, stop the engine immediately and check according to previous recommendations.
- The controls must be always checked if they are functioning correctly. In case of malfunction, do not use the tool and bring to a service agent for inspection.
- Stop the engine immediately:
  - Every time you leave the tool alone and the working area
  - Before refuelling.
- When the tool is stopped, park it in a safe place.
- Move slowly when moving.
- The lawnmower should not be used in slopes and near drop-offs, ditches or embankments; if the tool must be used in these kinds of emplacements, take an extreme precaution and operate carefully the tool.
- The lawnmower safety systems or features shall not be tampered with or disabled;
- The operator should not alter or tamper with any sealed adjustments for the engine speed control.

**Maintenance and storage**

- Check and tighten all bolts and screws to ensure that the equipment is in safe operating condition.
- Never keep the mower with gasoline in the tank in a building or vapours can cause a bright flame or spark.
- Allow the machine to cool before storing it in an enclosed area.
- To reduce the risk of fire, keep the machine clean without grass, without grease, the muffler and the engine cools, disconnect the battery if necessary and empty the fuel tank
- Check the grass catcher frequently, its condition or deterioration.
- Replace worn and damaged parts for safety.
- If the fuel tank is to be drained, it must be made outdoors.

**Special safety instructions**

- Always use the mower with its pick-up bag and / or deflector in the intended position.
- Switch off the engine before emptying the pick-up bag or before changing the cutting height.
- While the engine is running, never put your hands or feet under the mower or under the grass ejection area.
- Before mowing, remove all foreign objects from the grass that can be propelled by the machine.
- Keep children and pets at a safe distance while using the mower.
- Never lift the mower when the engine starts.
- Alcohol, drug, as well as illness, fever and fatigue affect your ability to respond. Do not use power tools in such circumstances.
- Never change the rated speed of the motor.
- Never lift or carry the tool while the engine is running.
- Before starting the engine, release the drawbar.
- Before mowing, install the collection bag in its intended position.
- Do not use the mower in the event of rain or when the grass is wet.
- Never lift the rear of the mower when starting the engine and never place your hands or feet under the mower deck or in the rear ejection port while the engine is running.
- Turn off the engine and remove the spark plug cap in the following cases:
  - Before operating under the mower deck or near the ejection opening.
  - Before any maintenance, repair or verification.
  - Before transporting, lifting or storing the mower.
  - If you leave the mower unattended or change the cutting height.
  - To remove and empty the collection bag.
- After striking a foreign object, turn off the engine and carefully inspect the mower for damage. Take the lawnmower to an authorized service center for repair if necessary.
- If the mower vibrates abnormally, try to understand the reason and bring your lawnmower to an authorized repair center.
- Regularly check that the bolts, nuts and screws are properly tightened for safe use of the mower.
- Do not use the tool where there is a risk of lighting.

## ORIGINAL INSTRUCTIONS

- Use the tool on daylight or under a good lighting. Always keep bystanders away.
- Warning: Take an extreme precaution when operating the lawnmower in slopes and near drop-offs, ditches or embankments; always be sure of your footing and stay in alert.
- the lawnmower safety systems or features shall not be tampered with or disabled;
- the operator should not alter or tamper with any sealed adjustments for the engine speed control;
- The operator must have, before using the tool for the first time, an adequate training with an experienced people.
- Warning: do not use of the unit while being tired, ill or under influence of alcohol or other drugs;
- Park safely the tool before leave it. The tool must be switched off.
- The lawnmower shall not be operated without either the entire grass catcher or self-closing discharge opening guard in place;
- Warning: be careful about exhaust gas. Do not inhale them.
- Wear adequate clothing such as long trousers and a protective equipment: slip-resistant foot protection, hearing protection, eyes protection and gloves.
- To avoid health issues, limit the time of operation. Take enough rest. Exposure to noise and vibrate can have bas consequences on health.
- WARNING: There is a danger about moving blade assemblies. Always handle blades when they are in a complete stop and wear protective gloves.

### **Fuel Handling**

Use caution when handling fuels. They are flammable and the vapours are explosive.

Use only an approved container.

Never remove the fuel cap or add fuel while the machine is on. Turn off the unit and allow the engine and exhaust components to cool down before refuelling.

Do not smoke.

Never refuel inside a room.

Never store the tool and the fuel tank indoors where there is a naked flame, such as near a water heater.

If fuel has spilled, do not attempt to start the machine, but move it away from the spill before starting to use it. Please clean up any spills.

Replace and tighten the fuel tank cap after refuelling.

Follow strictly the instructions in this manual for filling the tool with fuel.

### **During maintenance and storage**

Switch off the tool and wait until it stops completely. Make sure that all moving parts are stopped.

Allow the machine to cool before performing inspection, adjustments, maintenance, servicing and storage.

Store the tool where fuel vapour will not reach a flame or spark.

The transport of the tool must be secured in order to avoid fuel spillage, accidents and injuries.

**Residual risks**

Even if you use this product in compliance with all safety requirements, the potential risks of injury and damage remain. The following hazards may arise in the structure and design of this product:

There are risks of injury and property damage due to attachments or broken the sudden impact of hidden objects when using cutting.

There are risks of injuries and accidents caused by flying objects.





Prolonged use of this product exposes the operator to vibrations and can produce so-called "white finger" disease. To reduce the risk, wear gloves and keep your hands warm.







If any of the symptoms of "white finger syndrome" occur, seek immediate medical attention.

Symptoms of "white finger" include numbness, loss of sensitivity, tingling, pain, loss of strength, colour changes or skin condition. These symptoms usually appear on the fingers, hands or wrists. Risk increases at low temperatures.

A long exposition to noise can affect the health of the operator. A hearing protection must be always used when operating the tool. The operation of the tool must be limited and some rest must be taken between two sessions (e.g. 10min of operation and 20min of rest).

**Symbols**

	<p>Read the instructions</p>
	<p>Watch out for projections! Keep viewers away from work area</p>
	<p>Danger! Keep your hands and feet away from the cutting element</p>
	<p>Warning – Exhaust gas. Do not be exposed to exhausted gas and do not use the tool in a confined place</p>

	<p>Fuel is flammable, keep it away from fire. Do not add fuel while the machine is running</p>
	<p>During repair work, remove the spark plug and repair according to the operating manual</p>
	<p>Wear protective equipment. Wear eye and hearing protection when using the tool</p>
	<p>Warning – The engine is hot during the use</p>
	<p>Guarantee sound power level</p>
	<p>Do not use the machine in the rain and do not leave it outside when it rains.</p> <p>Wait until all machine components have come to a complete stop before touching them. The blades continue to rotate after the machine has stopped, a rotating blade can cause injury.</p>

**Intended use**

This model of thermal mower is designed for mowing natural grass. Any other use is prohibited.

It is only suitable for private use in a garden or a plot. Lawn mowers designed for private plots or gardens are those used for the maintenance of grassy areas and private turf and should not be used in public areas, parks, sports, agricultural or forestry areas.

2. DESCRIPTION

---

a. Product

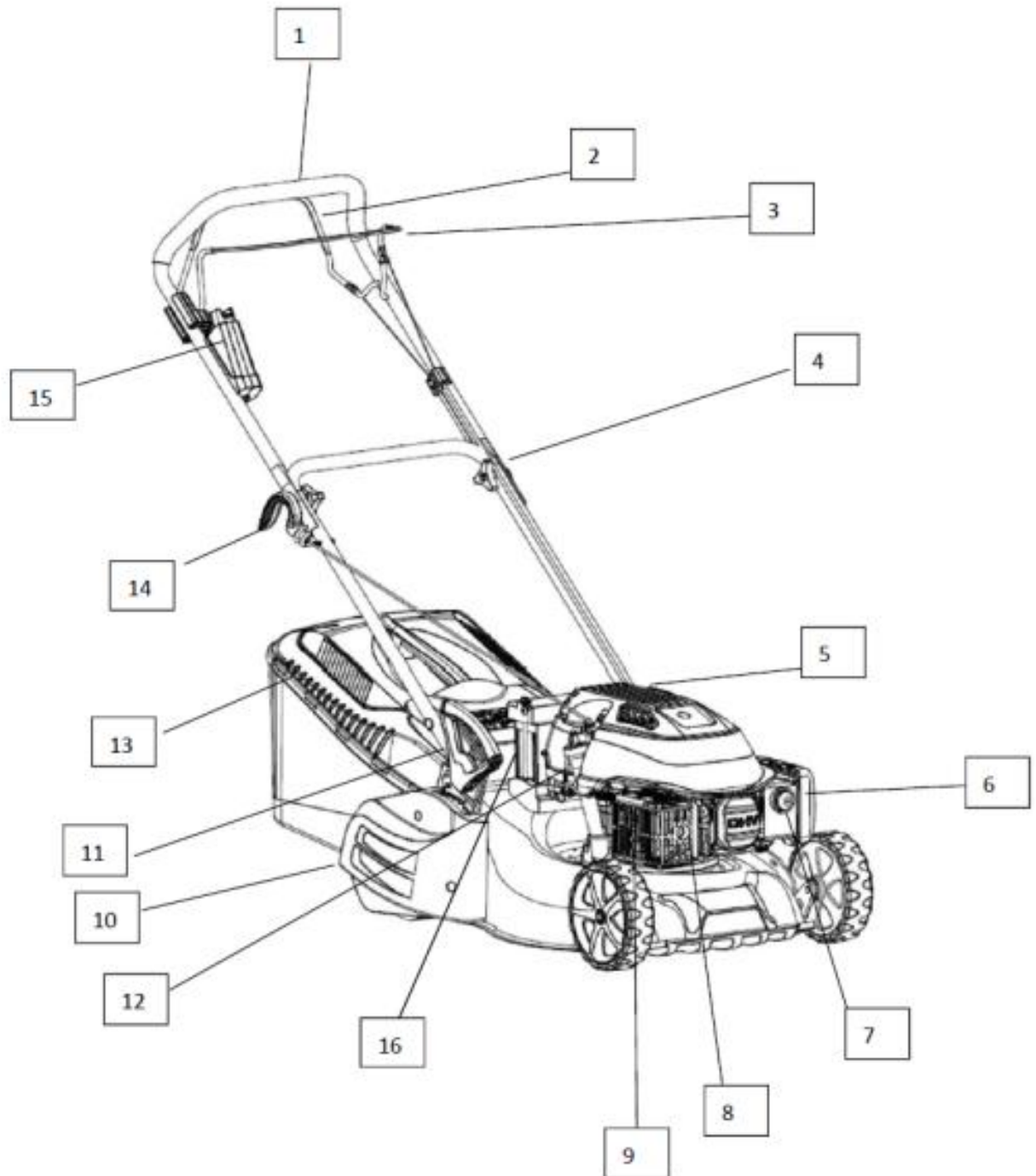



- 1 - Handle
- 2 - Drive Control (Self Propelled) Lever
- 3 - OPC (Operator Presence Control) Lever
- 4 - Knob
- 5 - Fuel Filler Cap
- 6 - Air Filter
- 7 - Primer Bulb (If Applicable)
- 8 - Spark Plug
- 9 - Exhaust
- 10 - Rear Roller
- 11 - Cutting Height Adjustment Lever
- 12 - Oil Filler Cap
- 13 - Grass Collector
- 14 - Recoil Starter Handle
- 15 - Electric start button (only for model FTDTR4240ES)
- 16.-Battery (only for model FTDTR4240ES)

#### b. Technical data

	<b>FTDTR4240</b>	<b>FTDTR4240ES</b>
<b>nominal power</b>	2,6 kW	2,6 kW
<b>Cutting width</b>	420 mm	420 mm
<b>speed</b>	2800/min	2800/min
<b>sound power level</b>	L <sub>WA</sub> = 93.97dB(A) K=1.75 dB(A)	L <sub>WA</sub> = 93.97dB(A) K=1.75 dB(A)
<b>sound pressure level</b>	L <sub>pA</sub> = 82.1 dB(A). K=2.5dB(A)	L <sub>pA</sub> = 82.1 dB(A). K=2.5dB(A)
<b>guaranteed sound power level</b>	96 dB(A)	96 dB(A)
<b>vibration</b>	5.361m/s <sup>2</sup> K=1.5m/s <sup>2</sup>	5.361m/s <sup>2</sup> K=1.5m/s <sup>2</sup>
<b>machine mass</b>	30,8 kg	33,8 kg

### 3. ASSEMBLY

---

#### Handle Setup and Height Adjustment

Screw the lower bar to the tool with the two nuts and Bolts and with 2 knobs and bolts (in the adjustment height location)

Screw the upper bar on the lower bar with the four knobs and bolts.

Put the recoil starter on the right of the handle and fix the cable with the plastic collar.

Introduce the rope of the recoil starter handle on its support guide rope.

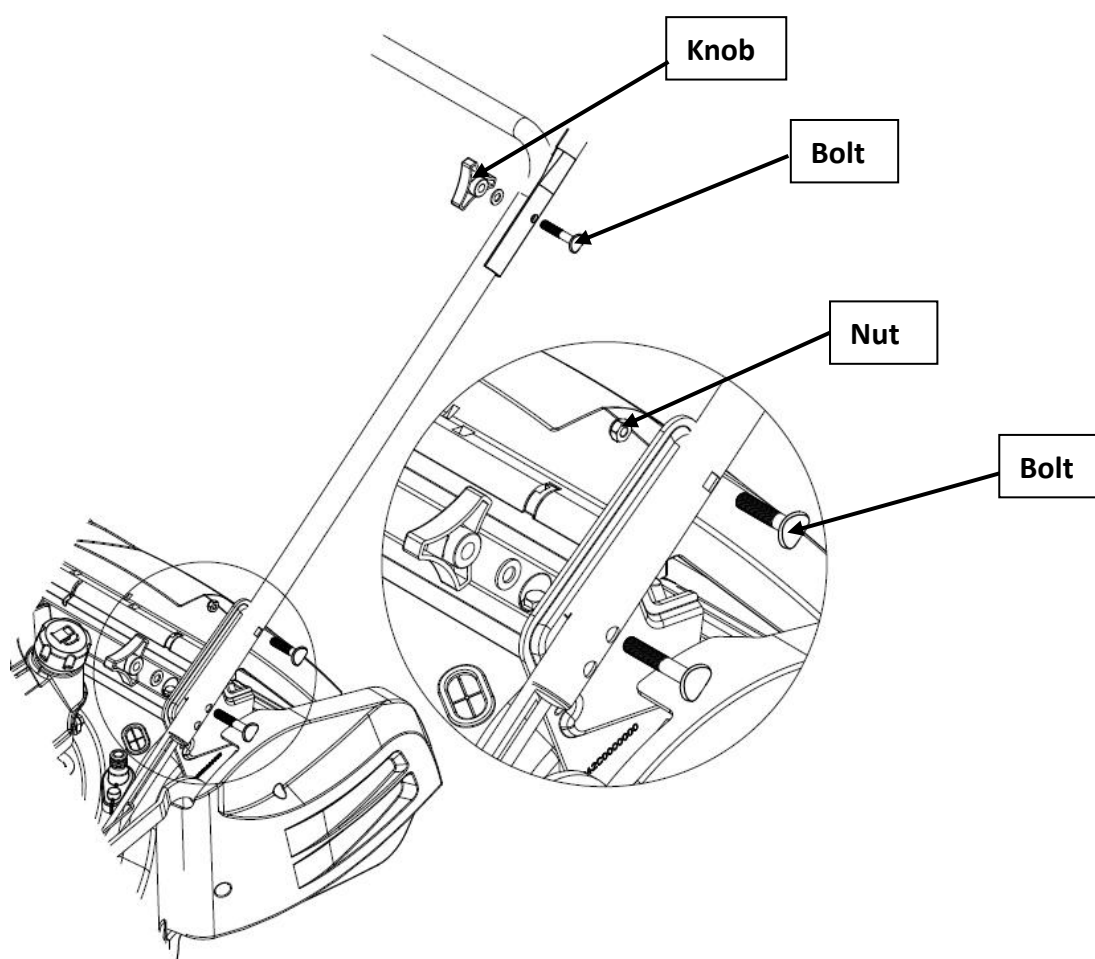

If you want to adjust height of the handle bar, you can choose "L" or "H" two holes in left-right Bracket to fix the handle bar with screws and knobs.

The "H" hole is high position of the handle bar, and the "L" hole is low position of the handle bar.

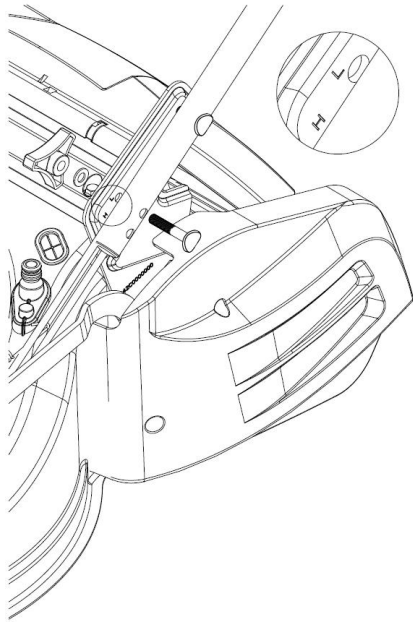

**Brake Cable Setup**

Put the brake cable and Clutch cable to the hole of brake lever and Clutch lever. (see the arrow mark)

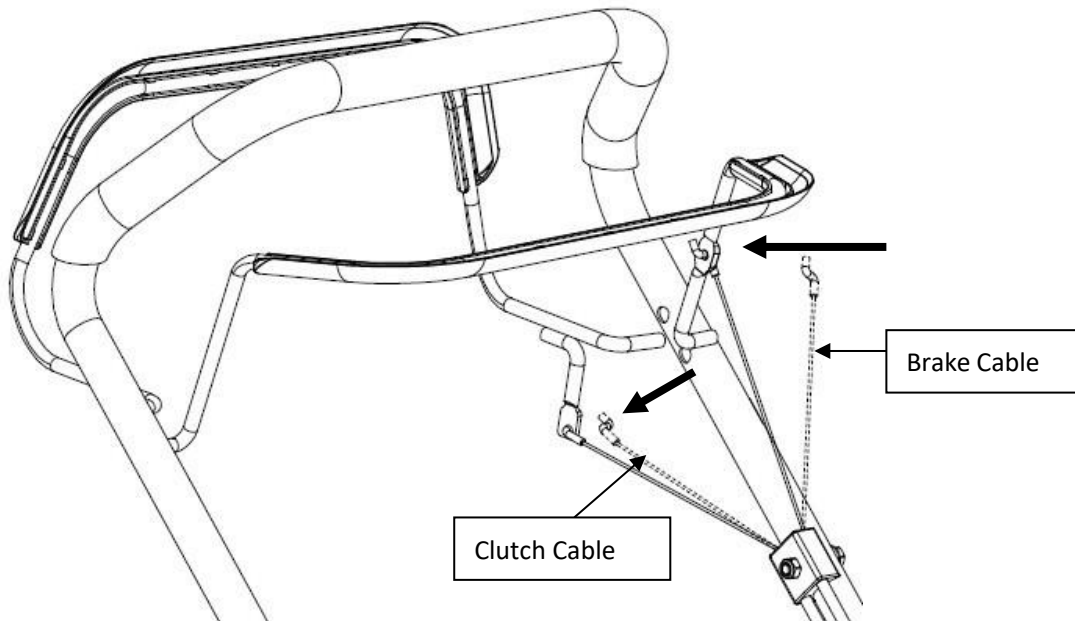

**Grass catcher**

- Lift the rear discharge guard and install the grass bag.

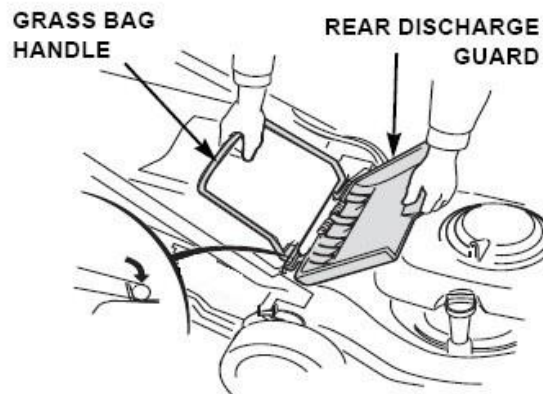

To remove the grass bag, lift the rear discharge guard and remove the grass bag.

## 4. FILLING FUEL AND OIL TANK

### A) Filling tank

**WARNING! Gasoline is extremely flammable.**

Store fuel in specially designed cans for this purpose.

Fill the fuel tank only outdoors and before starting the engine. Do not smoke when filling the fuel tank or handling fuel.

Never open the fuel tank cap and never add fuel while the engine is running or when it is hot.

If fuel has spilled, do not start the engine any further, move the tool away from where the fuel has been spilled, and be careful not to create a spark or flame until the fuel vapors have dissipated.

Fully close all fuel tank and fuel canisters.

Before tilting the mower to maintain the blade or drain the oil, empty the fuel tank.

**WARNING:** Never fill the fuel tank indoors, while the engine is running, or before the engine has cooled down for at least 15 minutes after use.

**CAUTION:** Do not use unapproved gasoline, such as E15 and E85. Do not mix the oil with gasoline or modify the engine to operate with alternative fuels. The use of unapproved fuels will damage the engine parts and will void the engine warranty. To protect the fuel system from scale formation, add a fuel stabilizer to the fuel. All fuels are not identical. If startup or performance problems occur, change supplier or fuel brand.

Fuel must meet the following criteria:

- Clean, new and lead-free gasoline.
- A minimum octane rating of 87/87 AKI (91 RON).
- A gasoline containing up to 10% ethanol is acceptable.
- Remove the fuel tank cap. Add fuel.
- Close the fuel tank with the cap.

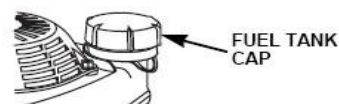
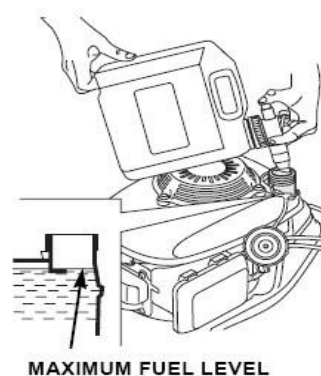

**Do not overfill. Wipe off any fuel that has overflowed before starting the engine.**

a. **Engine oil**

Recommended oil: We recommend the use of high quality detergent oil classified for SF, SG, SH, SJ or higher. Do not use special additives.

Filling oil tank

- Open the oil tank.
- Fill directly the oil in the tank. Do not overfill
  - Close the oil tank. Wipe any spillage.

Checking the oil level

- Check the oil level when the engine is off and horizontal.
- Remove the plug / dipstick from the oil tank and wipe it off.
- Insert the oil tank plug / dipstick into the tank neck as shown, without screwing it in, and then remove it to check the oil level.
- If the oil level is near or below the lower limit of the dipstick, remove the dipstick and fill the recommended oil reservoir up to the upper limit of the dipstick (bottom edge of the dipstick). Do not overfill.
- Replace the oil tank plug / dipstick.

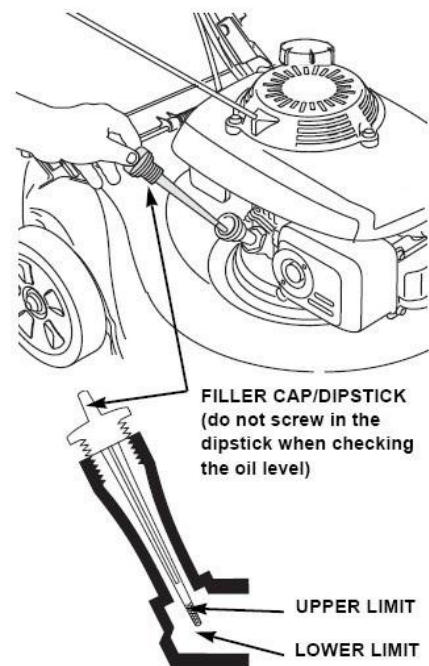

**Charge The Battery (only for the model FTDR4240ES)**

Charge the battery before use the electric start function is used, the battery must be charged for 5 hours. Put the charger plug into the hole in the battery and connect the charger to a power supply.

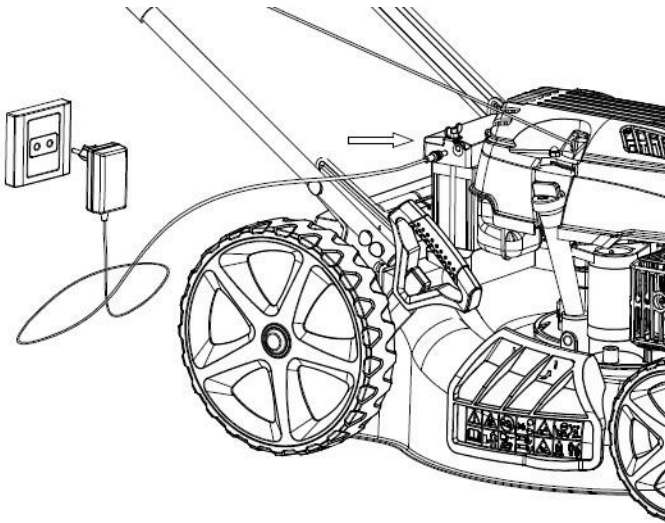

**Cutting Height Adjustment**

To set the cutting height, pull the cutting height lever and push it backward or forward to adjust the cutting height.

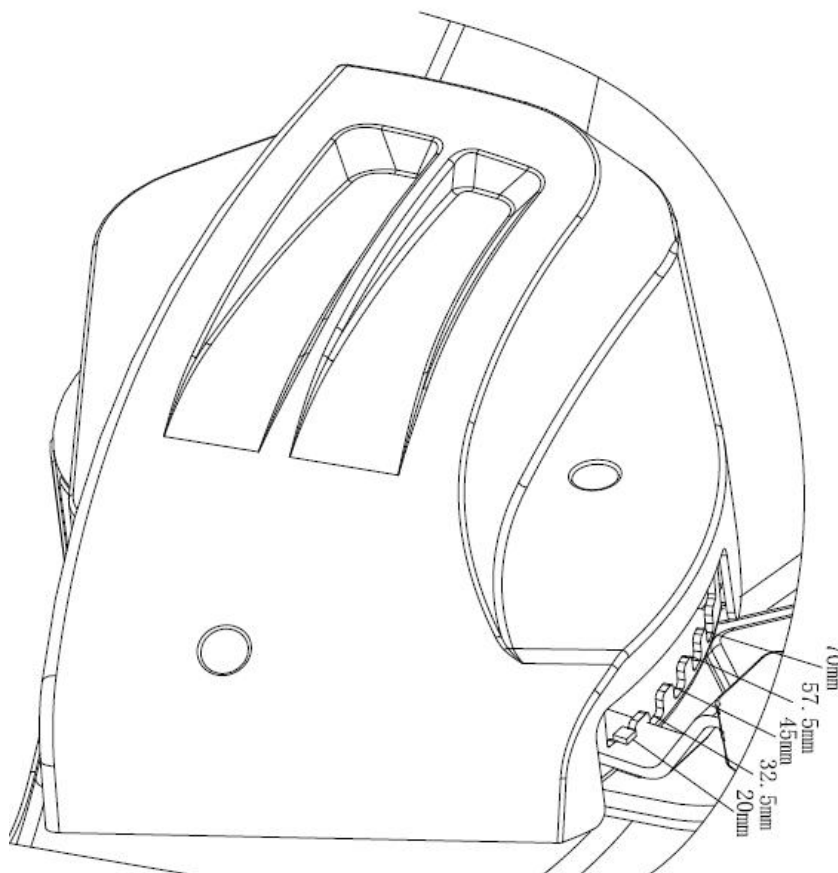

**WARNING**

The blade can cause serious injury. Stop the engine before adjusting cutting height.

## 5. OPERATION

---

### FOR MODEL FTDTR4240

#### a) Starting the engine

- Place the mower in a clear, level area.
- Push the primer bulb several times (at least 8 times).
- Pull back on the operator control lever and hold it against the handle (the clutch lever must not be activated)
- With the starter handle in its support, take the starter handle with your right hand and pull slowly as far as to have a resistance, and then pull energetically on the starter handle with starter rope through the support.

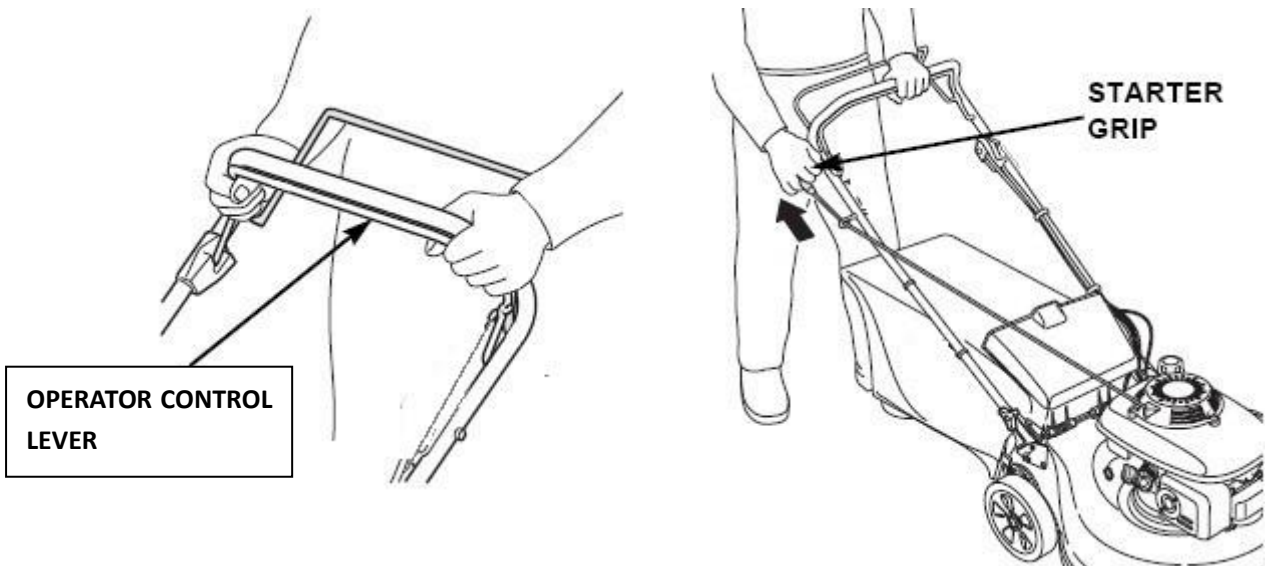

### FOR MODEL FTDTR4240ES

#### a) Starting the engine

##### Manually

- Place the mower in a clear, level area.
- Push the primer bulb several times (at least 8 times).
- Pull back on the operator control lever and hold it against the handle (the clutch lever must not be activated)
- With the starter handle in its support, take the starter handle with your right hand and pull slowly as far as to have a resistance, and then pull energetically on the starter handle with starter rope through the support.



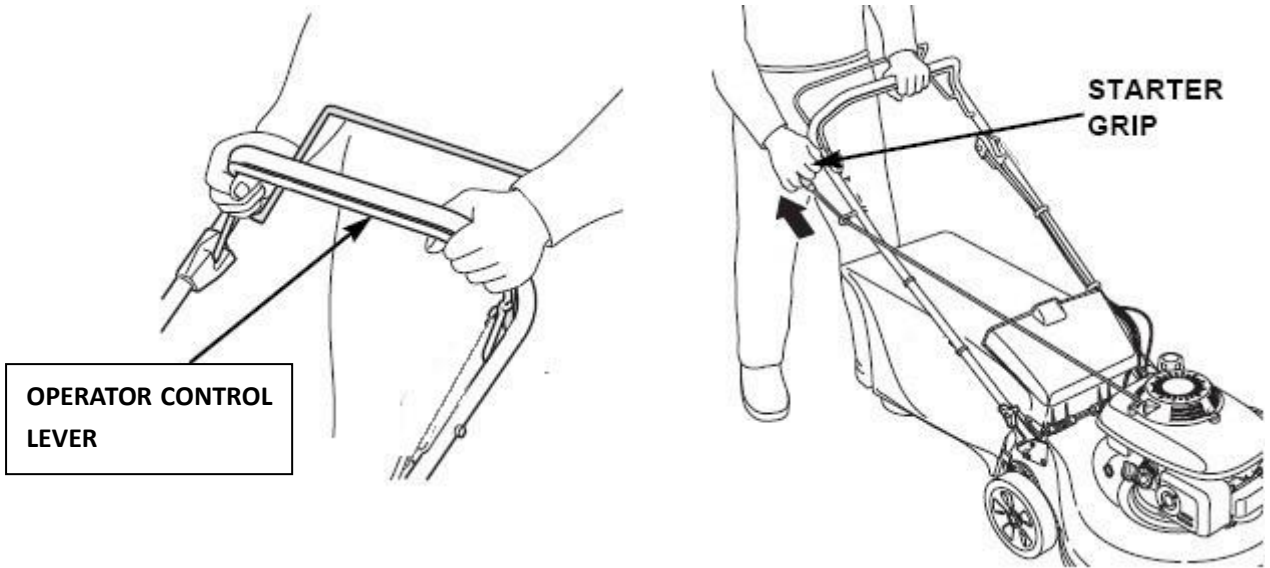

**Electrically**

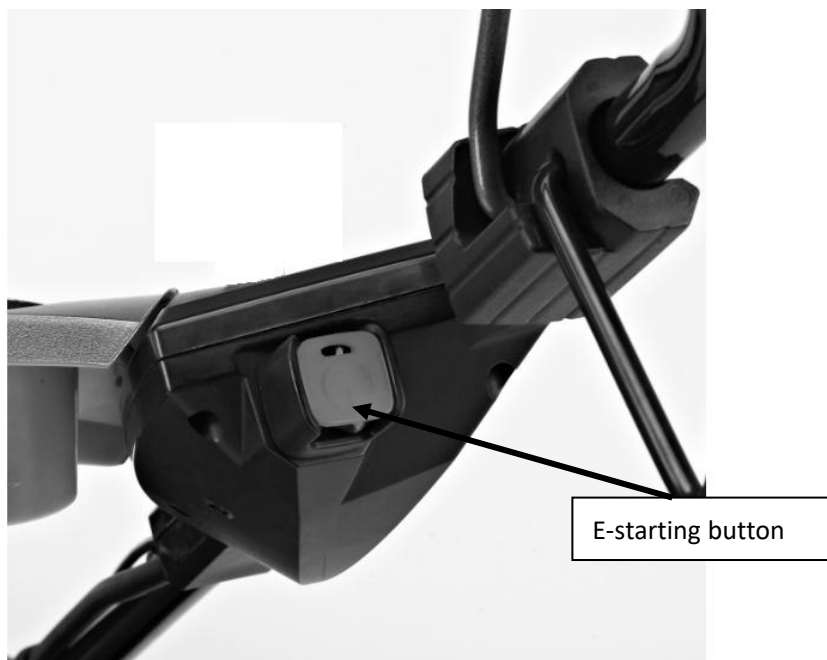

- Pull back on the operator control lever and hold it against the handle (the clutch lever must not be activated).
- Push the E-starting button to start the machine.

**b) Operation (for all models)**

Blade is in action as soon as engine started. While the machine is working maintain the security handle in working position. The engine will stop as soon as you release the engine control bar. Release the lever to stop the engine whenever you need to leave the mower.

**Clutch Lever**

Push the clutch lever forward and hold it against the handlebar to propel the mower forward. Release the clutch lever to stop the mower's forward movement.

Always release the clutch lever before starting the engine. If the clutch is engaged, the mower will move forward.

Operate the clutch lever with a quick and complete motion, so the clutch is either fully engaged or fully released. Hold the clutch lever against the handlebar during self-propelled mowing. This will help to extend the service life of the clutch mechanism.

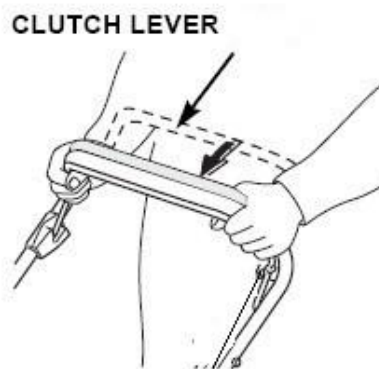

**Stop Engine**

- Release the clutch lever.

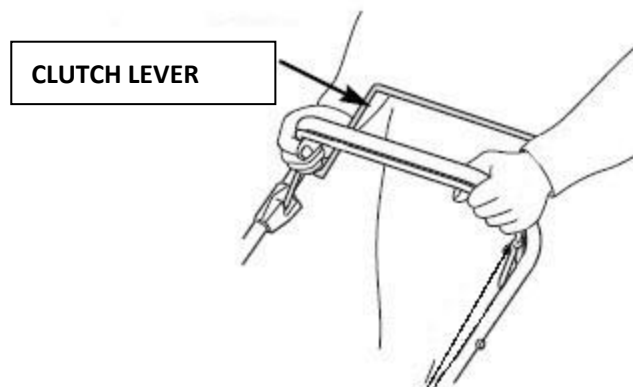

- Release the brake lever.

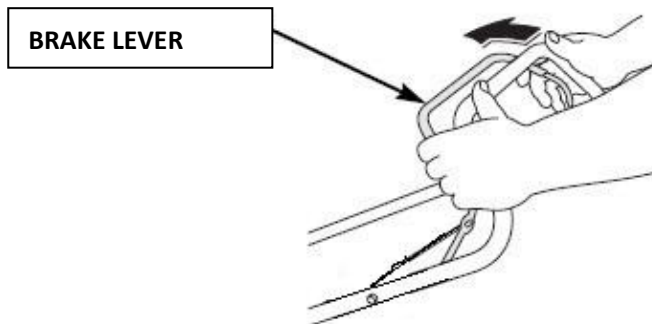

The blade will continue to rotate for a few seconds after the engine has stopped. Disconnect the spark plug cap if the lawnmower is to be left unattended.

## 6. Maintenance

---

**IMPORTANT** Regular, careful maintenance is essential for keeping the safety level and original performance of the machine unchanged in time.

- Keep all nuts, bolts and screws tight to be sure the equipment is in safe working condition. Regular maintenance is essential for safety and performance.
- Never store the equipment with fuel in the tank inside a building where vapour may reach a flame or a spark or a source of extreme heat.
- Allow the engine to cool before storing in an enclosed space.
- To reduce the fire hazard, keep the engine, exhaust silencer, battery compartment and fuel storage area free of grass, leaves, or excessive grease. Do not leave containers with grass cuttings in rooms.
- For reasons of safety, do not use the equipment with worn or damaged parts. Parts are to be replaced and not repaired. Use genuine spare parts (blades should always bear the symbol). Parts that are not of the same quality can damage the equipment and be dangerous for your safety.
- If the fuel tank has to be drained, this should be done outdoors and when the engine is cool.
- Wear strong work gloves when removing and reassembling the blade.
- Check the blade's balance after sharpening.
- Check the self-closing guard and grass-catcher frequently for wear and deterioration.
- Whenever the machine is to be handled, transported or tilted you must:
  - Wear strong working gloves;
  - Grasp the machine at the points that offer a safe grip, taking account of the weight and its distribution.

### Blade

#### Inspection

- Tilt the mower to the right, so the air cleaner side is up. This will help to prevent fuel leakage and hard starting.
- Inspect the blade for damage, cracks and excessive rust or corrosion.  
A dull blade can be sharpened, but a blade that is excessively worn, bent, cracked, or otherwise damaged must be replaced.
- A torque wrench must always be used when installing the blade.  
Check that the blade bolts are tight.

#### Removal and installation

If you remove the blade for sharpening or replacement, you will need a torque wrench for installation. Wear heavy gloves to protect your hands.

- Remove the bolt with a socket wrench. Use a wooden block to prevent the blade from turning when removing the bolt. Then remove the blade.
- Install the blade using the blade bolt and special washers. Be sure to install the special washers with the concave side toward the blade and the convex side toward the bolt.

- Tighten the blade bolt with a torque wrench. Use a wooden block to prevent the blade from turning when tightening the bolt.

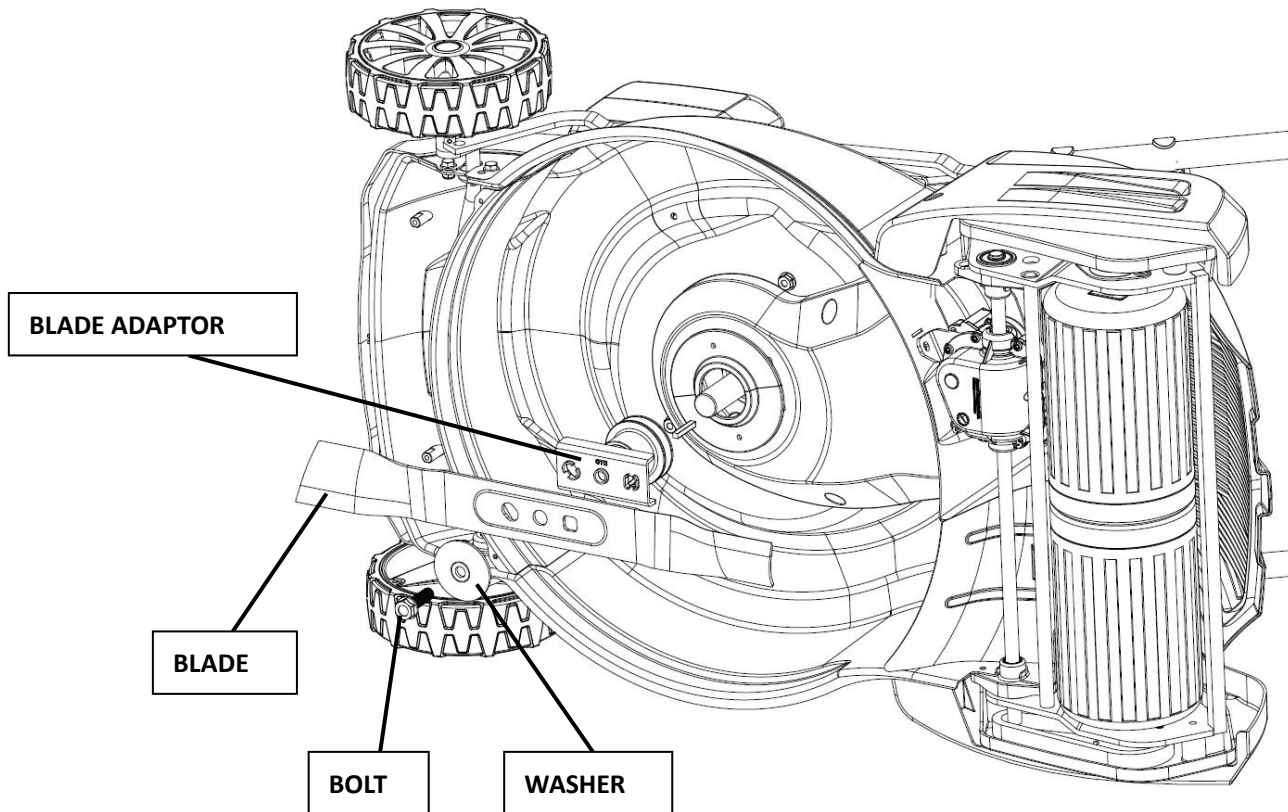

### Grass Bag Cleaning and Replacement

#### Cleaning

Wash the bag with a garden hose, and allow it to dry completely before use; a wet bag will clog quickly.

#### Replacement

- Unclip the plastic edges of the bag from the frame, remove the frame from the bag.
- Insert the frame into the bag, clip the plastic edges of the bag onto the frame.

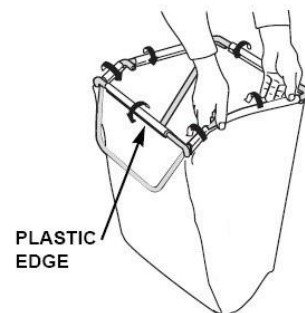
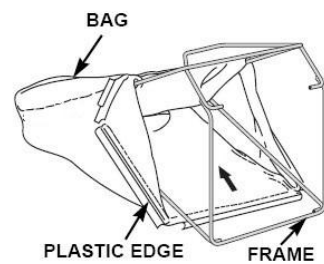

## Engine Maintenance

### Check Engine Oil Level

Check the engine oil level with the engine stopped and the mower.

- Remove the oil filler cap, and wipe the dipstick clean.
- Insert the dipstick into the oil filler neck, but do not screw it in.
- Check the oil level shown on the dipstick. If near the lower, fill to the upper level with the oil. Do not overfill.
- Screw in the filler cap securely.

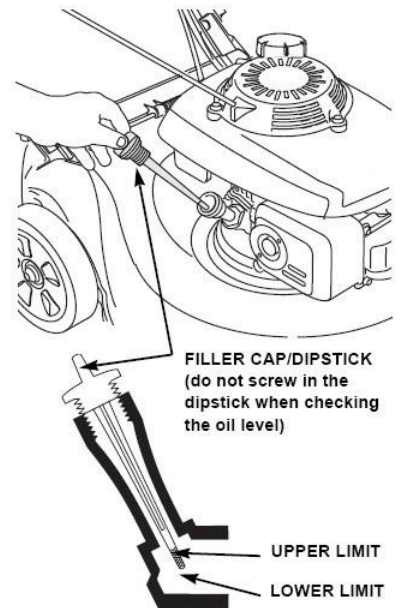

**NOTICE:** Running the engine with a low oil level will cause engine damage.

### Change Engine Oil

Drain the used oil while the engine is warm. Warm oil drains quickly and completely.

- Wipe the oil filler area clean, then remove the oil filler cap/dipstick.
- Place a suitable container next to the mower to catch the used oil, then tilt the mower on its right side. The used oil will drain through the filler neck. Allow the oil to drain completely. Please dispose of used motor oil and the containers in a manner that is compatible with the environment. We suggest you take it in a sealed container to your local recycling center or service station for reclamation. Do not throw it in the trash, pour it on the ground, or pour it down a drain.
- Fill with the recommended oil. Do not overfill. Allow a couple of minutes for the oil to settle in the engine, then measure the oil level.

### Air Cleaner Service

**NOTICE:** Operating the engine without an air cleaner, or with a damaged air cleaner, will allow dirt to enter the engine, causing rapid engine wear.

- Press down on the cover tabs and remove the cover.
- Remove the filter from the air cleaner base.
- Inspect the filter and foam element, and replace it if damaged.
- Clean the filter by tapping it several times on a hard surface to remove dirt, or blow compressed air through

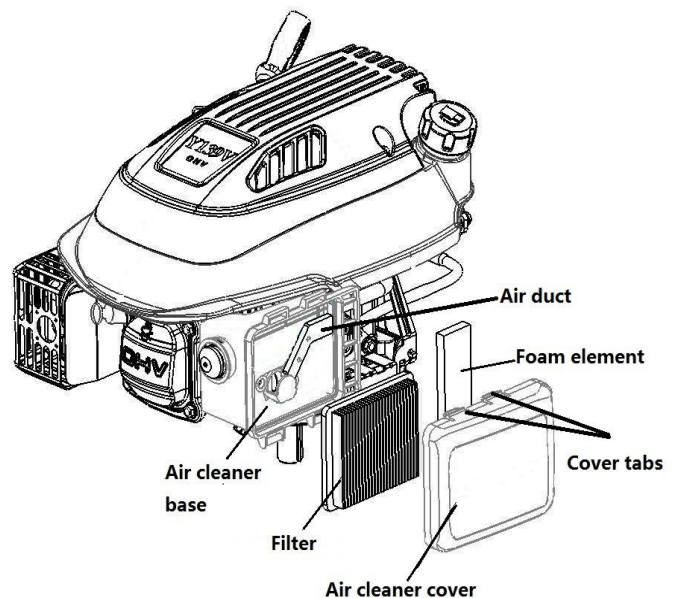

the air filter from the inside. Never try to brush off dirt; brushing will force dirt into the fibers.

- Wipe dirt from the inside of the air cleaner base and cover, using a moist rag. Be careful to prevent dirt from entering the air duct that leads to the carburetor.
- Reinstall the filter and cover.

### Spark Plug Service

For good performance, the spark plug must be properly gapped and free of deposits.

- Disconnect the spark plug cap and remove any dirt from around the spark plug area.

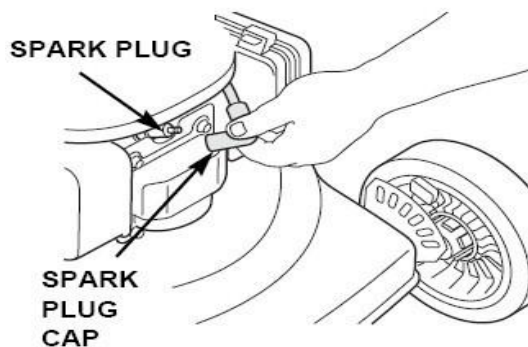

- Remove the spark plug with a spark plug wrench.

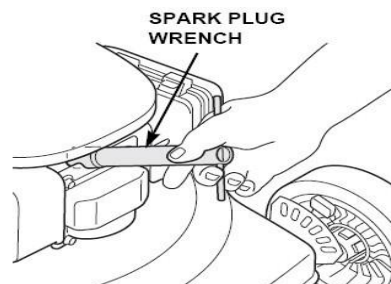

- Inspect the spark plug. Replace it if the electrodes are worn, or if the insulator is cracked or chipped.
- Measure the spark plug electrode gap with a suitable gauge. The gap should be 0.028 ~ 0.031 in (0.7 ~ 0.8mm). Correct the gap, if necessary, by carefully bending the side electrode with a suitable tool.

0.028 ~ 0.031 in  
(0.7 ~ 0.8 mm)

SEALING  
WASHER

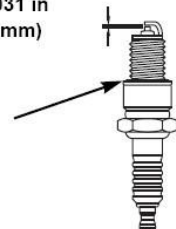

- Install the spark plug carefully, by hand, to avoid cross-threading.
- Install the spark plug cap on the spark plug.

**NOTICE:** A loose spark plug can overheat and damage the engine. Over tightening the spark plug can damage the threads in the cylinder head.

### The Clutch Lever Cable and Brake lever Cable Adjustment

- If the clutch lever were loose, you should turn the clutch cable adjustment to tighten. (please see the picture)

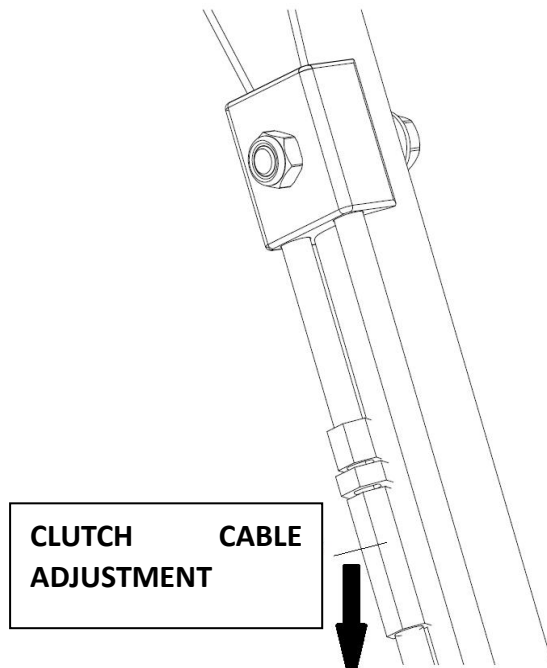

- If the brake lever were loose, you should turn the brake cable adjustment to tighten. (please see the picture)

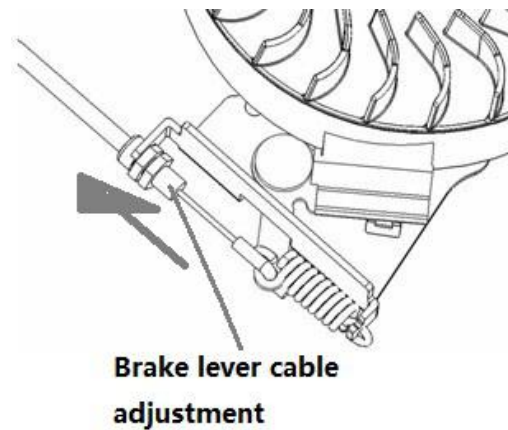

**Maintenance Schedule**

REGULAR PERIOD(4)	SERVICE	Before Each Use	First Month or 5 Hrs	Every 3 Months or 25 Hrs	Every 6 Months or 50 Hrs	Every Year or 100 Hrs	Every Two Years or 250 Hrs
ITEM Perform at every indicated month or operating hour interval, whichever comes first.							
Engine oil	Check	O					
	Replace		O	O(2)			
Air cleaner	Check		O				
	Replace			O			
Spark plug	Check-adjust					O	
	Replace						O
Flywheel brake pad (A types)	Check					O	
Fuel tank and filter	Clean			O			
Fuel tube	Check	Every 2 years (Replace if necessary)					
Valve clearance	Check-adjust					O	
Combustion chamber	Clean	After every 200 hours					

**Trouble Shooting**

ENGINE WILL NOT START	Possible Cause	Correction
1. Check fuel.	Out of fuel.	Refuel
	Bad fuel; engine stored without treating or draining gasoline, or refueled with bad gasoline	Drain the fuel tank and carburetor. Refuel with fresh gasoline.
2. Remove and inspect spark plug.	Spark plug faulty, fouled, or improperly gapped.	Replace the spark plug.
	Spark plug wet with fuel (flooded engine).	Dry and reinstall spark plug.
3. Take engine to an authorized our servicing dealer, or refer to shop manual.	Fuel filter clogged, carburetor malfunction, ignition malfunction, valves stuck, etc.	Replace or repair faulty components as necessary.
4. Push the prime button	In cold condition	Push the prime button.



ENGINE LACKS POWER	Possible Cause	Correction
1. check air cleaner	Air cleaner elements clogged.	Clean or replace air cleaner elements
2. Check fuel	Bad fuel; engine stored without treating or draining gasoline, or refueled with bad gasoline.	Drain the fuel tank and carburetor. Refuel with fresh gasoline.
3. Take engine to an authorized our servicing dealer, or refer to shop manual.	Fuel filter clogged, carburetor malfunction, ignition malfunction, valves stuck, etc.	Replace or repair faulty components as necessary.

**6. Storage**

- The same petrol must not remain in the tank for more than one month.
- Thoroughly clean the mower and store it indoors in a dry place.
- Never store the lawnmower with fuel in the tank inside a building where can reach an open flame or spark.
- To reduce fire hazard, keep the engine, muffler, battery compartment and fuel storage area free of grass, leaves or excessive grease.
- If the fuel tank has to be drained, this should be done outdoors.
- Be careful during adjustment of the machine to prevent entrapment of the fingers between moving blade and fixed parts of the machine.
- Allow the product to cool for at least 30 minutes before storing.

## 7. Declaration of conformity

---



BUILDER SAS

32, rue Aristide Bergès - ZI 31270 Cugnaux - France

Declares that the machinery designated below:

Hereby declare under our sales responsibility that the product

**Product: PETROL ROLLER MOWER**

**MODEL: FTDTR4240ES**

**S/N: 20220308572-20220308861**

To which this declaration relates is in conformity which the following directives and standards:

**Machinery Directive: 2006/42/EC**

EN ISO 5395-1:2013+A1:2018

EN ISO 5395-2:2013+A1:2016+A2:2017

**Directive of Electromagnetic Compatibility: 2014/30/EU**

**Standard EN ISO 14982: 2009**

**Directive Emission 2016/1628/EU & 2018/989/EU**

**Type approval e24\*2016/1628\*2018/989SYA1/P\*0051\*01**

**Noise Directive 2000/14/EC annex III amended by 2005/88/EC**

	<b>FTDTR4240/FTDTR4240ES</b>
<b>sound power level</b>	L <sub>WA</sub> = 93.97dB(A) K=1.75 dB(A)
<b>guaranteed sound power level</b>	96 dB(A)

Cugnaux, 18/01/2022

Philippe MARIE / PDG

Responsible of the technical file: M. Olivier Patriarca

## 8. WARRANTY



### WARRANTY

The manufacturer guarantees the product against defects in material and workmanship for a period of 2 years from the date of the original purchase. The warranty only applies if the product is for household use. The warranty does not cover breakdowns due to normal wear and tear.

The manufacturer agrees to replace parts identified as defective by the designated distributor. The manufacturer does not accept responsibility for the replacement of the machine, in whole or in part, and/or ensuing damage.

**The warranty does not cover breakdowns due to:**

- insufficient maintenance.
- abnormal assembly, adjustment or operations of the product.
- parts subject to normal wear and tear.

**The warranty does not extend to:**

- shipping and packaging costs.
- using the tool for a purpose other than that for which it was designed.
- the use and maintenance of the machine done in a manner not described in the user manual.

Due to our policy of continuous product improvement, we reserve the right to alter or change specifications without notice. Consequently, the product may be different from the information contained therein, but a modification will be undertaken without notice if it is recognized as an improvement of the preceding characteristic.

**READ THE MANUAL CAREFULLY BEFORE USING THE MACHINE.**

When ordering spare parts, please indicate the part number or code, you can find this in the spare parts list in this manual. Keep the purchase receipt; without it, the warranty is invalid. To help you with your product, we invite you to contact us by phone or via our website:

- **+33 (0)9.70.75.30.30**
- **<https://services.swap-europe.com/contact>**

You must create a "ticket" via the web platform.

- Register or create your account.
- Indicate the reference of the tool.
- Choose the subject of your request.
- Describe your problem.
- Attach these files: invoice or sales receipt, photo of the identification plate (serial number), photo of the part you need (for example: pins on the transformer plug which are broken).



# 9. PRODUCT FAILURE

## WHAT TO DO IF MY MACHINE BREAKS DOWN?

### If you bought your product in a store:

- a) Empty the fuel tank if your product has one.
- b) Make sure that your machine is complete with all accessories supplied, and clean! If this is not the case, the repairer will refuse the machine.

Go to the store with the complete machine and with the receipt or invoice.

### If you bought your product on a website:

- a) Empty the fuel tank if your product has one.
- b) Make sure that your machine is complete with all accessories supplied, and clean! If this is not the case, the repairer will refuse the machine.
- c) Create a SWAP-Europe service ticket on the site: <https://services.swap-europe.com> When making the request on SWAP-Europe, you must attach the invoice and the photo of the nameplate (serial number).
- d) Contact the repair station to make sure it is available before dropping of the machine.

Go to the repair station with the complete machine packed, accompanied by the purchase invoice and the station support sheet downloadable after the service request is completed on the SWAP-Europe site

For machines with engine failure from manufacturers BRIGGS & STRATTON, HONDA and RATO, please refer to the following instructions.

Repairs will be done by approved engine manufacturers of these manufacturers, see their site:

- <http://www.briggsandstratton.com/eu/fr>
- <http://www.honda-engines-eu.com/fr/service-network-page;jsessionid=5EE8456CF39CD572AA2AEEDFD290CDAE>
- <https://www.rato-europe.com/it/service-network>

**Please keep your original packaging to allow for after-sales service returns or pack your machine with a similar cardboard box of the same dimensions.**

**For any question concerning our after-sales service you can make a request on our website <https://services.swap-europe.com>**

**Our hotline remains available at +33 (9) 70 75 30 30.**



# 10. WARRANTY EXCLUSIONS

## THE WARRANTY DOES NOT COVER:

- Start-up and setting up of the product.
- Damage resulting from normal wear and tear of the product.
- Damage resulting from improper use of the product.
- Damage resulting from assembly or start-up not in accordance with the user manual.
- Breakdowns related to carburetion beyond 90 days and fouling of carburetors.
- Periodic and standard maintenance events.
- Actions of modification and dismantling that directly void the warranty.
- Products whose original authentication marking (brand, serial number) has been degraded, altered or withdrawn.
- Replacement of consumables.
- The use of non-original parts.
- Breakage of parts following impacts or projections.
- Accessories breakdowns.
- Defects and their consequences linked to any external cause.
- Loss of components and loss due to insufficient screwing.
- Cutting components and any damage related to the loosening of parts.
- Overload or overheating.
- Poor power supply quality: faulty voltage, voltage error, etc.
- Damages resulting from the deprivation of enjoyment of the product during the time necessary for repairs and more generally the costs related to the immobilization of the product.
- The costs of a second opinion established by a third party following an estimate by a SWAP-Europe repair station
- The use of a product which would show a defect or a breakage which was not the subject of an immediate report and/or repair with the services of SWAP-Europe.
- Deterioration linked to transport and storage\*.
- Launchers beyond 90 days.
- Oil, petrol, grease.
- Damages related to the use of non-compliant fuels or lubricants.

\* In accordance with transport legislation, damage related to transport must be declared to carriers within 48 hours maximum after observation by registered letter with acknowledgement of receipt.

This document is a supplement to your notice, a non-exhaustive list.

**Attention:** all orders must be checked in the presence of the delivery person. In case of refusal by the delivery person, it you must simply refuse the delivery and notify your refusal.

**Reminder:** the reserves do not exclude the notification by registered letter with acknowledgement within 72 hours.

### Information:

Thermal devices must be wintered each season (service available on the SWAP-Europe site). Batteries must be charged before being stored.