



## **4-STROKE PETROL BLOWER**

**FST264T**

### **USER GUIDE**

**CAUTION:** Read the instructions before using this machine.

# CONTENTS

1. SAFETY INSTRUCTIONS .....	3
2. EXPLANATION OF SYMBOLS .....	5
3. INTENDED USE .....	7
4. KNOW YOUR PRODUCT .....	7
5. ASSEMBLY .....	8
6. OPERATION .....	12
7. MAINTENANCE .....	14
8. CLEANING AND STORAGE .....	17
9. TROUBLESHOOTING .....	18
10. DECLARATION OF CONFORMITY .....	19
11. WARRANTY .....	20
12. PRODUCT FAILURE .....	21
13. WARRANTY EXCLUSIONS .....	22

# 1. SAFETY INSTRUCTIONS

## 1.2 GENERAL WARNINGS

**WARNING:** For your own safety, please read this manual before attempting to operate your new unit. Failure to follow instructions can result in serious personal injury. Spend a few moments to familiarize yourself with your blower before each use. If you give this tool to another person, also hand over this manual.

Use this tool as described in this manual. Any mishandling and any use contrary to the instructions will not in any way engage the liability of the manufacturer.

Non-compliance with safety instructions and use can cause a risk of electric shock, fire and /or injury to persons.

### READ YOUR USER MANUAL THOROUGHLY BEFORE OPERATING YOUR UNIT.

- Never allow children, handicapped or inexperienced people to use the machine. Local regulations may restrict the age of the user.
- Keep children, bystanders and animals away from the machine when using it (at least 15 meters).
- Remember that the user is responsible for accidents or damage to people or their property.
- Never dismantle the machine by yourself. Any disassembly or repair must be carried out by qualified personnel.
- Always wear personal protective equipment (PPE)
- Wear long, thick pants, boots, eye protection and safety gloves. Do not wear loose clothing, shorts or jewellery, and never work barefoot.
- To reduce the risk of injury, never wear loose clothing, scarf, collar, chain, etc. as they could get caught in moving parts. If you have long hair, be sure to tie it above shoulder level to prevent it from getting caught in the moving parts.
- The machine is extremely noisy and requires the use of good quality hearing protection every time you use it.
- Carry the machine only by its handle. Never try to wear it in other places.
- Refuel only in safe places. Open the tank slowly to release any pressure that may have built up in the tank. Clean any gasoline or spills from the machine before using it. To prevent any risk of fire, move at least 10 meters away from the refuelling area before starting the machine.
- Switch off the machine before any preparation, installation or maintenance.
- All machine screws should be properly seated and tightened securely. The machine must be in good working order. Never use this machine if it is not assembled correctly.
- Keep handles clean and dry and free from gasoline or oil.
- Always store the machine in a clean and dry place away from all electrical equipment.
- Never start the engine in a closed or poorly ventilated room as the exhaust gases can be fatal.
- Only operate the machine at reasonable times - not too early in the morning or late at night, when people may be disturbed.
- Never use the machine in bad weather or if there is a risk of lightning or thunderstorms. Do not use in the rain or in wet areas.
- Do not use this machine if you are tired, sick, under the influence of alcohol or drugs, or if you are taking medication.
- Do not use this machine in a poorly lit area.
- Keep a safe distance from moving parts and never touch surfaces that become hot during use.
- Wear a mask that filters out microscopic particles if your work generates dust, to avoid the risks associated with inhaling harmful dust.

- Before starting the machine, clear the area where you are going to use it. Remove stones, broken glass, nails, wire ropes, ropes or other objects that could be thrown or get caught in the machine.
- Always keep a good balance. Support yourself well on your legs and do not extend your arm too far. Otherwise, you could fall, slip or injure yourself.
- Let your machine cool down before putting it away.
- Before transporting this machine in a vehicle, empty the fuel tank and secure the machine so that it cannot move during transport.
- To reduce the risk of fire and burns, handle fuel with care. It is an extremely flammable substance.
- Do not smoke when handling fuel.
- Mix and store fuel in a container designed to hold gasoline.
- Mix the fuel in the open air, away from any sparks or flames.
- Choose a clean, bare surface, stop the engine, and allow it to cool before filling it.
- Slowly unscrew the fuel cap to relieve pressure and prevent fuel from spilling around the cap.
- Screw on the tank cap firmly after filling.
- Wipe down the machine if you have spilled fuel.
- Move at least 10m away from where you filled the fuel tank before starting the engine.
- Never attempt to burn spilled fuel.
- When replacing, use only replacement parts and accessories recommended by the manufacturer. Failure to do so could reduce the efficiency of your machine and put you at risk of injury.
- Maintain your machine with care, according to the instructions in the "Maintenance" section of this manual.
- Check the condition of your machine before each use. Make sure that the fasteners are tight, that there are no fuel leaks and that no parts are damaged.
- Replace any damaged part.
- To reduce the risk of injury from contact with moving parts, stop the engine before installing or removing accessories.
- Do not use your machine if the protective elements are not installed. Always remove the spark plug before carrying out any maintenance or working on any moving part.
- Do not point the blower nozzle at people or pets.
- Never start this machine if the required accessories are not installed.
- Do not operate the machine near open windows,
- Use a rake and broom to loosen debris before blowing.
- Lightly dampen surfaces in dusty conditions before working.
- Use the pipes fully assembled so that the air flow can reach the floor.
- Caution: there is a risk of danger from rotating parts. Avoid coming into contact with them.
- In case of blockage or breakdown, stop using the machine immediately. Inspect it and remove the blockage securely (see chapter "Maintenance"). In the event of a fault, please take your machine to a qualified service for inspection.

### **Fuel handling**

- Be very careful when handling fuels. They are flammable and the vapors are explosive.
- Use only an approved container.
- Never remove the fuel cap or add fuel while the machine is on. Turn off the unit and allow the engine and exhaust components to cool before refuelling.
- Do not smoke.
- Never refuel inside a room
- Never store the tool and the fuel tray indoors where there is a naked flame, such as near a water heater.

- If fuel has spilled, do not attempt to start the machine, but rather move it away from the spill before starting to use it. Clean any spills.
- Replace and tighten the fuel tank cap after refuelling.
- Follow the instructions in this manual for filling the tool with fuel.

### **Maintenance and storage**

When the machine is stopped for servicing, inspection, or storage, or to change an accessory, shut off the power source and make sure that all moving parts have come to a complete stop. Allow the machine to cool before making any inspections, adjustments, etc. Maintain the machine with care and keep it clean.

- Store the machine in a dry place out of the reach of children.
- Always allow the machine to cool before storing.
- Replace worn or damaged parts for safety. Use only genuine replacement parts and accessories.
- Never attempt to override the interlocked feature of the guard.



### **Residuals risks**















Even if you use this product in compliance with all safety requirements, potential risks of injury and damage remain. The following hazards may arise from the structure and design of this product. Always be vigilant when using this product, so you can recognize and manage the risks early. Rapid intervention can prevent serious injury and property damage. Turn off the tool if there are any malfunctions. Have it checked by a qualified professional and have repairs carried out, if necessary, before using it again.

- There are harmful health consequences resulting from the emission of vibrations if the product is used for long periods of time or not properly managed and properly maintained.
- There is risk of injury and property damage due to attachments or broken the sudden impact of hidden objects.
- Risk of injury to persons and property caused by flying objects
- Inhalation of gasoline particles or toxic gases.
- Contact with moving parts. (Ex: Danger related to the starter handle (Risk of kickback))
- Hearing loss if hearing protection is not worn.

## **2. EXPLANATION OF SYMBOLS**

This operator's manual describes safety and international symbols and pictographs that may appear on this product. Read the operator's manual for complete safety, assembly, operating and maintenance and repair information.

	<p>To reduce the risk of injury, user must read and understand operator's manual before using this product.</p>
	<p>Keep all bystanders at least 15 m away.</p>
	<p>Wear protective goggles.</p>

	Wear hearing protection.
	Wear safety shoes.
	Wear protective gloves.
	Rotating impeller blades can cause severe injury
	Failure to keep loose clothing from being drawn into air intake could result in personal injury.
	Failure to keep hair into air intake could result in personal injury.
	Conforms to relevant safety standards
	Guaranteed sound power level: 105dB (A).
	1. • RUN choke position 2. • PARTIAL choke position 3. • FULL choke position
	OFF or STOP
	ON / START / RUN
	Hot surface
	Primer bulb
	Warning symbol

## 3. INTENDED USE

This engine gasoline powered blower is intended for Cleaning yards, garages, driveways, porches, patios, around walls, fences, etc.

This product is intended for blower use only and is not designed for vacuum use.

Do not attempt to open air inlet cover that covers the impeller. Opening the air inlet cover may result in contact with the impeller blades and cause serious personal injuries.

## 4. KNOW YOUR PRODUCT

### 4.1 PRODUCT DESCRIPTION

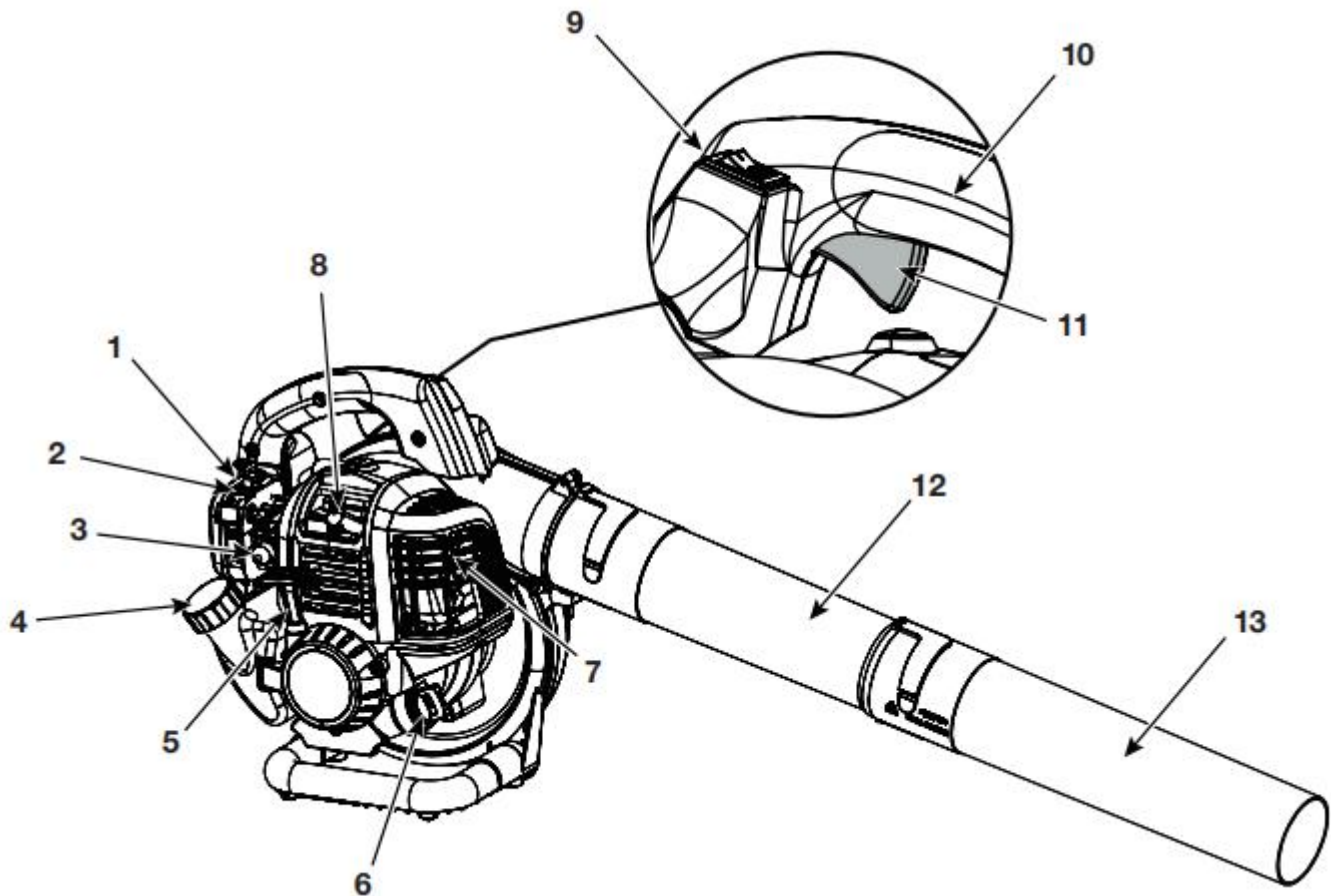

- 1 Air Filter Cover
- 2 Choke Lever
- 3 Primer Bulb
- 4 Fuel Cap
- 5 Starter Rope Grip
- 6 Oil Fill Plug
- 7 Muffler
- 8 Spark Plug Cover
- 9 On/Off Switch
- 10 Handle
- 11 Throttle Control
- 12 Upper Blower Tube
- 13 Lower Blower Tube

## 4.2 TECHNICAL DATA

Engine Type	Air-Cooled, 4-STROKE
Engine displacement	26.5 cm <sup>3</sup>
Maximum engine capacity	0.65 kW
Engine rating speed	7000min <sup>-1</sup>
Engine max speed	11000min <sup>-1</sup>
Engine min speed	3500+/-300 min <sup>-1</sup>
Air speed	198 km/h
Air volume	690 m <sup>3</sup> /h
Fuel tank capacity	280 cm <sup>3</sup> / 0.28 L
Lubricating tank capacity	60 cm <sup>3</sup> / 0.06L
Net weight (without fuel)	4.0 kg
Sound pressure level LpA	87.9 dB(A), K=3dB(A)
Guaranteed sound power level LwA	105 dB(A)
Measured sound power level LwA	100.3 dB(A), K=3dB(A)
Main handle ah	13.2 m/s <sup>2</sup>
Aux. handle: ah	10.4 m/s <sup>2</sup>
Uncertainty K	1.5 m/s <sup>2</sup>

## 5. ASSEMBLY



### WARNING!

To avoid serious personal injury and damage to the unit, shut the unit off before removing or installing blower tubes or nozzles.



### WARNING!

To prevent serious personal injury, never operate the unit without the upper blower tube firmly installed.

### 5.1 INSTALLING THE BLOWER TUBE(S)

Always install the upper blower tube. The lower blower tube is optional.

#### 1) Installing the Upper Blower Tube

- Align the slots on the upper end of the upper blower tube with the bumps on the blower outlet (Fig. 1).
- Insert the upper blower tube into the blower outlet (Fig. 1).
- While holding the handle, twist the upper blower tube clockwise until it locks into place (Fig. 1).

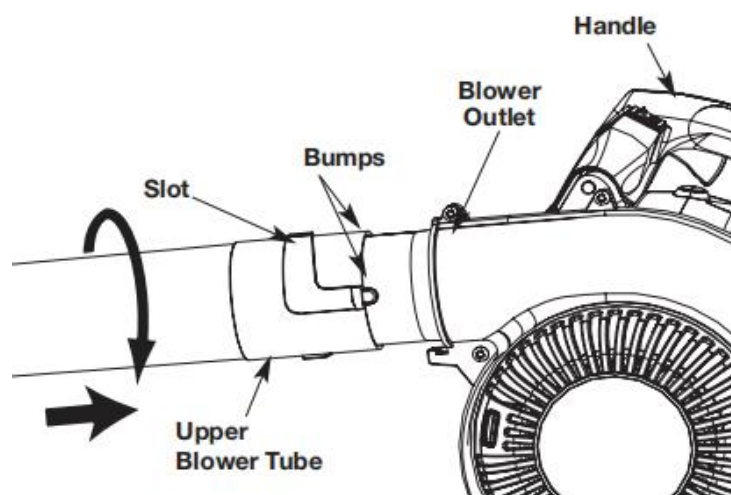

Fig. 1



## 2) Installing the Lower Blower Tube

- Align the slots on the lower blower tube with the bumps on the lower end of the upper blower tube (Fig. 2).
- Install the lower blower tube onto the upper blower tube (Fig. 2).
- While holding the upper blower tube, twist the lower blower tube clockwise until it locks into place (Fig. 2).

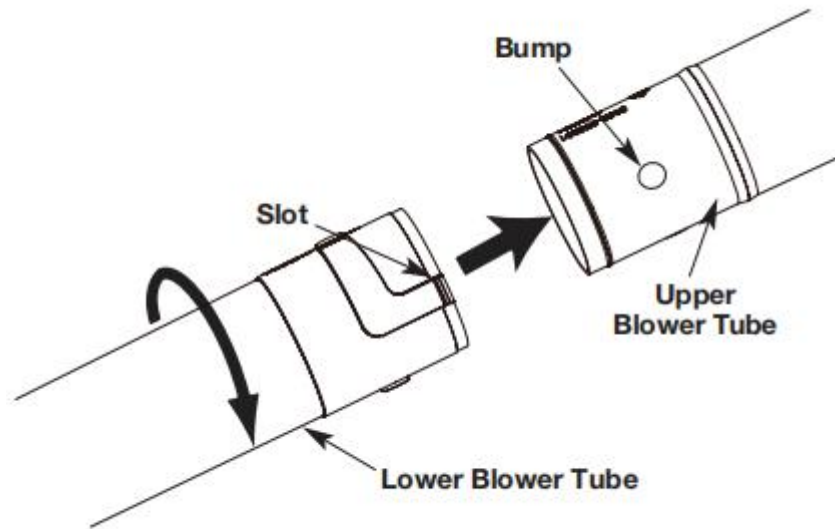

Fig. 2

## 3) REMOVING THE BLOWER TUBE(S)

### • Removing the Upper Blower Tube

- Twist the upper blower tube counterclockwise until it unlocks from the blower outlet (Fig. 3).
- Remove the upper blower tube from the blower outlet.

### • Removing the Lower Blower Tube

- While holding the upper blower tube, twist the lower blower tube counterclockwise until it unlocks from the blower tube.
- Remove the lower blower tube from the upper blower tube.

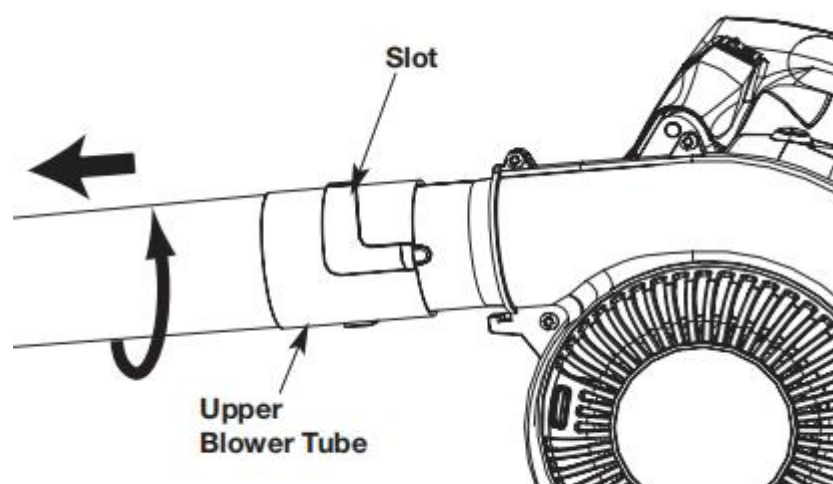

Fig. 3

## 4) USING THE RIGHT OIL

Use a high-quality SAE 30 weight oil. DO NOT use dirty oil. Failure to use clean oil of the correct type can cause premature engine wear and failure.

## 5) ADDING OIL: INITIAL USE

**! WARNING !**

OVERFILLING THE CRANKCASE MAY CAUSE SERIOUS PERSONAL INJURY. Check the oil level before each use. The importance of maintaining the proper oil level cannot be overemphasized. Change the oil according to the Maintenance Schedule.

**Note:** This unit was shipped without oil in the crankcase. Oil must be added before starting the unit.

Note: This unit comes with a 60 ml container of oil.

- a) Set the unit on a flat, level surface.
- b) Unscrew the oil fill plug (Fig. 4).
- c) Pour the entire container of oil into the oil fill hole (Fig. 4).

**DO NOT** overfill. Refer to Checking the Oil Level

**Note:** Never add oil to the fuel tank. This unit has a four-cycle engine. DO NOT mix oil with gasoline.

- d) Wipe up any oil that may have spilled.
- e) Reinstall the oil fill plug.

**Note:** Make sure the O-ring is in place on the oil fill plug (Fig. 4).

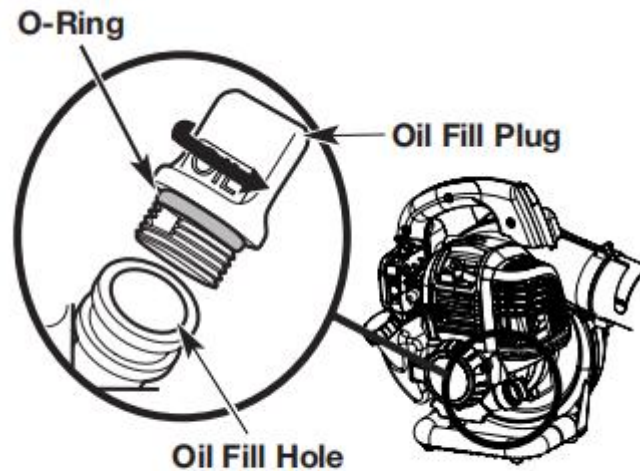

Fig. 4

## 6) USING THE RIGHT FUEL

The use of old fuel is the most common cause of performance problems. Use only fresh, clean unleaded gasoline.

**Note:** This unit has a four-cycle engine. DO NOT mix oil with gasoline.

## 7) FUELING THE UNIT

**! WARNING !**

Gasoline is extremely flammable. Ignited vapors may explode. Always stop the engine and allow it to cool before filling the fuel tank. Do not smoke while filling the tank. Keep sparks and open flames at a distance from the area.

**! WARNING!**

Remove the fuel cap slowly to avoid injury from fuel spray. Never operate the unit without the fuel cap securely in place.

**! WARNING!**

Add fuel in a clean, well ventilated outdoor area. Wipe up any spilled fuel immediately. Avoid creating a source of ignition for spilled fuel. Do not start the engine until fuel vapors dissipate.

- a) Position the unit with the fuel cap facing up.
- b) Slowly remove the fuel cap.
- c) Place the fuel container spout into the fuel tank fill hole and fill the tank.

**Note:** Do not overfill the tank.

- d) Wipe up any fuel that may have spilled.
- e) Reinstall the fuel cap.
- f) Move the unit at least 30 ft. (9.1 m) from the fuel container and the fueling site before starting the engine.

## 5.2 STARTING AND STOPPING



### WARNING!

Operate this unit only in a well-ventilated outdoor area.  
Carbon monoxide exhaust fumes can be lethal in a confined area.



### WARNING!

Avoid accidentally starting the unit. To avoid serious injury, the operator and the unit must be in a stable position when pulling the starter rope (Fig. 7).



### WARNING!

When starting the unit, make sure it is not directed toward people, animals, windows, automobiles or loose debris.



### WARNING!

Be sure to read the fuel information in the safety rules before you begin. If you do not understand the safety rules, do not attempt to fuel your unit.

### 1) STARTING INSTRUCTIONS

- a) Check the oil level. Refer to Checking the Oil Level.
- b) Fill the fuel tank. Refer to Fueling the Unit.
- c) Push the ON/OFF switch on the ON (I) position. (Fig. 5).

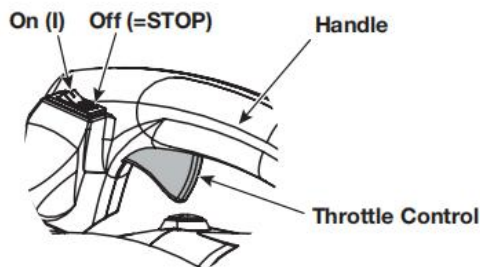

Fig. 5

- d) Slowly press the primer bulb 10 times (Fig. 6).
- e) Move the choke lever to the Full Choke position (Fig. 6).

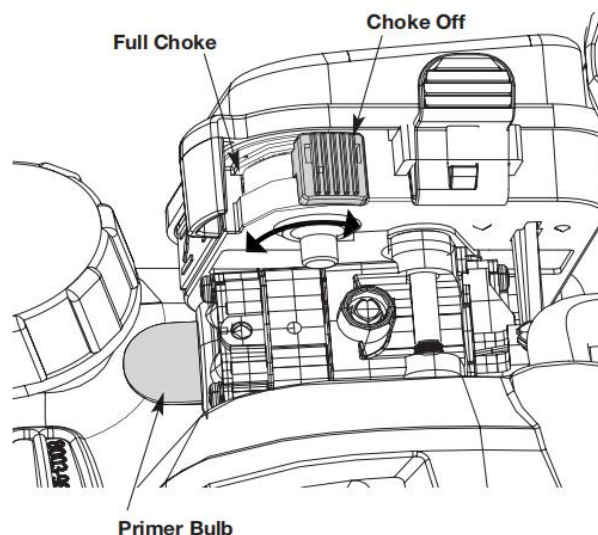

Fig. 6

- f) DO NOT squeeze the throttle control. Crouch in the starting position (Fig. 7).
- g) DO NOT squeeze the throttle control. Pull the starter rope with a controlled and steady motion 3 to 5 times to start the engine (Fig. 7).

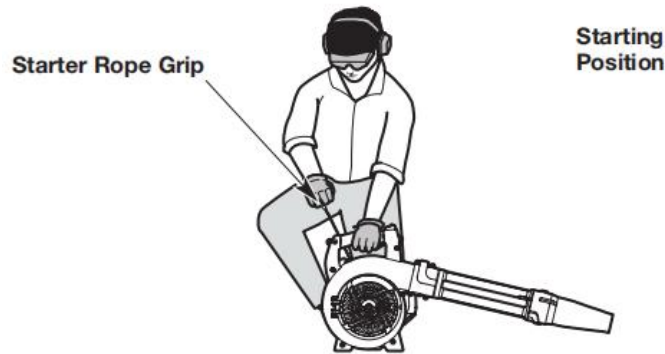

Fig. 7

- h) Allow the engine to warm up less than 10 seconds, then squeeze the throttle control to return the choke to the Choke OFF position and operate the blower.

If the engine does not start, begin the starting procedure with step 3.

If the engine fails to start after a few attempts, squeeze the throttle control to return move the choke to the Choke Off position. Pull the starter rope with a controlled and steady motion 3 to 8 times. The engine should start. If it does not, repeat this instruction.

IF THE UNIT WAS RUN FOR 10-15 MINUTES AND THE ENGINE IS HOT... perform steps 3, 5, 6, 7 to restart the engine. Squeeze and hold the throttle control. Run the unit for 2-5 minutes, or as needed. The unit may be used during this time.

If the engine speed fluctuates, move the choke lever to the Full Choke position and run the unit for 2-5 minutes, or as needed. The unit may be used during this time. Then squeeze and hold the throttle control to operate the blower.

## 2) STOPPING INSTRUCTIONS

- a) Release the throttle control and allow the engine to idle.
- b) Press and hold the ON/OFF switch in the OFF (STOP) position until the engine comes to a complete stop (Fig. 5).

# 6. OPERATION



### WARNING!

Clear the area of children bystanders, and pets. At a minimum, keep all children, bystanders, and pets outside a 15 m (50 ft) radius; outside the 15 m (50 ft) zone, there is still a risk of injury from thrown objects. Bystanders should be encouraged to wear eye protection. If you are approached, stop the engine.



### WARNING!

To prevent serious personal injury, never operate the unit without the upper blower tube firmly installed.



### WARNING!

Always wear eye, hearing, hand, foot and body protection to reduce the risk of injury when operating this unit. Wear a face mask or dust mask if the operation is dusty.



### WARNING!

To reduce the risk of injury associated with contacting rotating parts, stop the engine before installing or removing attachments. Do not operate without guards in place. Always disconnect the spark plug before performing maintenance or accessing movable parts.

## 6.1 OPERATING TIPS

- While vacuuming or blowing debris, hold the unit with the muffler side facing away from your body and clothes.
- To reduce the risk of hearing loss associated with sound level(s), hearing protection is required.
- To reduce the risk of injury associated with contacting rotating parts, stop the engine before installing or removing attachments. Do not operate without guard(s) in place.
- Operate power equipment only at reasonable hours not early in the morning or late at night when people might be disturbed. Comply with times listed in local ordinances. Usual recommendations are 9:00 a.m. to 5:00 p.m., Monday through Saturday.
- To reduce noise levels, limit the number of pieces of equipment used at any one time.
- To reduce noise levels, operate power blowers at the lowest possible throttle speed to do the job.
- Use rakes and brooms to loosen debris before blowing.
- In dusty conditions, slightly dampen surfaces when water is available.
- Conserve water by using power blowers instead of hoses for many lawn and garden applications, including areas such as gutters, screens, patios, grills, porches, and gardens.
- Watch out for children, pets, open windows, or freshly washed cars. Blow debris away safely.
- Use the full blower nozzle extension so the air stream can work close to the ground.
- After using blowers and other equipment, CLEAN UP! Dispose of debris in trash receptacles.

## 6.2 HOLDING THE UNIT

- Stand in the operating position (Fig. 8). Stand up straight. Do not bend over.
- Keep feet apart and firmly planted.
- Hold the unit in front of, and away from, your body (Fig. 8).



### WARNING!

To prevent serious personal injury or damage to the unit, DO NOT hold the unit at your side (Fig. 8). The engine may be extremely hot. DO NOT block the air intake.

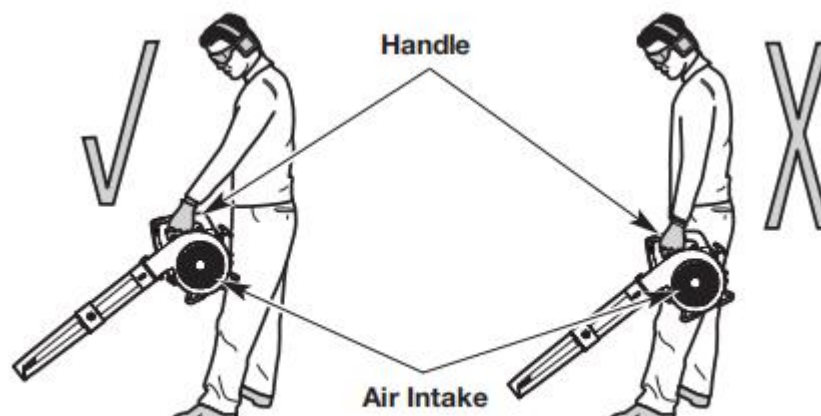

Fig. 8

# 7. MAINTENANCE

## 7.1 GENERAL RECOMMENDATIONS

The warranty on this unit does not cover items that have been subjected to operator abuse or negligence. To receive full value from the warranty, the operator must maintain unit as instructed in this manual. Various adjustments will need to be made periodically to properly maintain your unit.

**Note:** Use only original equipment manufacturer replacement parts and accessories for this unit. These are available from an authorized service dealer. The use of any unauthorized parts or accessories could lead to serious injury to the user, or damage to the unit, and void the warranty.



### WARNING!

To avoid serious personal injury, always stop the engine and allow it to cool before cleaning or maintaining the unit. Never perform cleaning or maintenance while the unit is running. Disconnect the spark plug wire to prevent the unit from starting accidentally.

Wear protective clothing and observe all safety instructions to prevent serious personal injury.

## 7.2 CHECKING THE OIL LEVEL



### WARNING!

OVERFILLING THE CRANKCASE MAY CAUSE SERIOUS PERSONAL INJURY. Check the oil level before each use. The importance of maintaining the proper oil level cannot be overemphasized.

- 1) Stop the engine and allow it to cool.
- 2) Set the unit on a flat, level surface, such as a workbench or table.

**Note:** Failure to keep the engine level may result in oil overflow.

- 3) Clean the area around the oil fill plug (Fig. 9) to prevent debris from entering the oil fill hole.

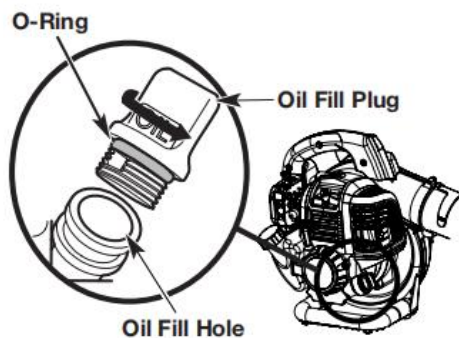

Fig. 9

- 4) Unscrew the oil fill plug.
- 5) Look into the oil fill hole; use a flashlight if necessary. Add oil to the oil fill hole until the oil level is visible on the first thread of the oil reservoir (Fig.10). If the oil level is too low, add oil to the oil fill hole until the oil level touches the bottom thread of the oil fill hole.

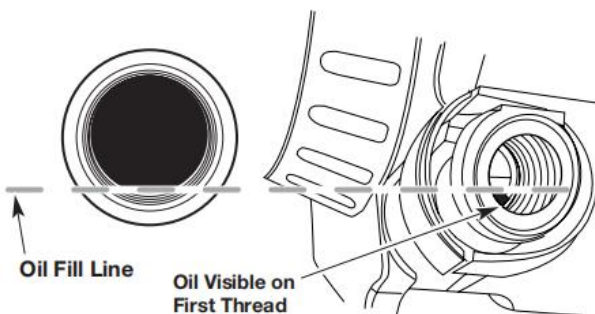

Fig. 10

**Note:** DO NOT overfill the crankcase.

- 6) Wipe up any oil that may have spilled.

7) Reinstall the oil fill plug.

**Note:** Make sure the O-ring is in place on the oil fill plug (Fig. 9).

## 7.3 MAINTENANCE SCHEDULE

Perform these required maintenance procedures at the frequency stated in the table. These procedures should also be a part of any seasonal tune-up. Some maintenance procedures may require special tools or skills. If unsure about these procedures, take the unit to a Sears or other qualified service dealer.

**Note:** Maintenance, replacement, or repair of the emission control devices and system may be performed by a qualified service dealer.

FREQUENCY	MAINTENANCE REQUIRED
Every 10 hours	Clean and re-oil the air filter. Refer to Maintaining the Air Filter.
After the first 10 hours and at 38 hours	<ul style="list-style-type: none"><li>• Change the oil. Refer to Changing the Oil.</li><li>• Have the rocker arm clearance checked by a Sears or other qualified service dealer.</li><li>• Check the spark plug condition and gap. Refer to Maintaining the Spark Plug.</li></ul>

## 7.4 CHANGING THE OIL

Change the oil while the engine is still warm. The oil will flow freely and carry away more impurities.

- 1) Clean the area around the oil fill plug (Fig. 9) to prevent debris from entering the oil fill hole.
- 2) Unscrew the oil fill plug.
- 3) Tip the unit vertically to pour the oil out of the oil fill hole and into a container (Fig. 11). Allow ample time for complete drainage.

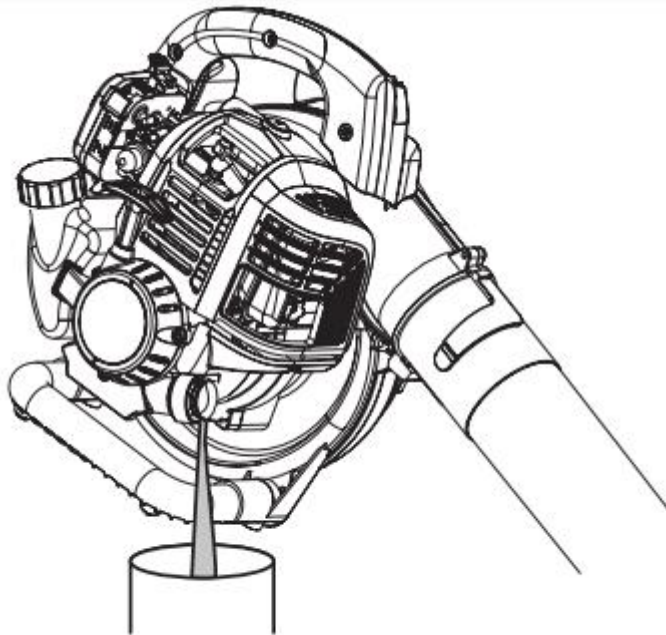

Fig. 11

4)

**Note:** Dispose of the old oil according to federal, state and local regulations.

- 5) Wipe up any oil that may have spilled.
- 6) Pour 60 ml of SAE 30 oil into the oil fill hole.

**Note:** DO NOT overfill. Refer to Checking the Oil Level.

- 7) Wipe up any oil that may have spilled.
- 8) Reinstall the oil fill plug.

**Note:** Make sure the O-ring is in place on the oil fill plug (Fig. 9).

## 7.5 MAINTAINING THE AIR FILTER

Failure to maintain the air filter can result in poor performance or can cause permanent damage to the engine. Engine failure due to improper air filter maintenance is not covered by the product warranty

- 1) Cleaning the Air Filter
- 2) Open the air filter cover: press in the lock tab and swing the air filter cover to the right (Fig. 12).
- 3) Remove the air filter (Fig. 12).
- 4) Wash the air filter in detergent and water. Rinse the air filter thoroughly and allow it to dry.
- 5) Lightly coat the air filter with clean SAE 30 oil.
- 6) Squeeze the air filter to spread and remove excess oil.
- 7) Reinstall the air filter (Fig. 12).

**Note:** Operating the unit without the air filter and air filter cover will VOID the warranty.

- 8) Close the air filter cover: insert the tabs on the air filter cover into the slots on the backplate. Swing the air filter cover to the left and press it closed until the lock tab snaps into place.

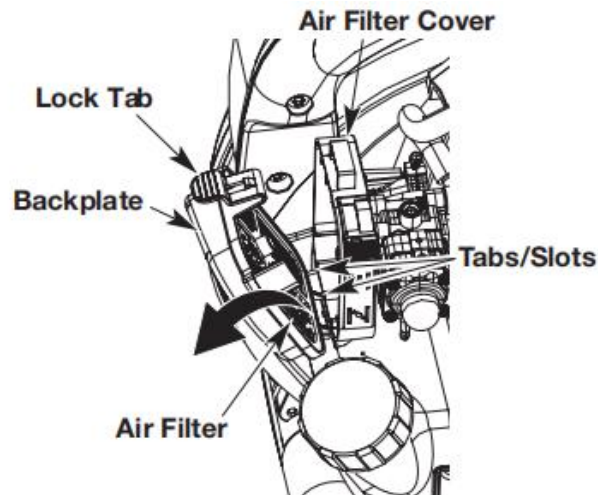

Fig. 12

## 7.6 ADJUSTING THE IDLE SPEED

If the engine will not idle properly:

- 1) Start the engine. Refer to Starting and Stopping.
- 2) Let the engine idle. If the engine stops, increase the idle speed. Use a small Phillips screwdriver to turn the idle speed screw clockwise, 1/8 of a turn at a time, until the engine idles smoothly (Fig. 13).

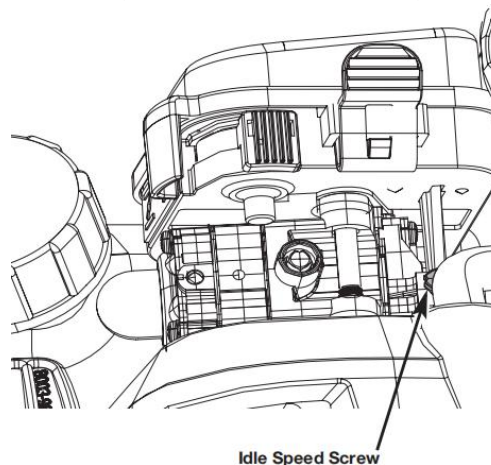

Fig. 13

## 7.7 MAINTAINING THE SPARK PLUG

If the engine will not idle properly:

- 1) Stop the engine and allow it to cool.
- 2) Grasp the spark plug boot firmly and pull it from the spark plug (Fig. 14).
- 3) Clean around the spark plug. Remove the spark plug from the cylinder head with a 5/8-inch socket, turning counterclockwise.





**WARNING!** do not sand blast, scrape or clean spark plug electrodes. Grit in the engine could damage the cylinder

- 4) Inspect the spark plug. If the spark plug is cracked, fouled or dirty, replace it with replacement part Newstar AM5C, or NGK CMR5H, or an equivalent spark plug.
- 5) Use a feeler gauge to set the air gap at 0.025 - 0.31 in. (0.6 mm - 0.8 mm) (Fig. 15).
- 6) Install the spark plug in the cylinder head. Tighten the spark plug with a 5/8-inch socket, turning it clockwise until snug.

**Note:** If using a torque wrench, torque to 18 Nm. Do not over tighten.

- 7) Reattach the spark plug boot.

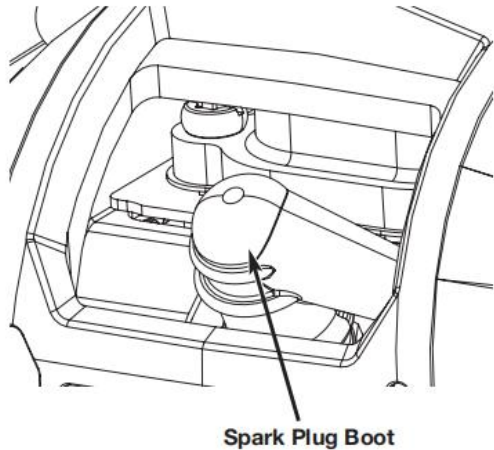

Fig. 14

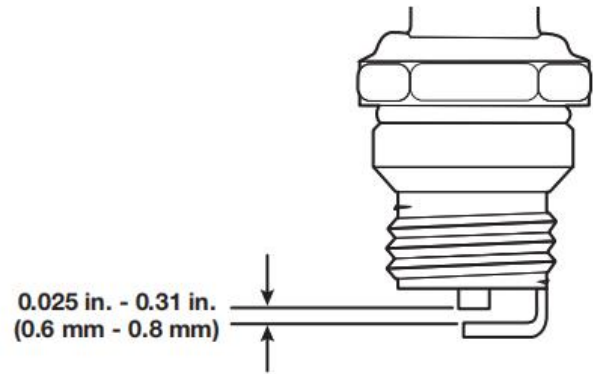

Fig. 15

## 8. CLEANING AND STORAGE

### 8.1 CLEANING



**WARNING!** to avoid serious personal injury, always stop the engine and allow it to cool before cleaning or maintaining the unit.

Use a small brush to clean the outside of the unit. Do not use strong detergents. Household cleaners that contain aromatic oils such as pine and lemon, and solvents such as kerosene, can damage plastic. Wipe off any moisture with a soft cloth.

### 8.2 STORAGE

- Never store a fueled unit where fumes may reach an open flame or spark.
- Allow the engine to cool before storing.
- Lock up the unit to prevent unauthorized use or damage.
- Store the unit in a dry, well-ventilated area.
- Store the unit out of the reach of children.

### 8.3 LONG-TERM STORAGE

- Remove the fuel cap, tip the unit and drain the fuel into an approved container. Reinstall the fuel cap.
- Start the engine and allow it to run until it stalls. This ensures that all fuel has been drained from the carburetor.
- Allow the engine to cool. Remove the spark plug and put 5 drops of any high-quality motor oil into the cylinder. Pull the starter rope slowly to distribute the oil. Reinstall the spark plug.
- Thoroughly clean the unit and inspect it for any loose or damaged parts. Repair or replace damaged parts and tighten loose screws, nuts or bolts.

## 8.4 PREPARING THE UNIT FOR USE AFTER LONG-TERM STORAGE

- Remove the spark plug. Tip the unit and drain all of the oil from the cylinder into an approved container. Reinstall the spark plug.
- Change the oil. Refer to Changing the Oil.

**Note:** Do not use fuel that has been stored for more than 30 days. Dispose of old fuel and oil according to federal, state and local regulations.

## 8.5 FUEL SYSTEM

Empty the fuel system before storage for 30 days or longer. Drain the gas tank, start the engine and let it run until the fuel lines and carburetor are empty. Use fresh fuel next season. Under OIL AND FUEL section of this manual, see message labeled IMPORTANT regarding the use of blended and E85 fuel in your engine. Fuel stabilizer is an acceptable alternative in minimizing the formation of fuel gum deposits during storage. Add stabilizer to gasoline in fuel tank or fuel storage container. Follow the mix instructions found on stabilizer container. Run engine at least 3 minutes after adding stabilizer.

## 8.6 ENGINE & OTHER

### 1) ENGINE

- Remove spark plug and pour 1 teaspoon of engine oil through the spark plug opening. Slowly pull the starter rope 8 to 10 times to distribute oil.
- Replace spark plug with new one of recommended type and heat range.
- Clean air filter.
- Check entire unit for loose screws, nuts, and bolts. Replace any damaged, broken, or worn parts.
- At the beginning of the next season, use only fresh fuel.

### 2) OTHER

- Do not store gasoline from one season to another.
- Replace your gasoline can if it starts to rust.

# 9 TROUBLESHOOTING

PROBLEM	CAUSES	SOLUTION
THE ENGINE WILL NOT START	The fuel tank is empty	Fill the fuel tank with fresh fuel
	The primer bulb was not pressed enough	Press the primer bulb 10 times
	The fuel is old (over 30 days)	Drain the fuel tank and add fresh fuel
	The spark plug is fouled	Replace the spark plug
	The engine is hot	Refer to the IF... THE ENGINE IS HOT instructions in the Starting and Stopping section
THE ENGINE WILL NOT IDLE	The air filter is dirty	Clean or replace the air filter
	The fuel is old (over 30 days)	Drain the fuel tank and add fresh fuel
	The idle speed is incorrect	Adjust the idle speed
THE ENGINE WILL NOT ACCELERATE	The fuel is old (over 30 days)	Drain the fuel tank and add fresh fuel
THE ENGINE LACKS POWER OR STALLS	The air filter is dirty	Clean or replace the air filter
	The fuel is old (over 30 days)	Drain the fuel tank and add fresh fuel
	The air filter is dirty	Clean or replace the air filter
	The spark plug is fouled	Replace the spark plug

If further assistance is required, take the unit to a qualified service dealer.



### WARNING!

If the unit strikes or becomes entangled with a foreign object, stop the unit immediately. Check for damage. If damaged, do not restart or operate the unit until it is repaired. Do not operate the unit with loose or damaged. If a blockage is likely to occur, switch off the engine and wait until it has stopped completely. Check that the machine is not damaged. Repair any damage.

# 10. DECLARATION OF CONFORMITY



BUILDER

ZI, 32 rue Aristide Bergès – 31270 Cugnaux - France

Declares that the machinery designated below:

PETROL Blower

Model: FST264T

Serial number: 20221219419-20221219718

Complies with the provisions of the Directive "machinery" 2006/42/EC and regulations  
National transposing it;

Also complies with the following European directives:

EMC Directive 2014/30/EU

RoHS Directive (EU)2015/863 amending 2011/65/EU

Emission directive (EU) 2016/1628 & 2017/656/EU

Noise emission Directive 2000/14/EC and Directive 2005/88/EC

Guarantee sound power level: 105 dB(A)

Measured sound power level: 100.3 dB(A) K=3 dB(A)

Also complies with European standards, national standards and provisions following  
techniques:

EN 15503:2009+A2:2015

EN ISO 12100:2010

EN ISO 14982:2009

Responsible of the technical file: M. Patriarca

Cugnaux, le 27/09/2022

Philippe

A handwritten signature in black ink, appearing to be the name 'Philippe', written over a faint circular stamp or background.

# 11. WARRANTY

The manufacturer guarantees the product against defects in material and workmanship for a period of 2 years from the date of the original purchase. The warranty only applies if the product is for household use. The warranty does not cover breakdowns due to normal wear and tear.

The manufacturer agrees to replace parts identified as defective by the designated distributor. The manufacturer does not accept responsibility for the replacement of the machine, in whole or in part, and/or ensuing damage.

**The warranty does not cover breakdowns due to:**

- insufficient maintenance.
- abnormal assembly, adjustment or operations of the product.
- parts subject to normal wear and tear.

**The warranty does not extend to:**

- shipping and packaging costs.
- using the tool for a purpose other than that for which it was designed.
- the use and maintenance of the machine done in a manner not described in the user manual.

Due to our policy of continuous product improvement, we reserve the right to alter or change specifications without notice. Consequently, the product may be different from the information contained therein, but a modification will be undertaken without notice if it is recognized as an improvement of the preceding characteristic.

**READ THE MANUAL CAREFULLY BEFORE USING THE MACHINE.**

When ordering spare parts, please indicate the part number or code, you can find this in the spare parts list in this manual. Keep the purchase receipt; without it, the warranty is invalid. To help you with your product, we invite you to contact us by phone or via our website:

**+33 (0)9.70.75.30.30**

**<https://services.swap-europe.com/contact>**

You must create a "ticket" via the web platform.

- Register or create your account.
- Indicate the reference of the tool.
- Choose the subject of your request.
- Describe your problem.

Attach these files: invoice or sales receipt, photo of the identification plate (serial number), photo of the part you need (for example: pins on the transformer plug which are broken).



## 12. PRODUCT FAILURE

### WHAT TO DO IF MY MACHINE BREAKS DOWN?

#### **If you bought your product in a store:**

Empty the fuel tank.

Make sure that your machine is complete with all accessories supplied, and clean! If this is not the case, the repairer will refuse the machine.

Go to the store with the complete machine and with the receipt or invoice.

#### **If you bought your product on a website:**

Empty the fuel tank.

Make sure that your machine is complete with all accessories supplied, and clean! If this is not the case, the repairer will refuse the machine.

Create a SWAP-Europe service ticket on the site: <https://services.swap-europe.com> When making the request on SWAP-Europe, you must attach the invoice and the photo of the nameplate (serial number).

Contact the repair station to make sure it is available before dropping off the machine.

Go to the repair station with the complete machine packed, accompanied by the purchase invoice and the station support sheet downloadable after the service request is completed on the SWAP-Europe site

For machines with engine failure from manufacturers BRIGGS & STRATTON, HONDA and RATO, please refer to the following instructions.

Repairs will be done by approved engine manufacturers of these manufacturers, see their site:

<http://www.briggsandstratton.com/eu/fr>

<http://www.honda-engines-eu.com/fr/service-network-page;jsessionid=5EE8456CF39CD572AA2AEEDFD290CDAE>

<https://www.rato-europe.com/it/service-network>

**Please keep your original packaging to allow for after-sales service returns or pack your machine with a similar cardboard box of the same dimensions.**

**For any question concerning our after-sales service you can make a request on our website <https://services.swap-europe.com>**

**Our hotline remains available at +33 (9) 70 75 30 30.**



# 13. WARRANTY EXCLUSIONS

## THE WARRANTY DOES NOT COVER:

Start-up and setting up of the product.

Damage resulting from normal wear and tear of the product.

Damage resulting from improper use of the product.

Damage resulting from assembly or start-up not in accordance with the user manual.

Breakdowns related to carburetion beyond 90 days and fouling of carburetors.

Periodic and standard maintenance events.

Actions of modification and dismantling that directly void the warranty.

Products whose original authentication marking (brand, serial number) has been degraded, altered or withdrawn.

Replacement of consumables.

The use of non-original parts.

Breakage of parts following impacts or projections.

Accessories breakdowns.

Defects and their consequences linked to any external cause.

Loss of components and loss due to insufficient screwing.

Cutting components and any damage related to the loosening of parts.

Overload or overheating.

Poor power supply quality: faulty voltage, voltage error, etc.

Damages resulting from the deprivation of enjoyment of the product during the time necessary for repairs and more generally the costs related to the immobilization of the product.

The costs of a second opinion established by a third party following an estimate by a SWAP-Europe repair station

The use of a product which would show a defect or a breakage which was not the subject of an immediate report and/or repair with the services of SWAP-Europe.

Deterioration linked to transport and storage\*.

Launchers beyond 90 days.

Oil, petrol, grease.

Damages related to the use of non-compliant fuels or lubricants.

\* In accordance with transport legislation, damage related to transport must be declared to carriers within 48 hours maximum after observation by registered letter with acknowledgement of receipt.

This document is a supplement to your notice, a non-exhaustive list.

**Attention:** all orders must be checked in the presence of the delivery person. In case of refusal by the delivery person, it you must simply refuse the delivery and notify your refusal.

**Reminder:** the reserves do not exclude the notification by registered letter with acknowledgement within 72 hours.

### Information:

Thermal devices must be wintered each season (service available on the SWAP-Europe site). Batteries must be charged before being stored.



BUILDER SAS

32 rue Aristide Berges - Z.I. du Casque - 31270 Cugnaux - France.  
MADE IN PRC 2022