

FEIDER

MACHINES

PETROL TILLER

FRTF220

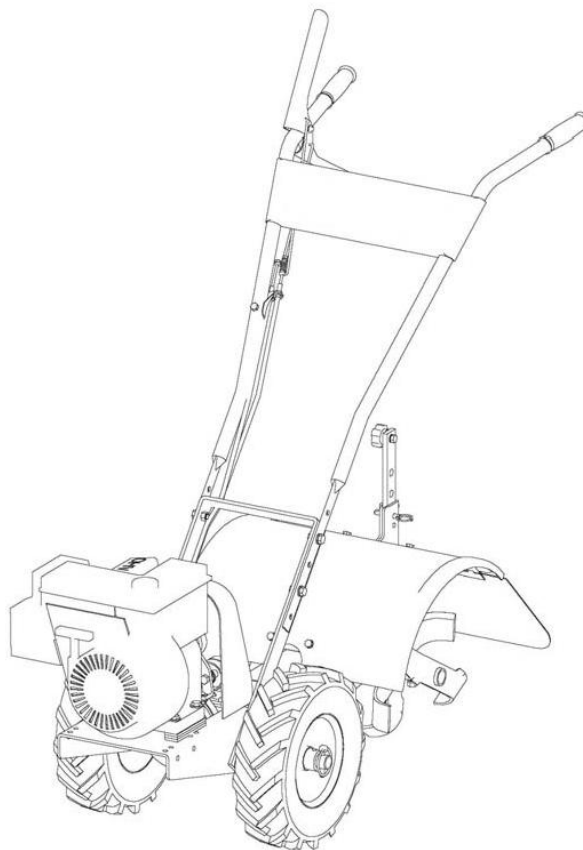

READ THIS INSTRUCTIONS MANUAL BEFORE USING THE TOOL

BUILDER SAS

32, rue Aristide Bergès - ZI 31270 Cugnaux – France



IMPORTANT: Please read and save these instructions. Read through this owner's manual carefully before using product. Protect yourself and others by observing all safety information, warnings and cautions. Failure to comply with instructions could result in personal injury and/or damage to product or property. Please retain instructions for future reference.

Due to continuing improvements, actual product may differ slightly from the product described herein.

SAFETY

This machine shall always be used in accordance with the manufacturer's instructions lay down in the instruction handbook. Keep it for general use.

1) Training

- a) Read the instructions carefully. Be familiar with the controls and the proper use of the equipment
- b) Never allow children or people unfamiliar with these instructions to use the machine. Local regulations can restrict the age of the operator;
- c) Never work while people, especially children, or pets are nearby;
- d) Keep in mind that the operator or user is responsible for accidents or hazards occurring to other people or their property.

2) Preparation

- a) While working, always wear substantial footwear and long trousers. Do not operate the equipment when barefoot or wearing open sandals;
- b) Thoroughly inspect the area where the equipment is to be used and remove all objects which can be thrown up by the machine;
- c) Before using, always visually inspect to see that the tools are not worn out or damaged. Replace worn out or damaged elements and bolts in sets to preserve balance.

3) Operation

- a) Do not operate the tool in a confined space where dangerous carbon monoxide fumes can collect;
- b) Work only in daylight or in good artificial light;
- c) Always be sure of your footing on slopes;
- d) Walk, never run with the machine;
- e) Work across the slopes, never up and down;
- f) Exercise extreme caution when changing direction on slopes;
- g) Do not work on excessively steep slopes;
- h) Use extreme caution when reversing or pulling the machine towards you;
- i) Do not change the motor settings or over speed the engine;

- j) Start the engine carefully according to manufacturer instructions and with feet well away from the tool(s);
- k) Do not put your hands or feet near or under rotating parts;
- l) Never pick up or carry a machine while the engine is running;
- m) Stop the machine when you leave it.

4) **Maintenance and storage**

- a) Keep all nuts, bolts and screws tight to ensure the equipment is in safe working condition;
 - b) Allow the tool to cool before storing in any enclosure;
 - c) Replace worn or damaged parts for safety;
- The machine shall always be used in accordance with the manufacturer's instructions laid down in the instruction handbook
 - The engine shall be stopped when carrying out maintenance and cleaning operations, when changing tools and when being transported by means other than under its own power
 - the adjustable part of the protective device shall be adjusted to the working depth of the tool so that only that part of the working tool that cuts into the soil remains uncovered.
 - start up under normal conditions and, if necessary, for the auxiliary or secondary starting device
 - the machine should only be operated by suitably trained persons

SAFETY DECALS

This rototiller unit has been designed and manufactured to provide you with the safety and reliability you would expect from an industry leader in outdoor power equipment manufacturing.

Although reading this manual and the safety instructions it contains will provide you with the necessary basic knowledge to operated this equipment safely and effectively, we have placed several safety labels on the tiller to remind you of this important information while you are operating the unit.

These important safety labels are illustrated below, and are shown here to help familiarize you with the location and content of the safety messages you will see as you perform normal tilling operations. Please review these labels now. If you have any questions regarding their meaning or how to comply with these instructions, reread the complete safety instruction text on the preceding pages, or contact your local dealer.

Should any of the safety labels become unreadable because of being worn, faded, or otherwise damaged during the use of your tiller, please use the part number information provided to order a replacement label from your local authorized dealer.

The safety labels are easily applied, and will act as a constant visual reminder to you, and others who may use the equipment. Follow the safety instructions necessary for safe, effective operation of your rototiller.

<p align="center">⚠ WARNING</p> <p align="center">AVOID SERIOUS INJURY</p> <ul style="list-style-type: none"> • Read operator's manual(s) before operating. • Know the location and function of all controls. • Keep all shields and guards in place and working while running. • Never allow children to operate tiller. • Dress appropriately—wear sturdy footwear. • Carefully inspect area to be tilled—remove large rocks and other foreign objects. • DO NOT till above underground electric, water, gas, or other utility lines and pipes. • STOP THE ENGINE AND DISCONNECT THE SPARK PLUG WIRE before removing debris or servicing unit. • When leaving the operating position for any reason: <ul style="list-style-type: none"> — shut off the engine. — wait for all moving parts to stop. 	<p align="center">⚠ WARNING</p> <p align="center">WHEELS ACT AS BRAKES</p> <ul style="list-style-type: none"> • Never start or operate tiller with wheels in the Free Wheel position, Make sure wheel lockouts are engaged through wheel hubs and axle. • Wheels act as brakes to keep the tiller at a controlled speed, Disengage wheel lockouts ONLY when engine is stopped. <p align="center">OPERATION</p> <p align="center">REFER TO OPERATOR'S MANUAL FOR DETAILED OPERATING INSTRUCTIONS TO START:</p> <ol style="list-style-type: none"> 1. Release drive control levers to neutral position. 2. Lower the drag stake so that tines do not touch the ground. 3. Check position of wheels and wheel lockouts. 4. Slide choke control to choke position. 5. Move throttle control lever to fast position. 6. Pull starter rope.
---	---

⚠ DANGER

AVOID INJURY FROM ROTATING TINES!
Keep hands, feet, and clothing away.

- Tines rotate when tiller is engaged in forward or reverse.
- Tines and wheels rotate when drive control levers are pulled down.
- In reverse, tines and wheels rotate when the reverse handle is pulled back toward the operator.
- Releasing the drive control levers to the neutral position stops the wheels and tines.

⚠ WARNING

DO NOT START ENGINE UNLESS BELT COVER IS ATTACHED. KEEP HANDS, FEET, AND CLOTHING AWAY FROM MOVING BELTS AND PULLEYS. FAILURE TO COMPLY COULD RESULT IN INJURY. SEE OWNER'S MANUAL FOR FULL SAFETY INSTRUCTIONS.

⚠ WARNING

	Read and follow Operating Instructions before running engine.
	Gasoline is flammable. Allow engine to cool at least 2 minutes before refueling.
	Engines emit carbon monoxide, DO NOT run in enclosed area.
	Muffler area temperature may exceed 150°F. Do not touch hot parts.



Read instructions manual



Rotating blades in operation - Keep feet away from the cutting element

FORWARD

REVERSE

ASSEMBLY INSTRUCTIONS

The rototiller comes fully assembled except for a few parts. The following instructions will help you assemble and adjust the tiller's depth regulator, cable tension, and handlebar height. You will need two 9/16" wrenches to complete the assembly.

STEP 1 Install the Depth Regulator

1. Install the depth regulator into the top of the depth regulator Bracket with handle facing rearward.
2. Insert depth regulator pin through depth regulator bracket and top hole of depth regulator-tines should clear the ground.

IMPORTANT

THE RIGHT AND LEFT SIDES OF YOUR ROTOTILLER ARE DETERMINED FROM THE OPERATING POSITION AS YOU FACE THE DIRECTION OF FORWARD TRAVEL.

ENGINE IS SHIPPED FROM FACTORY WITHOUT OIL. YOU MUST ADD ENGINE OIL BEFORE STARTING ENGINE.

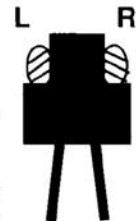

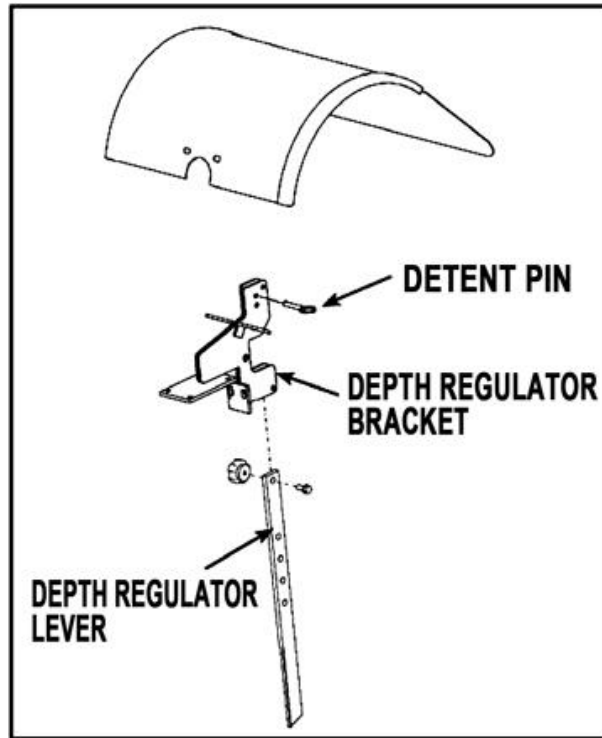

STEP 2 Attach ex-arm-rest stems to the Tiller

1. The ex-arm-rest stems on outside of the Transmission cover and align the lower boles.
2. Insert one 3/8"-16x 1" bolt for each side in lower holes.
3. Start 3/8"-16 nuts on each bolt.
4. Insert one 3/8"-16x 1" bolt for each side in Upper holes at desired handlebar height.
5. Tighten all the nuts.

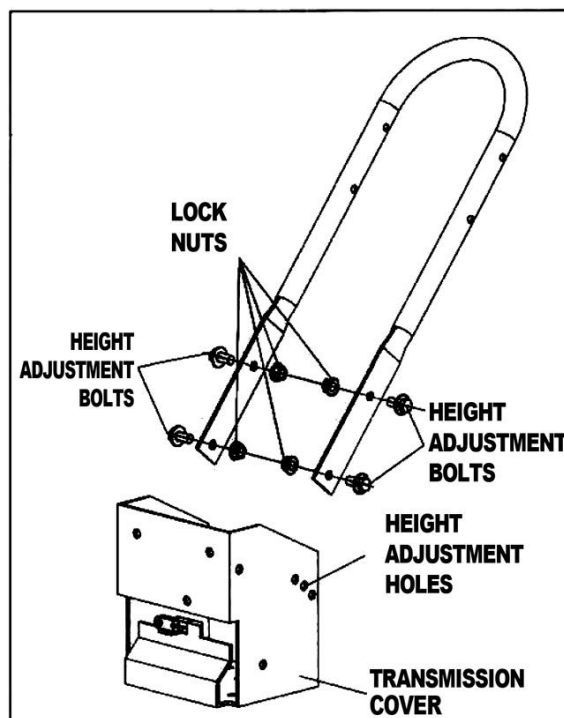

STEP 3: Attach handle bar to the Tiller

1. Insert four fastness bolts for each side in every holes.
2. Start fastness nuts on each bolt.
3. Tighten all the nuts.

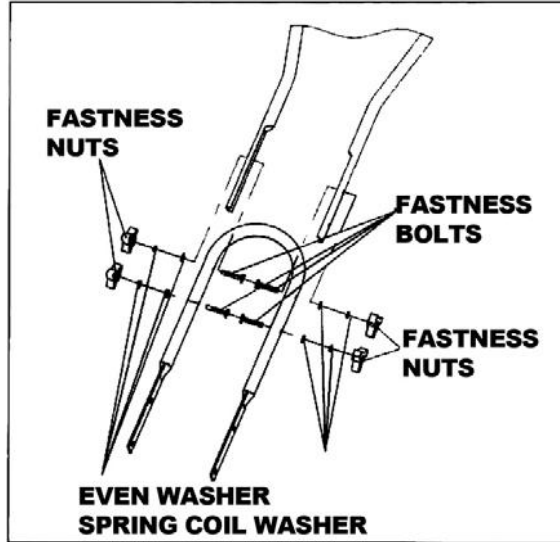

STEP4 Fill Engine Crankcase

IMPORTANT

Engine is shipped from factory without oil. Engine oil must be added before starting engine.

1. Add oil according to engine manual. Do not overfill. Use clean, high quality detergent oils. Do not mix oil with gasoline. Oil level must be full. Check the oil level by removing oil fill plug.
2. Always check oil level before starting engine. Refer to engine manual for capacity and type of oil to use.

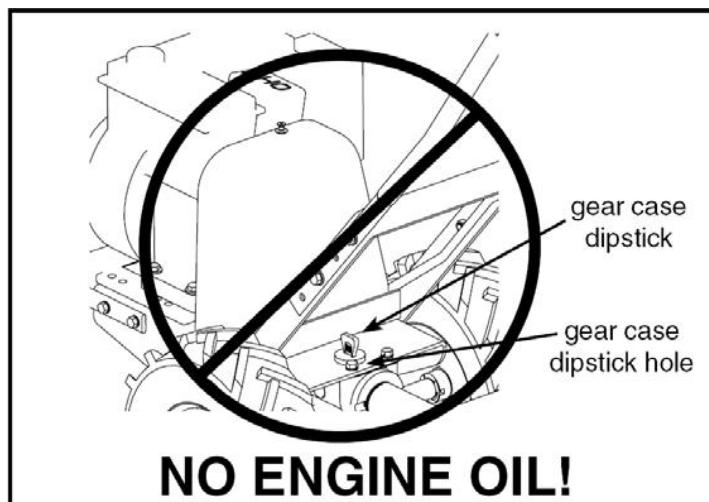

OPERATION

PRE-START INSPECTION

1. Make sure all safety guards are in place and all nuts and bolts are secure.
2. Check oil level in engine crankcase. See your engine manual for procedure and specifications.
3. Inspect air cleaner for cleanliness. See your engine manual for procedure.
4. Check the fuel supply. Fill the fuel tank no closer than 1 inch from top of tank to provide space for expansion. See your engine manual for fuel recommendations.
5. Be sure spark plug wire is attached and spark plug is tightened securely.
6. Check position of wheels and wheel lockouts.
7. Check depth regulator lever position.
8. Examine underneath and around engine for signs of oil or fuel leaks.
9. Inspect fuel hoses for tightness and fuel seepage.
10. Look for signs of engine damage.
11. Remove excessive debris from muffler area and recoil starter.

START- UP

The controls required to start and run the rototiller are located on the engine and are marked “choke” and “Throttle”.

A more detailed description of engine operation and all related precautions and procedures can be found in the engine manufacturer’s manual that accompanies each tiller.

COLD STARTS

1. Move choke lever to full choke position.
2. Move throttle lever to “start”.
3. Pull starting rope out slowly one time and allow to return normally.

CAUTION

PLEASE DO NOT START YOUR TILLER UNTIL YOU HAVE READ THE MANUAL THAT CAME WITH YOUR ENGINE, AND THE SECTIONS IN THIS MANUAL TITLED CONTROLS, ADJUSTMENTS AND SAFETY. IF YOU HAVE READ THESE, FOLLOW THE STEPS BELOW TO START YOUR TILLER. ALWAYS PERFORM THIS PRE-START CHECKLIST BEFORE STARTING THE ENGINE.

WARNING

GASOLINE IS HIGHLY FLAMMABLE AND MUST BE HANDLED WITH CARE. NEVER FILL THE TANK WHEN THE ENGINE IS HOT OR RUNNING. ALWAYS MOVE OUTDOORS TO FILL THE TANK.

WHEELS MUST ALWAYS BE LOCKED IN THE TILLING POSITION WHEN ENGINE IS RUNNING. DO NOT OPERATE THE TILLER WITH THE WHEEL LOCKOUTS UNLOCKED. ALWAYS SET THE WHEELS IN TILLING POSITION BEFORE STARTING ENGINE.

ALWAYS PUT THE DEPTH REGULATOR LEVER IN THE TRANSPORT POSITION BEFORE STARTING ENGINE. TINES SHOULD CLEAR THE GROUND.

IMPORTANT

ENGINE IS SHIPPED FROM FACTORY WITHOUT OIL. YOU MUST ADD ENGINE OIL BEFORE STARTING ENGINE.

DANGER

ALWAYS KEEP HANDS AND FEET CLEAR OF ROTATING MACHINE PARTS.

4. Pull starting rope out rapidly, and allow rope to return normally.

When engine starts, gradually move choke lever to “no choke” position and increase throttle speed.

RESTARTING A WARM ENGINE

Restarting an engine that is already warm from previous running does not normally require use of the choke.

1. Move throttle lever to “start” position.
2. Pull starting rope out rapidly until engine starts. Allow rope to return normally. Repeat until engine starts.
3. Adjust throttle speed to “high” for best tiller action.

IDLE SPEED

Use the “low” position on the throttle lever to reduce stress on the engine when tilling is not being performed. Lowering the engine speed to “idle” will help extend the life of the motor, as well as conserve fuel and reduce the noise level of the equipment.

OPERATING SPEED

For normal tilling, set the throttle lever to “fast”.

SHUTTING DOWN

To stop the engine at any time, turn engine ON/OFF switch to the off position. To stop wheels and tines at any time, release drive safety control levers to neutral position.

TILLING

1. Adjust the depth regulator lever to desired tilling depth.

NOTE: Raise depth regulator lever up one hole at a time, testing tiller operation after each raise. Raising depth regulator lever too high can result in loss of control of tiller!

2. Move the throttle control to **fast**.
3. Place the tiller in **forward** by pushing down on the drive safety control lever(**FORWARD**)--this will engage the wheels and tines.

⚠ WARNING

TEMPERATURE OF MUFFLER AND NEARBY AREAS MAY EXCEED 150° F. AVOID THESE AREAS.

DO NOT MOVE CHOKE CONTROL TO CHOKE TO STOP ENGINE. BACKFIRE OR ENGINE DAMAGE MAY OCCUR.

TO STOP WHEELS AND TINES AT ANY TIME, RELEASE DRIVE SAFETY CONTROL LEVERS TO NEUTRAL POSITION.

ALWAYS RELEASE DRIVE SAFETY CONTROL LEVERS TO NEUTRAL POSITION BEFORE ADJUSTING THE DEPTH OF THE REGULATOR LEVER.

⚠ DANGER

ENGINE AND SURROUNDING PARTS BECOME EXTREMELY HOT DURING NORMAL USE AND WILL CAUSE SERIOUS BURN INJURIES IF TOUCHED BEFORE THE ENGINE HAS COOLED.

ALLOW ENGINE TO COOL COMPLETELY BEFORE TOUCHING THESE HOT SURFACES.

IMPORTANT

PRACTICE OPERATING THE CONTROLS AND TILLER WITH TINES OUT OF GROUND BEFORE BEGINNING TO TILL. IT IS IMPORTANT THAT YOU KNOW HOW TO USE THE TILLER PROPERLY, KEEP CONTROL AT ALL TIMES, STOP THE TINES AND WHEELS FROM TURNING, AND STOP THE ENGINE IF NECESSARY. IF YOU DO NOT KNOW HOW TO DO THESE THINGS, READ THE CONTROLS, ADJUSTMENTS AND SAFETY SECTIONS BEFORE PROCEEDING.

NOTE: You can slow the tiller's forward advance at any time by putting slight downward pressure on the handlebars. You can stop the tiller by releasing the drive safety control levers to the neutral position.

DRIVE SAFETY CONTROL LEVERS

FORWARD LEVER

Engages wheels and tines into forward.

Pushing down the drive safety control lever(**FORWARD**) toward the handlebar engages the wheels and tines. Releasing the lever stops the wheels and tines and brings the tiller to a complete stop.

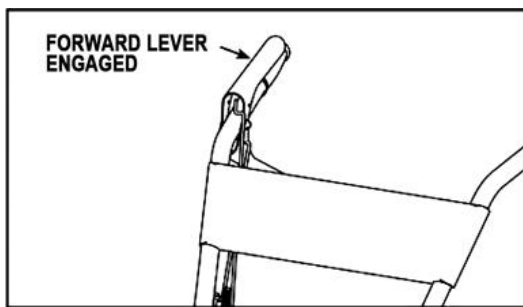

CAUTION

DO NOT OPERATE BOTH "FORWARD" AND "REVERSE" DRIVE SAFETY CONTROL LEVERS AT THE SAME TIME.

THIS INFORMATION IS PROVIDED HERE ONLY TO INTRODUCE THE CONTROLS. DO NOT START THE ENGINE AT THIS TIME. STARTING AND OPERATING INSTRUCTIONS ARE GIVEN ON PAGE ???. PLEASE READ THIS SECTION AND ALL OPERATING AND SAFETY INSTRUCTIONS BEFORE STARTING YOUR TILLER.

- AS A SAFETY PRECAUTION, THE DRIVE SAFETY CONTROL LEVERS WILL NOT LOCK IN THE FORWARD OR REVERSE POSITION.
- AS A SAFETY PRECAUTION, THE REVERSE DRIVE SAFETY CONTROL LEVER WILL NOT LOCK IN REVERSE.
- TO STOP THE WHEELS AND TINES AT ANY TIME RELEASE THE DRIVE SAFETY CONTROL LEVERS OR RELEASE THE REVERSE HANDLE.
- DO NOT OPERATE BOTH THE REVERSE AND FORWARD DRIVE SAFETY CONTROL LEVERS AT THE SAME TIME.

REVERSE LEVER

Engages wheels and tines into reverse.

Pulling the drive safety control lever(**REVERSE**) toward the handlebar reverses tiller. Releasing the lever stops the wheels and tines.

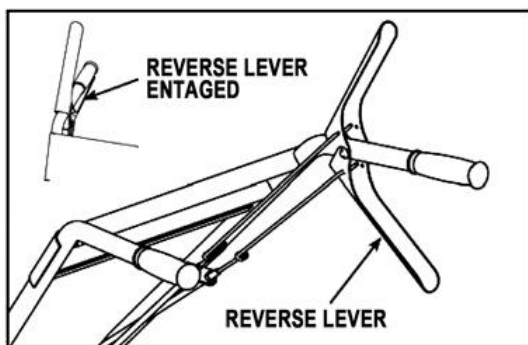

ADJUSTMENTS

WARNING

ENGINE SHOULD BE OFF BEFORE ADJUSTING ANY CONTROLS.

EXTREME CAUTION SHOULD BE USED WHEN OPERATING ROTOTILLER IN THE REVERSE DIRECTION.



WHEEL LOCK PINS

Place wheels in tilling position.

1. Remove lock pin. Align hole in axle with hole in wheel hub.
2. Insert lock pin through holes, fold lock pin ring to secure pin to axle.
3. Firmly lock wheel and axle together before tilling.
4. Repeat for other wheel.

NOTE: Always have both wheel lock pins in or out. Do not operate tiller with only one wheel locked.

To place wheels in free-wheel position.

1. Remove lock pin. Slide wheel inward toward machine.
2. Insert pin in axle only.
3. Wheel should turn freely on axle.

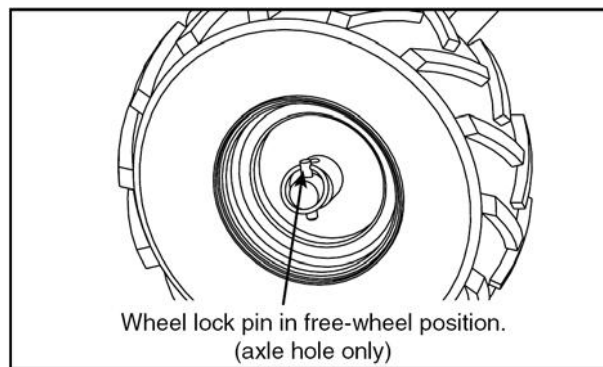

HANDLEBAR HEIGHT ADJUSTMENT

Adjust handlebar height.

The ideal height of the handlebar varies with operator height and the depth of tilling. To adjust handlebar height:

1. Unscrew nuts and remove top and bottom bolts on each side.
2. Align handlebar to desired holes on the lower handlebar mount.
3. Install bolts and nuts. Retighten.

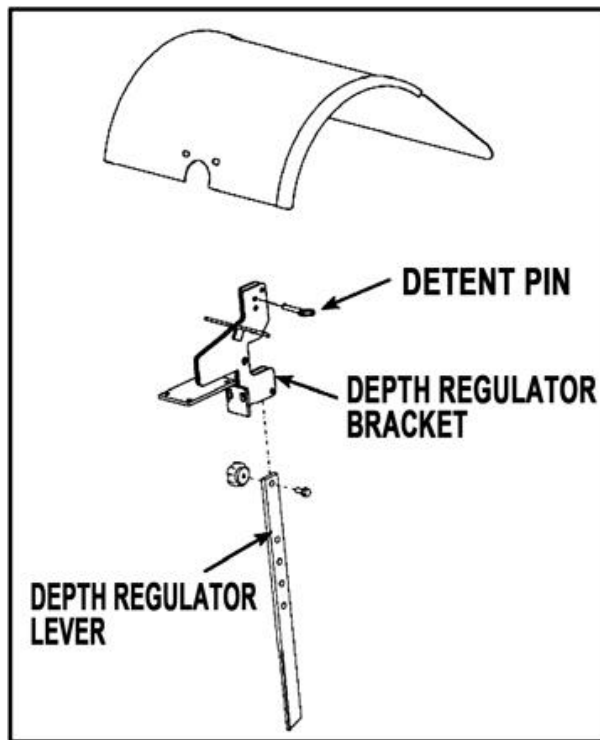

DEPTH REGULATOR LEVER

Tilling depth is controlled by the height of the depth regulator lever. To adjust tilling depth:

1. Remove detent pin.
2. Raise the depth regulator lever to position tines at chosen tilling depth.
3. Align hole in depth regulator lever with hole in depth regulator bracket and replace detent pin.

Depth Regulator Lever Down = Shallower tilling.

Place the detent pin in the top hole of the depth regulator lever for shallowest tilling.

Depth Regulator Lever Up = Deeper tilling.

Place the detent pin in the bottom hole of the depth regulator lever for deepest tilling.

WARNING

DO NOT ADJUST TILLING DEPTH UNLESS DRIVE SAFETY CONTROL LEVERS ARE RELEASED TO NEUTRAL POSITION.

ALWAYS SET THE DEPTH REGULATOR LEVER IN THE TRANSPORT POSITION BEFORE STARTING ENGINE, THAT IS, PLACE THE DETENT PIN IN THE HIGHEST HOLE OF THE DEPTH REGULATOR LEVER.

BELT TENSION ADJUSTMENT

Proper belt tension is critical to good performance. After 1/2 hour of operation, all cables may have to be adjusted due to initial stretch. Thereafter, check tension after every 2 hours of operation.

To increase belt tension:

1. Loosen upper jam nut. Turn nut up cable in 1/8" increments.
2. Tighten lower jam nut.
3. check adjustment.

This procedure can be repeated until conduit adjustment bolts are fully adjusted. If no more adjustment can be made, belt may have to be replaced.

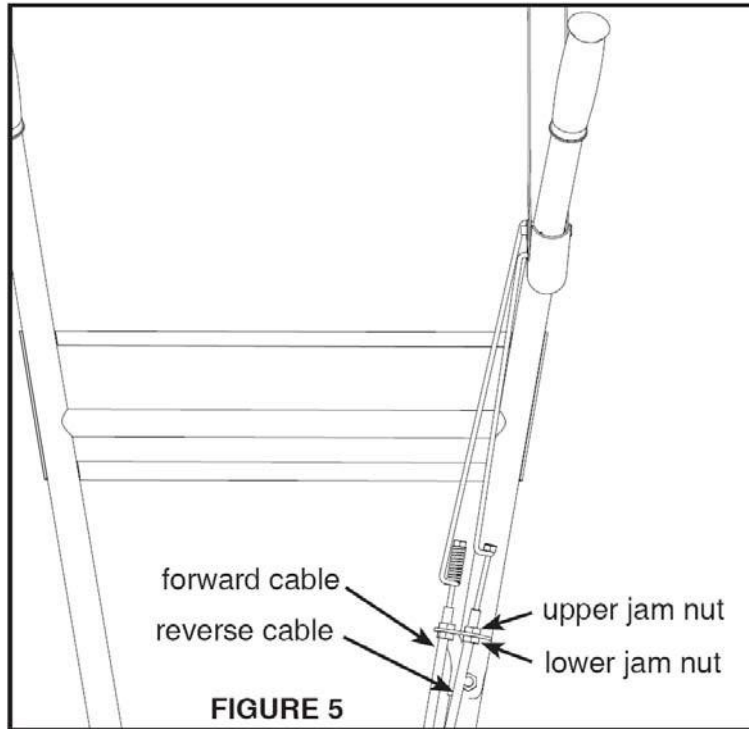

TILLING TIPS

The key to successful tilling is to begin with a shallow cut on the first pass, and then work an inch or two deeper on each successive pass.

- Tilling depth will vary with ground conditions.
- When beginning to till in unbroken ground or in extremely hard soil, set the detent pin in the highest hole of the drag stake (follow instructions under Tilling section). This will allow for shallow tilling. With the drag stake

in this position, make several light passes over the area to be tilled. Reset for deeper depths with successive passes.

- If tiller jumps or skids uncontrollably, lower the drag stake by placing the detent pin in a higher hole. This will allow for shallower tilling. Hold firmly to the handlebars to control sudden lurches.

⚠ WARNING
EXTREME CAUTION MUST BE TAKEN IN SELECTING TILLING DEPTH. IF YOU ATTEMPT TO TILL TOO DEEPLY FOR SOIL CONDITIONS, THAT IS, WITH THE DRAG STAKE IN TOO HIGH A POSITION, LOSS OF CONTROL COULD RESULT.
IF REMOVING MATERIAL FROM THE TINES BY HAND, STOP ENGINE AND REMOVE SPARK PLUG WIRE FIRST.

- If weeds, tall grasses, vines, or other materials clog or jam the tines, reverse the tiller to unwind vegetation.

Immediately release the drive control levers if the tines jam or you strike a foreign object. With drive control levers in neutral position, push throttle control to stop position to stop the engine. Disengage the spark plug wire. When tines have stopped, remove foreign objects and check for damage.

CULTIVATING TIPS

If you plan to use your tiller for cultivating:

- Plant rows on 20" - 22" centers for ease of turning.
- Set the depth regulator lever with the detent pin in one of the higher holes. This will allow for shallow cultivation necessary to turn over weeds, and break up and aerate the soil.

MAINTENANCE AND STORAGE

MAINTENANCE

Keeping the tiller in top running condition will prolong the tiller's life, and help it obtain optimum performance whenever you wish to till your garden.

To help you properly care for the rototiller, the following pages include a maintenance schedule, routine inspection procedures, and simple maintenance procedures using basic hand tools. Other service tasks that are more difficult, or require special tools, are best handled by professionals and are normally performed by a qualified mechanic.

- Good maintenance is your responsibility, poor maintenance is an invitation to trouble.

Follow good shop practices.

Keep service area clean and dry.

Be sure electrical outlets and tools are properly grounded.

Use adequate light for the job at hand.

- Make sure the engine is off before you begin any maintenance or repairs. This will eliminate several potential hazards:

Carbon monoxide poisoning from engine exhaust.

Be sure there is adequate ventilation whenever you operate the engine. Never operate the engine in a closed building.

Burns from hot parts.

Let the engine and exhaust system cool before touching.

Injury from moving parts.

Do not run the engine unless instructed to do so.

- Read the instructions before you begin, and make sure you have the tools and skills required.
- To reduce the possibility of fire or explosion, be careful when working around gasoline. Use only a nonflammable solvent, not gasoline, to clean parts. Keep cigarettes, sparks and flames away from all fuel-related parts.
- Always use personal protection devices such as eye, hand and hearing protectors when performing any service or maintenance.
- Frequently check tiller tines. They should be free of nicks and cracks and securely fastened in place.

Periodically tighten all bolts, nuts, screws, and check that all pins are properly installed to make certain unit is safe to operate.

- When completing maintenance or service, make sure all safety guards and devices are installed before using the rototiller.
- Where replacement parts are necessary for periodic maintenance and servicing, use only new, original replacement parts or their equivalents for repair and replacement to restore your equipment to original specifications.
- The manufacturer and/or distributor will not be responsible for injuries or damages caused by use of unapproved parts and/or accessories.
- A first aid kit should be kept readily accessible while performing maintenance on this equipment.

MAINTENANCE SCHEDULE

Your rototiller has been designed and produced by the industry's leading manufacturer of outdoor power equipment to provide you with years of reliable operation.

Keeping your tiller in top running condition will prolong its life, and help you obtain optimum performance.

Please read this normal care schedule, and note the recommended care operating intervals to extend the life of your unit.

Maintenance Operation		Each Use	First Month or 20 Hours	Every 3months or 50Hours	Every 6months or 100Hours	Every year or 300Hours
Drive Belt Tension	Check	√				
	Change	√				

Engine oil	Check level	√				
	Change		√		√	
Air filter	Check	√				
	Clean			√(1)	√(1)	
	Replace					√
Tiller Transmission Grease	Check	√				
	Replace			√		
Tire Pressure	Check	√				
Tine Shaft	Clean	√				
Wheel Axle Shaft	Lubricate			√		

1) Service more frequently when used in dusty areas.

SERVICING THE ROTOTILLER

The following information will help you make the necessary checks and perform the procedures required to follow the normal care recommendations made for your rototiller unit.

If you prefer, your local authorized dealer can make these checks and perform the required procedures for you.

CHANGE FORWARD/REVERSE BELT

1. Turn off engine. Engine must be cool.
2. Remove spark plug wire and secure from spark plug.
3. Remove belt guard.
 - remove the forward belt from the forward engine pulley:
 - gently pull the engine recoil rope to rotate the pulley.
 - with the pulley turning, force the forward belt out of the V-groove.
 - slide the belt free of the engine pulley.

⚠ WARNING

To prevent accidental starting:



Engine must be turned off and cool, and spark plug wire must be removed and secured from spark plug before checking and adjusting engine or equipment.

⚠ CAUTION

DO NOT OPERATE TILLER BEFORE READING THE ENGINE MANUAL PROVIDED IN THE PARTS PACKET.

- pull the forward belt down and out of the way.

• remove the reverse belt from the reverse engine pulley:

- gently pull the engine recoil rope to rotate the pulley.

- with the pulley turning, force the reverse belt out of the V-groove.

- slide the belt free of engine pulleys and reverse belt guides.

- pull belt down and away from transmission pulley.

• install new reverse belt:

- thread belt up from bottom.

- place belt around transmission pulley in groove.

- place belt under reverse belt guides.

- gently pull engine recoil rope while forcing the belt over the edge of the engine pulley into the V-groove.

• install new forward belt:

- place forward belt in transmission pulley groove.

- gently pull the engine recoil rope to rotate the pulley while forcing the forward belt into the V-groove.

4. Replace belt guard.

5. Attach spark plug wire.

ENGINE MAINTENANCE

Refer to the engine manual included in your parts packet for information on engine maintenance. Your engine manual provides detailed information and a maintenance schedule for performing the following tasks:

1. Check oil level before each use or after every 8 hours of operation.

2. Change oil after first 5-8 hours of operation. change oil while engine is warm. Refill with new oil of recommended grade.

4. Check spark plug yearly or every 100 hours of operation.

WARNING

TEMPERATURE OF MUFFLER AND NEAR BY AREAS MAY EXCEED 150° F. AVOID THESE AREAS.

IMPORTANT

ENGINE CAN OVERHEAT AND BECOME DAMAGED IF DEBRIS BLOCKS THE COOLING SYSTEM OR ROTATING SCREEN.

NEVER RUN ENGINE WITHOUT COMPLETE AIR CLEANER INSTALLED ON ENGINE.

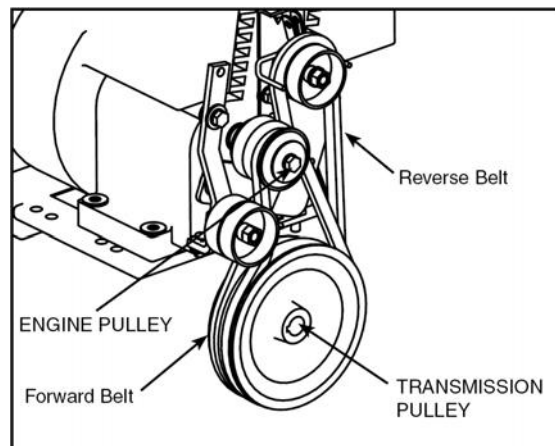

5. Service air cleaner.
6. Keep engine and parts clean.
7. Check engine and equipment often for loose nuts and bolts, keep these items tightened.

CHECK OR FILL ENGINE CRANKCASE

1. Add oil according to engine manual. **Do not overfill.** Use a clean, high quality detergent oil. **Do not mix oil with gasoline.** Oil level must be full. check the oil level by removing oil fill plug. Oil level should be up to the bottom of the fill plug opening.

IMPORTANT

ENGINE IS SHIPPED FROM FACTORY WITHOUT OIL. YOU MUST ADD ENGINE OIL BEFORE STARTING ENGINE.

2. Always check oil level before starting engine. Refer to engine manual for capacity and type of oil to use.

CHECK TILLER TRANSMISSION GREASE

Check the grease level annually. To check the grease level:

1. Move tiller to level ground.
2. Remove grease level dipstick located between the handlebar mounts on the engine mount. If the grease level couldn't touch the dipstick, pls fill the grease.
3. Replace grease level dipstick in the filler hole.

IMPORTANT

TILLER TRANSMISSION IS SHIPPED FROM FACTORY WITH THE PROPER AMOUNT OF LIQUID GREASE.

WHEN REPLACING GREASE, THE TILLER TRANSMISSION HOLDS 18-22 OUNCES. DO NOT OVERFILL.

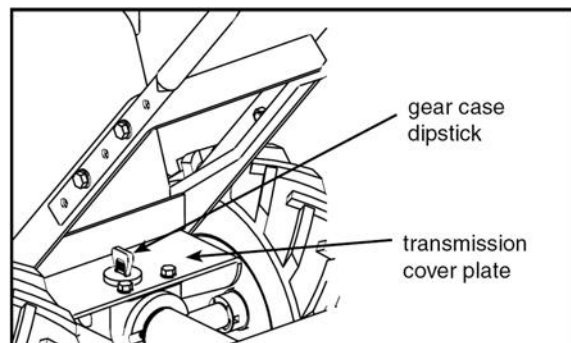

4. Note that the front wheel transmission and rear tine transmission are one common reservoir. When you add to the front transmission, you must wait a short period of time for the grease to flow rearward and equalize in both front and rear. The dipstick will read correctly on level ground for both gear units.

CHECK TIRE PRESSURE

Recommended tire pressure is 20 PSI. If tires do not have equal pressure, tiller will pull to one side.

LUBRICATION

Proper lubrication of moving mechanical parts is critical for proper care and maintenance. Oil the moving parts shown at 10 hour intervals using a 30 weight oil.

CLEAN TINE AXLE SHAFT

1. Turn off engine. Engine must be cool.
2. Remove spark plug wire and secure from spark plug.
3. Tip the tiller forward. Block the tiller in position so that it rests on the engine mount and the tines are exposed.
4. Remove all vegetation, string, wire, and other material that may have accumulated on the axle between the inside set of tines and the seal on the transmission housing.
5. Tip the tiller back to a level position.
6. Replace spark plug wire.

STORAGE

PREPARE FOR STORAGE

Follow the steps below to prepare your tiller for storage. Read your engine manual for detailed instructions on preparing the engine for storage.

1. Protect wheels and axles from rust:
 - Remove lockpin and slide wheel off hub.
 - Coat the axles lightly with axle grease.
 - Slide wheel back on hub and insert lock pin.



WARNING

DO NOT STORE TILLER IN AN UNVENTILATED AREA WHERE FUEL FUMES MAY REACH FLAME, SPARKS, PILOT LIGHTS OR AN IGNITED OBJECT. DRAIN FUEL OUTDOORS AWAY FROM ANY IGNITION SOURCES. USE ONLY APPROVED FUEL CONTAINERS.

2. Drain fuel system completely following engine manufacturer's instructions or add fuel stabilizer to prevent fuel from gumming up during extended storage period.
3. While engine is still warm, drain the oil from the engine. Refill with fresh oil of the recommended grade.
4. Clean external surfaces, engine and cooling fan.
5. Remove spark plug, pour one ounce of SAE 30 oil into spark plug hole.
6. Plug hole and pull starter cord slowly to distribute oil evenly in cylinder head area.
7. Reinstall spark plug.
8. Transport unit to a suitable storage location. If you have chosen to use a fuel stabilizer and have not drained the fuel system, follow all safety instructions storage precautions in this manual to prevent the possibility of fire from the ignition of gasoline fumes. Remember, gasoline fumes can travel to distant sources of ignition and ignite, causing risk of explosion and fire.

9. If there is any possibility of unauthorized use or tampering, remove the spark plug and store it in a safe place before storing the rototiller unit. Be sure to plug the spark plug hole to prevent foreign material from entering.

TROUBLESHOOTING AND REPAIR

TROUBLESHOOTING GUIDE

While normal care and routine maintenance will extend the life of your rototiller, prolonged or constant use may eventually require that service be performed to allow it to continue operating properly. The troubleshooting guide below lists the most common problems, causes and remedies.

PROBLEM	REMEDY/ACTION
Engine will not start	<ul style="list-style-type: none"> • Add gas to gas tank. • Connect spark plug wire to spark plug • Throttle must be positioned at choke for a cold start
Engine runs rough, foods during operation	<ul style="list-style-type: none"> • Clean or replace air cleaner
Engine is hard to start	<ul style="list-style-type: none"> • Drain old fuel and replace with fresh. Use gas stabilizer at end of season • Make sure spark plug wire is securely attached to spark plug • Drive safety control levers must be released to neutral position to start the engine
Engine misses or lacks power	<ul style="list-style-type: none"> • Raise the tines for shallow tilling by lowering the depth regulator lever • Remove and clean fuel tank • Clean or replace air cleaner • Improper carburetor adjustment, take to authorized engine service center • Replace spark plug and adjust gap • Drain and refill gas tank and carburetor
Engine will not stop when throttle control is positioned at stop	<ul style="list-style-type: none"> • See engine manual to check and adjust throttle linkage

Tiller moves forward during starting	<ul style="list-style-type: none"> • Drive safety control levers must be released to neutral position to start the engine
Tiller is difficult to control when tilling (machine jumps or lurches forward)	<ul style="list-style-type: none"> • Lock wheels in tilling position • Raise the tines for shallower tilling by lowering the depth regulator lever

PROBLEM	REMEDY/ACTION
Tines turn, wheels do not turn	<ul style="list-style-type: none"> • Lock wheels in tilling position • Internal transmission failure, see your dealer
Tines turn, wheels turn, tiller does not move	<ul style="list-style-type: none"> • Lower the tines for deeper tilling by raising the depth regulator lever
Belts squeal in neutral and/or reverse	<ul style="list-style-type: none"> • Adjust forward belt guide: <ul style="list-style-type: none"> - turn engine off and allow muffler to cool - disconnect spark plug wire and secure from spark plug - remove belt guard - pull down on drive safety control levers - manually bend forward belt guide so there is 1/16 inch or less clearance between belt guide and belt - replace belt guard and spark plug wire
Belts squeal in forward operation	<ul style="list-style-type: none"> • Adjust tabs on the reverse belt guide <ul style="list-style-type: none"> - turn engine off and allow muffler to cool - disconnect spark plug wire and secure from spark plug - release drive safety control levers to neutral position - remove belt guard - adjust tabs of reverse belt guide: <ul style="list-style-type: none"> while drive safety control levers are released, bend metal tabs on reverse belt guide to 1/64 inch or less clearance from reverse belt - replace belt guard and spark plug wire

Excessive heat build up in transmission/tine area during tilling	<ul style="list-style-type: none"> • Remove vegetation by following instructions in clean Tine Axle Shaft of Normal care section. FOLLOW ALL SAFETY INSTRUCTIONS • Check transmission fluid and fill if needed
--	--

TECHNICAL DIAGRAM

Power	4.1kW
Tilling Scope	480mm
Tilling Depth	175~350mm
Gear Shifting	0, 1, -1
Engine Type	OHV 4-stroke
Starting System	Recoil
Displacement	212cm ³
Engine Speed	3600/min
Fuel Volume	3.6 L
Oil Volume	0.6 L
Fuel Type	Unleaded Gasoline
Vibration	<p>Left: 7.48 m/s²</p> <p>Right: 7.48 m/s²</p> <p>Uncertainty K: 1.5 m/s²</p>
Noise emission:	<p>Sound pressure level: 84.3 dB(A)</p> <p>Sound power level:99.8 dB(A)</p> <p>Guarantee sound power level: 102 dB(A)</p> <p>Uncertainty K=2dB(A)</p>

Déclaration CE de conformité



Déclaration CE de conformité

BUILDER SAS

32 rue Aristide Berges -Z1 31270 Cugnaux - France
Tel: +33 (0) 5.34.508.508 Fax: +33 (0) 5.34.508.509

Déclare que la machine désignée ci-dessous

PETROL TILLER

FRTF220

S/N: 20201127614-20201127683

Est conforme aux dispositions de la directive « machine » 2006/42/CE et aux réglementations nationales la transposant ;

Est également conforme aux dispositions des directives européennes suivantes :
A la Directive CEM 2014/30/UE

Emission directive (EU) 2016/1628 & 2018/989/EU
Directive 2000/14/CE Annex VI, 2005/88/EC

Guarantee sound power level: 102dB(A)

Est également conforme aux normes européennes, aux normes nationales et aux dispositions techniques suivantes :

EN709:1997/A4: 2009

EN55012:2007/A1:2009

EN61000-6-1:2007

.Cugnaux, 25/09/2020

Philippe MARIE / PDG

Responsable du dossier technique : Julia Zou

WARRANTY



WARRANTY

The manufacturer guarantees the product against defects in material and workmanship for a period of 2 years from the date of the original purchase. The warranty only applies if the product is for household use. The warranty does not cover breakdowns due to normal wear and tear.

The manufacturer agrees to replace parts identified as defective by the designated distributor. The manufacturer does not accept responsibility for the replacement of the machine, in whole or in part, and/or ensuing damage.

The warranty does not cover breakdowns due to:

- insufficient maintenance.
- abnormal assembly, adjustment or operations of the product.
- parts subject to normal wear and tear.

The warranty does not extend to:

- shipping and packaging costs.
- using the tool for a purpose other than that for which it was designed.
- the use and maintenance of the machine done in a manner not described in the user manual.

Due to our policy of continuous product improvement, we reserve the right to alter or change specifications without notice. Consequently, the product may be different from the information contained therein, but a modification will be undertaken without notice if it is recognized as an improvement of the preceding characteristic.

READ THE MANUAL CAREFULLY BEFORE USING THE MACHINE.

When ordering spare parts, please indicate the part number or code, you can find this in the spare parts list in this manual. Keep the purchase receipt; without it, the warranty is invalid. To help you with your product, we invite you to contact us by phone or via our website:

- **+33 (0)9.70.75.30.30**
- **<https://services.swap-europe.com/contact>**

You must create a "ticket" via the web platform.

- Register or create your account.
- Indicate the reference of the tool.
- Choose the subject of your request.
- Describe your problem.
- Attach these files: invoice or sales receipt, photo of the identification plate (serial number), photo of the part you need (for example: pins on the transformer plug which are broken).



PRODUCT FAILURE

WHAT TO DO IF MY MACHINE BREAKS DOWN?

If you bought your product in a store:

- a) Empty the fuel tank.
- b) Make sure that your machine is complete with all accessories supplied, and clean! If this is not the case, the repairer will refuse the machine.

Go to the store with the complete machine and with the receipt or invoice.

If you bought your product on a website:

- a) Empty the fuel tank.
- b) Make sure that your machine is complete with all accessories supplied, and clean! If this is not the case, the repairer will refuse the machine.
- c) Create a SWAP-Europe service ticket on the site: <https://services.swap-europe.com> When making the request on SWAP-Europe, you must attach the invoice and the photo of the nameplate (serial number).
- d) Contact the repair station to make sure it is available before dropping off the machine.

Go to the repair station with the complete machine packed, accompanied by the purchase invoice and the station support sheet downloadable after the service request is completed on the SWAP-Europe site

For machines with engine failure from manufacturers BRIGGS & STRATTON, HONDA and RATO, please refer to the following instructions.

Repairs will be done by approved engine manufacturers of these manufacturers, see their site:

- <http://www.briggsandstratton.com/eu/fr>
- <http://www.honda-engines-eu.com/fr/service-network-page;jsessionid=5EE8456CF39CD572AA2AEEDFD290CDAE>
- <https://www.rato-europe.com/it/service-network>

Please keep your original packaging to allow for after-sales service returns or pack your machine with a similar cardboard box of the same dimensions.

For any question concerning our after-sales service you can make a request on our website <https://services.swap-europe.com>

Our hotline remains available at +33 (9) 70 75 30 30.



WARRANTY EXCLUSIONS

THE WARRANTY DOES NOT COVER:

- Start-up and setting up of the product.
- Damage resulting from normal wear and tear of the product.
- Damage resulting from improper use of the product.
- Damage resulting from assembly or start-up not in accordance with the user manual.
- Breakdowns related to carburetion beyond 90 days and fouling of carburetors.
- Periodic and standard maintenance events.
- Actions of modification and dismantling that directly void the warranty.
- Products whose original authentication marking (brand, serial number) has been degraded, altered or withdrawn.
- Replacement of consumables.
- The use of non-original parts.
- Breakage of parts following impacts or projections.
- Accessories breakdowns.
- Defects and their consequences linked to any external cause.
- Loss of components and loss due to insufficient screwing.
- Cutting components and any damage related to the loosening of parts.
- Overload or overheating.
- Poor power supply quality: faulty voltage, voltage error, etc.
- Damages resulting from the deprivation of enjoyment of the product during the time necessary for repairs and more generally the costs related to the immobilization of the product.
- The costs of a second opinion established by a third party following an estimate by a SWAP-Europe repair station
- The use of a product which would show a defect or a breakage which was not the subject of an immediate report and/or repair with the services of SWAP-Europe.
- Deterioration linked to transport and storage*.
- Launchers beyond 90 days.
- Oil, petrol, grease.
- Damages related to the use of non-compliant fuels or lubricants.

* In accordance with transport legislation, damage related to transport must be declared to carriers within 48 hours maximum after observation by registered letter with acknowledgement of receipt.

This document is a supplement to your notice, a non-exhaustive list.

Attention: all orders must be checked in the presence of the delivery person. In case of refusal by the delivery person, it you must simply refuse the delivery and notify your refusal.

Reminder: the reserves do not exclude the notification by registered letter with acknowledgement within 72 hours.

Information:

Thermal devices must be wintered each season (service available on the SWAP-Europe site). Batteries must be charged before being stored.