

FEIDER
MACHINES



JACKHAMMER

FMP1522

INSTRUCTION MANUAL

CAUTION Read the instructions before using the machine !

CONTENTS

1. SAFETY INSTRUCTIONS	3
2. PRODUCT DESCRIPTION	5
3. OPERATION	6
4. MAINTENANCE AND STORAGE	7
5. DISPOSAL	7
6. DECLARATION OF CONFORMITY	8
7. WARRANTY	9
8. PRODUCT FAILURE	10
9. WARRANTY EXCLUSIONS	11

1. SAFETY INSTRUCTIONS

1.1 GENERAL POWER TOOL SAFETY WARNINGS

⚠ WARNING Read all safety warnings, instructions, illustrations and specifications provided with this power tool. *Failure to follow all instructions listed below may result in electric shock, fire and/or serious injury.*

Save all warnings and instructions for future reference.

The term "power tool" in the warnings refers to your mains-operated (corded) power tool or battery-operated (cordless) power tool.

1) Work area safety

- a) **Keep work area clean and well lit.** *Cluttered or dark areas invite accidents.*
- b) **Do not operate power tools in explosive atmospheres, such as in the presence of flammable liquids, gases or dust.** *Power tools create sparks which may ignite the dust or fumes.*
- c) **Keep children and bystanders away while operating a power tool.** *Distractions can cause you to lose control.*

2) Electrical safety

- a) **Power tool plugs must match the outlet. Never modify the plug in any way. Do not use any adapter plugs with earthed (grounded) power tools.** *Unmodified plugs and matching outlets will reduce risk of electric shock.*
- b) **Avoid body contact with earthed or grounded surfaces, such as pipes, radiators, ranges and refrigerators.** *There is an increased risk of electric shock if your body is earthed or grounded.*
- c) **Do not expose power tools to rain or wet conditions.** *Water entering a power tool will increase the risk of electric shock.*
- d) **Do not abuse the cord. Never use the cord for carrying, pulling or unplugging the power tool. Keep cord away from heat, oil, sharp edges or moving parts.** *Damaged or entangled cords increase the risk of electric shock.*
- e) **When operating a power tool outdoors, use an extension cord suitable for outdoor use.** *Use of a cord suitable for outdoor use reduces the risk of electric shock.*
- f) **If operating a power tool in a damp location is unavoidable, use a residual current device (RCD) protected supply.** *Use of an RCD reduces the risk of electric shock.*

3) Personal safety

- a) **Stay alert, watch what you are doing and use common sense when operating a power tool. Do not use a power tool while you are tired or under the influence of drugs, alcohol or medication.** *A moment of inattention while operating power tools may result in serious personal injury.*
- b) **Use personal protective equipment. Always wear eye protection.** *Protective equipment such as a dust mask, non-skid safety shoes, hard hat or hearing protection used for appropriate conditions will reduce personal injuries.*
- c) **Prevent unintentional starting. Ensure the switch is in the off-position before connecting to power source and/or battery pack, picking up or carrying the tool.** *Carrying power tools with your finger on the switch or energising power tools that have the switch on invites accidents.*
- d) **Remove any adjusting key or wrench before turning the power tool on.** *A wrench or a key left attached to a rotating part of the power tool may result in personal injury.*
- e) **Do not overreach. Keep proper footing and balance at all times.** *This enables better control of the power tool in unexpected situations.*
- f) **Dress properly. Do not wear loose clothing or jewellery. Keep your hair and clothing away from moving parts.** *Loose clothes, jewellery or long hair can be caught in moving parts.*
- g) **If devices are provided for the connection of dust extraction and collection facilities, ensure these are connected and properly used.** *Use of dust collection can reduce dust-related hazards.*
- h) **Do not let familiarity gained from frequent use of tools allow you to become complacent and ignore tool safety principles.** *A careless action can cause severe injury within a fraction of a second.*

4) Power tool use and care

- a) **Do not force the power tool. Use the correct power tool for your application.** *The correct power tool will do the job better and safer at the rate for which it was designed.*
- b) **Do not use the power tool if the switch does not turn it on and off.** *Any power tool that cannot be controlled with the switch is dangerous and must be repaired.*
- c) **Disconnect the plug from the power source and/or remove the battery pack, if detachable, from the power tool before making any adjustments, changing accessories, or storing power tools.** *Such preventive safety measures reduce the risk of starting the power tool accidentally.*
- d) **Store idle power tools out of the reach of children and do not allow persons unfamiliar with the**

power tool or these instructions to operate the power tool. *Power tools are dangerous in the hands of untrained users.*

e) Maintain power tools and accessories. Check for misalignment or binding of moving parts, breakage of parts and any other condition that may affect the power tool's operation. If damaged, have the power tool repaired before use. *Many accidents are caused by poorly maintained power tools.*

f) Keep cutting tools sharp and clean. *Properly maintained cutting tools with sharp cutting edges are less likely to bind and are easier to control.*

g) Use the power tool, accessories and tool bits etc. in accordance with these instructions, taking into account the working conditions and the work to be performed. *Use of the power tool for operations different from those intended could result in a hazardous situation.*

h) Keep handles and grasping surfaces dry, clean and free from oil and grease. *Slippery handles and grasping surfaces do not allow for safe handling and control of the tool in unexpected situations.*

5) Service

a) Have your power tool serviced by a qualified repair person using only identical replacement parts. *This will ensure that the safety of the power tool is maintained.*

1.2 DRILL SAFETY WARNINGS

Safety instructions for all operations

a) **Wear ear protectors.** *Exposure to noise can cause hearing loss.*

b) **Use auxiliary handle(s), if supplied with the tool.** *Loss of control can cause personal injury.*

d) **Hold the power tool by insulated gripping surfaces, when performing an operation where the cutting accessory may contact hidden wiring or its own cord.** *Cutting accessory contacting a "live" wire may make exposed metal parts of the power tool "live" and could give the operator an electric shock.*

- Wear protective goggles.
- When working sparks or flying splinters, shavings, and dust can cause loss of vision.
- Working safely with this machine possible only when the operating and safety information are read completely and the instructions contained therein are strictly followed.
- Before using for the first time, ask for a practical demonstration.
- If the cable is damaged or cut through while working, do not touch the cable but immediately pull the mains plug.
- Never use the machine with a damaged cable.
- Wear safety glasses, protective gloves and sturdy shoes.
- Wear ear protection to prevent damage to your hearing.
- The machine must not be damp and must not be operated in a wet environment.
- Keep long hair away from the machine.
- Do not operate while wearing loose clothing.
- Connect the mains plug only when the tool is switched off. After using, pull the mains plug.
- Always direct the cable to the rear away from the machine.
- Do not carry the machine by the cable.
- When working with the machine, always hold it firmly with both hands and provide for a secure stance.
- During pauses in the work, when not in use or during work on the machine itself (e.g., changing of the working tools, repairs, cleaning, adjustment), pull the mains plug.
- Persons under 16 year of age are not permitted to operate this machine.
- Keep the tool accessories out of the reach of children.
- Only use original accessories.









1.3 RESIDUAL RISKS

Even when the power tool is used as prescribed it is not possible to eliminate all residual risk factors. The following hazards may arise in connection with the power tool's construction and design

- 1) Damage to lungs if an effective dust mask is not worn.
- 2) Damage to hearing if effective hearing protection is not worn.
- 3) Damages to health resulting from vibration emission if the power tool is being used over longer period of time or not adequately managed and properly maintained.

⚠️ WARNING! This power tool produces an electromagnetic field during operation. This field may under some circumstances interfere with active or passive medical implants. To reduce the risk of serious or fatal injury, we recommend persons with medical implants to consult their physician and the medical implant manufacturer before operating this machine.

1.4 SYMBOLS

	Wear hearing protection while operating the power tool.
	Wear safety glasses
	Wear a dust mask
	Wear gloves
	“Warning – To reduce the risk of injury, user must read instruction manual”
	In accordance with essential applicable safety standards of European directives
	Protection class II / double insulation
	Do not dispose of old appliances with domestic rubbish
	Guarantee sound power level

2. PRODUCT DESCRIPTION

2.1 INTENDED USE

This product is intended for use in demolition work and to break through concrete, stone or masonry. Other forms of use or changes to the product are deemed to be contrary to the intended use and may result in risks such as the danger of death, injuries and damage. The manufacturer assumes no liability for damages due to improper use. The product is not intended for commercial use or for any other use.

2.2 ABOUT YOUR TOOL

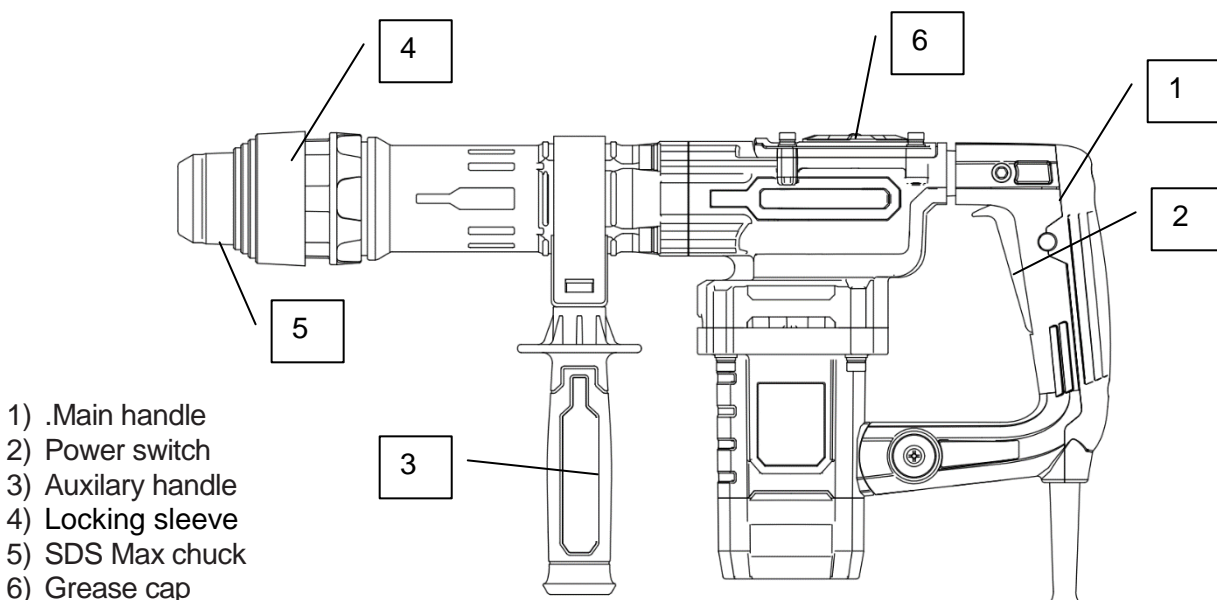

2.3 TECHNICAL DATA

Model	FMP1522
Rated voltage /frequency	220-240V~ 50HZ
Rated power (W)	1500W
Impact frequency :	3700 bpm
Class protection	Protection class II / double insulation
Sound pressure level	$L_{PA} = 90$ dB(A) ; Uncertainty K=3 dB(A)
Sound power level	$L_{WA} = 105$ dB(A); Uncertainty K=3 dB(A)
Vibration emission value	Main handle : $a_{h,CHeq} = 18,53$ m/s ² Uncertainty K=1.5 m/s ² Auxiliary handle: $a_{h,CHeq} = 14,70$ m/s ² Uncertainty K=1.5 m/s ²

Information:

- that the declared vibration total value(s) and the declared noise emission value(s) have been measured in accordance with a standard test method and may be used for comparing one tool with another;
- the declared vibration total value(s) and the declared noise emission value(s) may also be used in a preliminary assessment of exposure.

Warning:

- The vibration and noise emissions during actual use of the power tool can differ from the declared values depending on the ways in which the tool is used especially what kind of workpiece is processed;
- Need to identify safety measures to protect the operator that are based on an estimation of exposure in the actual conditions of use (taking account of all parts of the operating cycle such as the times when the tool is switched off and when it is running idle in addition to the trigger time).
- Wear hearing protection.

2.4 SCOPE OF DELIVERY

- 1x demolition hammer
- 1x additional handle (pre-assembled)
- 1x flat chisel
- 1x pointed chisel
- 1x carrying case
- 1x wrench
- A pair of carbon brush
- Flask for oil
- My-swap leaflet
- Instructions manual

3. OPERATIONS

3.1 INSTALLATION

Auxiliary handle

Loose the auxiliary handle an anti-clockwise way to adjust the side handle.

Swing the Auxiliary handle (3) around the product axis or 180 ° forward or backward into the desired position

Retighten the handle an clockwise way.

Note: only use the tool with the auxiliary handle (3)

3.2 FITTING A TOOL

Pull the locking sleeve (4) back.

Insert the tool by twisting it into the chuck system 5 until it clicks into place.

Release the locking sleeve (4) to lock the holder. Pull the tool to ensure that it is firmly locked in place. The tool has a radial clearance which is determined by the system.

3.3 REMOVING A TOOL

Pull the tool's locking sleeve (4) back and pull the tool out from the SDS max chuck system (5) .

3.4 ADJUSTING THE CHISEL POSITION

Insert the point or flat chisel into the tool SDS Max system (5) . Bring the flat chisel into the best possible working position.

3.5 SWITCHING ON AND OFF

When operating the device you can choose between intermittent or continuous operation mode.

Intermittent operation mode:

To switch on intermittent operation mode, hold the ON / OFF switch (2).

To switch off intermittent operation mode, release the ON / OFF switch (2)

Continuous operation mode:

To switch on continuous operation mode, press the ON / OFF switch (2) and lock this while pressed using the lock .

To switch off continuous operation mode, press the ON / OFF switch 2 and release it once more.

You can use the chisel on concrete, brick, stone and asphalt as well as to remove tiles and flooring.

4. MAINTENANCE AND STORAGE

Maintain your tool regularly. This will keep your tool in good working order and extend its lifespan.

Do not use abrasive, caustic agents to clean the tool. These types of products will damage your tool.

Do not perform repairs by yourself. Repairs and inspection must be carried out by a competent person or at an authorized service center (please contact you service dealer).

if the replacement of the supply cord is necessary, this has to be done by the manufacturer or his agent in order to avoid a safety hazard.

4.1 AFTER EACH USE

Check the blade, cable and body of the tool (cleanliness, wear, damage, etc.). If you notice damage, wear, or malfunction, do not use the tool and bring it to a qualified service for inspection and reparation.

There is no specific maintenance to

be performed by the user. After each season, please bring the tool to an authorized service center to perform a general cleaning and the following operations:

- Lubrication of the blade
- Mechanical check of motor, spindle, bearings and housing.
- Electrical check.
- Electrical and mechanical performance.

4.2 SPARE PARTS

You can order the spare parts directly from our Service Center. Please place your order according to the type of the machine and the parts number given in the explosion drawing.

4.3 STORAGE

After use and cleaning, please store your tool.

Store the tool in a clean, dry place, preferably in its box.

During transport and storing always put the protection cover on the blade.

The tool must be stored away from children and pets.

Avoid exposing the tool to direct sunlight.

5. DISPOSAL



Electric power tools, as well as their accessories and packaging, must each be able to follow an appropriate recycling pathway. Only for the countries of the European Union.

Do not throw away your electrical appliance with the household waste! In accordance with the European Directive 2012/19/EU on waste electrical and electronic equipment and its implementation in national laws, power tools that can no longer be used must be separated and follow an

appropriate recycling pathway.

6. DECLARATION OF CONFORMITY



Declaration of conformity

BUILDER SAS

ZI, 32 RUE ARISTIDE BERGES – 312070 CUGNAUX – FRANCE

Declares that the machinery designated below:

JACK HAMMER

Model: FMP1522

Serial number: 20220609498-20220611497

Complies with the provisions of the Directive « machinery » 2006/42/EC and national laws transposing it:

Also complies with the following European directives:

EMC Directive 2014/30/EU

ROHS Directive (EU)2015/863 amending 2011/65/EU

Noise directive 2000/14/EC+ANNEX VI & 2005/88/EC

Guarantee sound power level: 105 dB(A)

Also complies with European standards, with national standards and the following technical provisions:

EN 62841-1:2015

EN IEC 62841-2-6:2020+A11:2020

EN IEC 55014-1:2021

EN IEC 55014-2:2021

EN IEC 61000-3-2:2019+A1: 2021

EN 61000-3-3:2013+A1: 2019

The technical documentation is kept by: Olivier Patriarca

Cugnaux, 22/03/2022

Philippe MARIE / PDG

7. WARRANTY

The manufacturer guarantees the product against defects in material and workmanship for a period of 2 years from the date of the original purchase. The warranty only applies if the product is for household use. The warranty does not cover breakdowns due to normal wear and tear.

The manufacturer agrees to replace parts identified as defective by the designated distributor. The manufacturer does not accept responsibility for the replacement of the machine, in whole or in part, and/or ensuing damage.

The warranty does not cover breakdowns due to:

- insufficient maintenance.
- abnormal assembly, adjustment or operations of the product.
- parts subject to normal wear and tear.

The warranty does not extend to:

- shipping and packaging costs.
- using the tool for a purpose other than that for which it was designed.
- the use and maintenance of the machine done in a manner not described in the user manual.

Due to our policy of continuous product improvement, we reserve the right to alter or change specifications without notice. Consequently, the product may be different from the information contained therein, but a modification will be undertaken without notice if it is recognized as an improvement of the preceding characteristic.

READ THE MANUAL CAREFULLY BEFORE USING THE MACHINE.

When ordering spare parts, please indicate the part number or code, you can find this in the spare parts list in this manual. Keep the purchase receipt; without it, the warranty is invalid. To help you with your product, we invite you to contact us by phone or via our website:

+33 (0)9.70.75.30.30

<https://services.swap-europe.com/contact>

You must create a "ticket" via the web platform.

- Register or create your account.
- Indicate the reference of the tool.
- Choose the subject of your request.
- Describe your problem.

Attach these files: invoice or sales receipt, photo of the identification plate (serial number), photo of the part you need (for example: pins on the transformer plug which are broken).



8. PRODUCT FAILURE

WHAT TO DO IF MY MACHINE BREAKS DOWN?

If you bought your product in a store:

- Make sure that your machine is complete with all accessories supplied, and clean! If this is not the case, the repairer will refuse the machine.
- Go to the store with the complete machine and with the receipt or invoice.

If you bought your product on a website:

- Make sure that your machine is complete with all accessories supplied, and clean! If this is not the case, the repairer will refuse the machine.
- Create a SWAP-Europe service ticket on the site: <https://services.swap-europe.com> When making the request on SWAP-Europe, you must attach the invoice and the photo of the nameplate (serial number).

Contact the repair station to make sure it is available before dropping off the machine.

Go to the repair station with the complete machine packed, accompanied by the purchase invoice and the station support sheet downloadable after the service request is completed on the SWAP-Europe site

Please keep your original packaging to allow for after-sales service returns or pack your machine with a similar cardboard box of the same dimensions.

For any question concerning our after-sales service you can make a request on our website <https://services.swap-europe.com>

Our hotline remains available at +33 (9) 70 75 30 30.



9. WARRANTY EXCLUSIONS

THE WARRANTY DOES NOT COVER:

- Start-up and setting up of the product.
- Damage resulting from normal wear and tear of the product.
- Damage resulting from improper use of the product.
- Damage resulting from assembly or start-up not in accordance with the user manual.
- Breakdowns related to carburetion beyond 90 days and fouling of carburetors.
- Periodic and standard maintenance events.
- Actions of modification and dismantling that directly void the warranty.
- Products whose original authentication marking (brand, serial number) has been degraded, altered or withdrawn.
- Replacement of consumables.
- The use of non-original parts.
- Breakage of parts following impacts or projections.
- Accessories breakdowns.
- Defects and their consequences linked to any external cause.
- Loss of components and loss due to insufficient screwing.
- Cutting components and any damage related to the loosening of parts.
- Overload or overheating.
- Poor power supply quality: faulty voltage, voltage error, etc.
- Damages resulting from the deprivation of enjoyment of the product during the time necessary for repairs and more generally the costs related to the immobilization of the product.
- The costs of a second opinion established by a third party following an estimate by a SWAP-Europe repair station
- The use of a product which would show a defect or a breakage which was not the subject of an immediate report and/or repair with the services of SWAP-Europe.
- Deterioration linked to transport and storage*.
- Launchers beyond 90 days.
- Oil, petrol, grease.
- Damages related to the use of non-compliant fuels or lubricants.

* In accordance with transport legislation, damage related to transport must be declared to carriers within 48 hours maximum after observation by registered letter with acknowledgement of receipt. This document is a supplement to your notice, a non-exhaustive list.

Attention: all orders must be checked in the presence of the delivery person. In case of refusal by the delivery person, it you must simply refuse the delivery and notify your refusal.

Reminder: the reserves do not exclude the notification by registered letter with acknowledgement within 72 hours.

Information:

Thermal devices must be wintered each season (service available on the SWAP-Europe site). Batteries must be charged before being stored.



BUILDER SAS
32, rue Aristide Bergès - ZI 31270 Cugnaux – France
Made in PRC 2022