

FEIDER

MACHINES

INSTRUCTION MANUAL

ELECTRIC MIXER

Model :FM1800



BUILDER SAS
32, rue Aristide Bergès - ZI 31270 Cugnaux – France
MADE IN PRC:2021

Warning: To reduce the risk of injury, please read instruction manual before use.

CONTENT

1. INTRODUCTION.....	3
2. SAFETY WARNINGS.....	3
3. PROPER USE.....	5
4. THE PRODUCT.....	5
5. BEFORE FIRST USE.....	7
6. OPERATION.....	7
7. MAINTENANCE CLEANING AND STORAGE.....	7
8. DISPOSAL.....	8
9. EC DECLARATION OF CONFORMITY.....	9
10. WARRANTY.....	10
11. PRODUCT FAILURE.....	11
12. WARRANTY EXCLUSIONS.....	12

1. INTRODUCTION

Please make sure you familiarize yourself fully with the way the device works before you use it for the first time and that you understand how to handle electrical power tools correctly. To help you do this please read the accompanying operating instructions. Keep these instructions in a safe place. If you pass the device on to anyone else, please ensure that you also pass on all the documentation.

2. SAFETY INSTRUCTIONS

GENERAL POWER TOOL SAFETY WARNINGS



WARNING Read all safety warnings, instructions, illustrations and specifications provided with this power tool. *Failure to follow all instructions listed below may result in electric shock, fire and/or serious injury.*

Save all warnings and instructions for future reference.

The term "power tool" in the warnings refers to your mains-operated (corded) power tool or battery-operated (cordless) power tool.

1) Work area safety

- a) **Keep work area clean and well lit.** *Cluttered or dark areas invite accidents.*
- b) **Do not operate power tools in explosive atmospheres, such as in the presence of flammable liquids, gases or dust.** *Power tools create sparks which may ignite the dust or fumes.*
- c) **Keep children and bystanders away while operating a power tool.** *Distractions can cause you to lose control.*

2) Electrical safety

- a) **Power tool plugs must match the outlet. Never modify the plug in any way. Do not use any adapter plugs with earthed (grounded) power tools.** *Unmodified plugs and matching outlets will reduce risk of electric shock.*
- b) **Avoid body contact with earthed or grounded surfaces, such as pipes, radiators, ranges and refrigerators.** *There is an increased risk of electric shock if your body is earthed or grounded.*
- c) **Do not expose power tools to rain or wet conditions.** *Water entering a power tool will increase the risk of electric shock.*
- d) **Do not abuse the cord. Never use the cord for carrying, pulling or unplugging the power tool. Keep cord away from heat, oil, sharp edges or moving parts.** *Damaged or entangled cords increase the risk of electric shock.*
- e) **When operating a power tool outdoors, use an extension cord suitable for outdoor use.** *Use of a cord suitable for outdoor use reduces the risk of electric shock.*
- f) **If operating a power tool in a damp location is unavoidable, use a residual current device (RCD) protected supply.** *Use of an RCD reduces the risk of electric shock.*

3) Personal safety

- a) **Stay alert, watch what you are doing and use common sense when operating a power tool. Do not use a power tool while you are tired or under the influence of drugs, alcohol or medication.** *A moment of inattention while operating power tools may result in serious personal injury.*
- b) **Use personal protective equipment. Always wear eye protection.** *Protective equipment such as a dust mask, non-skid safety shoes, hard hat or hearing protection used for appropriate conditions will reduce personal injuries.*
- c) **Prevent unintentional starting. Ensure the switch is in the off-position before connecting to power source and/or battery pack, picking up or carrying the tool.** *Carrying power tools with your finger on the switch or energising power tools that have the switch on invites accidents.*

- d) **Remove any adjusting key or wrench before turning the power tool on.** *A wrench or a key left attached to a rotating part of the power tool may result in personal injury.*
- e) **Do not overreach. Keep proper footing and balance at all times.** *This enables better control of the power tool in unexpected situations.*
- f) **Dress properly. Do not wear loose clothing or jewellery. Keep your hair and clothing away from moving parts.** *Loose clothes, jewellery or long hair can be caught in moving parts.*
- g) **If devices are provided for the connection of dust extraction and collection facilities, ensure these are connected and properly used.** *Use of dust collection can reduce dust-related hazards.*
- h) **Do not let familiarity gained from frequent use of tools allow you to become complacent and ignore tool safety principles.** *A careless action can cause severe injury within a fraction of a second.*

4) Power tool use and care

- a) **Do not force the power tool. Use the correct power tool for your application.** *The correct power tool will do the job better and safer at the rate for which it was designed.*
- b) **Do not use the power tool if the switch does not turn it on and off.** *Any power tool that cannot be controlled with the switch is dangerous and must be repaired.*
- c) **Disconnect the plug from the power source and/or remove the battery pack, if detachable, from the power tool before making any adjustments, changing accessories, or storing power tools.** *Such preventive safety measures reduce the risk of starting the power tool accidentally.*
- d) **Store idle power tools out of the reach of children and do not allow persons unfamiliar with the power tool or these instructions to operate the power tool.**
Power tools are dangerous in the hands of untrained users.
- e) **Maintain power tools and accessories. Check for misalignment or binding of moving parts, breakage of parts and any other condition that may affect the power tool's operation. If damaged, have the power tool repaired before use.** *Many accidents are caused by poorly maintained power tools.*
- f) **Keep cutting tools sharp and clean.** *Properly maintained cutting tools with sharp cutting edges are less likely to bind and are easier to control.*
- g) **Use the power tool, accessories and tool bits etc. in accordance with these instructions, taking into account the working conditions and the work to be performed.** *Use of the power tool for operations different from those intended could result in a hazardous situation.*
- h) **Keep handles and grasping surfaces dry, clean and free from oil and grease.** *Slippery handles and grasping surfaces do not allow for safe handling and control of the tool in unexpected situations.*

5) Service

- a) **Have your power tool serviced by a qualified repair person using only identical replacement parts.** *This will ensure that the safety of the power tool is maintained.*

Mixer safety instructions

- a) **Hold the tool with both hands at the intended handles.** *Loss of control can cause personal injury.*
- b) **Ensure sufficient ventilation when mixing flammable materials to avoid a hazardous atmosphere.** *Developing vapour may be inhaled or be ignited by the sparks the power tool produces.*
- c) **Do not mix food.** *Power tools and their accessories are not designed for processing food.*
- d) **Keep the cord away from the working area.** *The cord may be entangled by the mixer basket.*
- e) **Ensure that the mixing container is placed in a firm and secure position.** *A container that is not properly secured may move unexpectedly.*
- f) **Ensure that no liquid splashes against the housing of the power tool.** *Liquid that has penetrated the power tool can cause damage and lead to electric shock.*
- g) **Follow the instructions and warnings for the material to be mixed.** *Material to be mixed may be harmful.*
- h) **If the power tool falls into the material to be mixed, unplug the tool immediately and have the power tool checked by a qualified repair person.** *Reaching into the bucket with the tool still plugged in can lead to electric shock.*
- i) **Do not reach into the mixing container with your hands or insert any other objects into it while mixing.** *Contact with the mixer basket may lead to serious personal injury.*

j) **Start up and run down the tool in the mixing container only.** *The mixer basket may bend or spin in an uncontrolled manner.*

The following pictograms may be used in these operating instructions / on the device:



WARNING—To reduce the risk of injury, user must read instruction manual



Do not work with material containing asbestos, wear a dust mask



Wear eye protection



Wear hearing protection

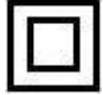

Class II appliance



Dispose packaging and appliance in an environmentally-friendly way!

3. PROPER USE

The machine is only intended for mixing concrete, cement or paint. Improper use may damage the tool. Any other use or modification to the device shall be considered as improper use and could give rise to considerable risk of accident. The manufacturer will not accept liability for loss or damage arising from improper use. The device is not intended for commercial use.

4. THE PRODUCT

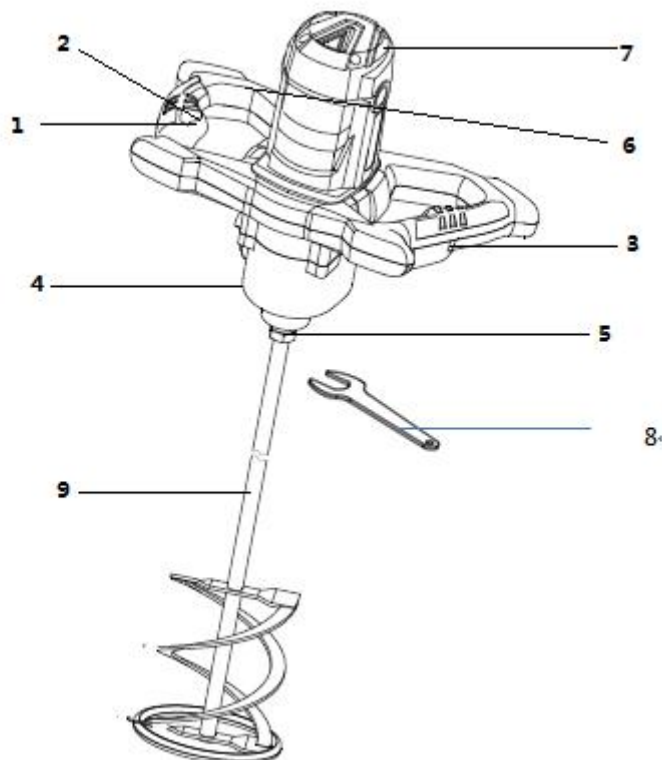

1. ON / OFF switch
2. Switch lock
3. Speed control wheel
4. Speed selector switch
5. Tool mount

6. Supplementary handle
7. Ventilation apertures
8. Wrench
9. Whisk

Included items

- 2 wrenches
- 1 Operating instruction

Technical data

Nom. Voltage:	230 -240V ~ 50 Hz
Rated Power:	1800W
No-load speed:	I: 180-400/min,II:300-700/min
Spindle size	M14
Whisk	ø 160 mm
Weight	4.45 kg
Protection class:	II / 
Degree of protection	IPX0

Noise and vibration data:

Values determined in accordance with EN 62841

The sound pressure level (L_{pA}) of the device is typically 87, 6 dB (A). Uncertainty K = 3 dB

The sound power level (L_{wA}) of the device is typically 98, 6 dB (A). Uncertainty K = 3 dB



Wear ear protection!

Max. Vibration emission value is 5,187 m/s^2 ; Uncertainty K = 1,5 m/s^2

Information:

- The declared vibration total value has been measured in accordance with a standard test method and may be used for comparing one tool with another;
- The declared vibration total value may also be used in a preliminary assessment of exposure.

Warning:

- The vibration emission during actual use of the power tool can differ from the declared total value depending on the ways in which the tool is used;
- need to identify safety measures to protect the operator that are based on an estimation of exposure in the actual conditions of use (taking account of all parts of the operating cycle such as the times when the tool is switched off and when it is running idle in addition to the trigger time).

Caution utility services!

DANGER! Ensure that you do not strike electrical cables, gas or water pipes when you are working with the electrical power tool. Check a wall using a suitable detector before you drill or cut slots.

Original accessories / attachments

Use only the accessories and attachments detailed in the operating instructions.

The use of inserted tools or accessories other than those recommended in the operating instructions could lead to you suffering an injury.

5. BEFORE FIRST USE

WARNING! DANGER OF INJURY! Switch the device off and pull the plug out of the mains socket before carrying out any work in the device.

Placing a whisk

NOTE: Use only whisks in conformity the specified diameter.

- Screw the whisk with thread (M14) as far as possible in the tool.
- Tighten the whisk properly with an open-end wrench.

First use

The mains voltage at the mains socket must match with the data shown on the rating plate on the device.

6. OPERATION

Improper use may damage the instrument. Observe therefore these instructions:

- Use a tool up to the specified diameter.
 - Load the tool in such a way that the speed would not drop considerably or that it would stop.
- Check if the data on the rating plate correspond with the actual mains voltage.

Switching on and off

- To switch on the tool, push and hold the switch lock button. Then, press and hold the on/off switch (1). The lock switch button can be released.
- If you release the on/off switch, the tool will be switched off.

Infinitely adjustable speed setting

Two rpm ranges can be pre-selected with the speed selector switch (4):

Gear 1 180-400 /min

Gear 2 300-700 /min

The necessary speed depends on the type of the material mixed and it is recommended to verify it by a practical test.

7. MAINTENANCE CLEANING AND STORAGE

WARNING! DANGER OF INJURY!

Switch the device off and pull the plug out of the mains socket before carrying out any work on the device.

Correct maintenance for the machine can prolong the working life; the handle switch must always keep in proper function and good maintenance;

The mixing tools should be cleaned when the operation is finish or no use for long time; Use a cloth to clean the device.

Normally the flowing water or sand can clean the mixing tools well. Do not under any circumstances use petrol or strong solvents. Do not allow any liquids to enter the device.

Do not force any mechanical stress in the machine, such as pound, because it will be unavoidable damaged;

The mixing shaft must always be antipollution; the threaded hole must always be put protecting cover;

The vent of motor housing cannot be covered when the machine is in operation, there cannot be any flammable materials in the machine; the vent must be often cleaned;

Store the device & accessories in a dry room where out of the reach of children also.

Only original parts can be used in this machine.

The carbon brush must be checked and maintenance when the machine operation up to 60hours, please change the brush in time if find the brush worn out.

Loosen carbon brush cap first, Pull out and replace the carbon brush (Always replace the two brushes at the same time), screw carbon brush caps.

Service centre

WARNING! Have your device repaired only by qualified specialist personnel using original manufacturer parts only. This will ensure that your device remains safe to use.

WARNING! If the supply cord of this power tool is damaged, it must be replaced by a specially prepared supply cord available through the service organization.

8. DISPOSAL

The packaging is wholly composed of environmentally-friendly materials that can be disposed of at a local recycling centre.



■ Electrical products should not be discarded with household products. According to the European Directive 2012/19/EU on waste electrical and electronic equipment and its implementation into national law, electrical products used must be collected separately and disposed of at collection points provided for this purpose. Talk with your local authorities or dealer for advice on recycling.

9. EC DECLARATION OF CONFORMITY



EC Declaration of conformity

BUILDER SAS

32, rue Aristide Bergès - ZI 31270 Cugnaux – France declare that the machine

Designation: ELECTRIC MIXER

Model: FM1800

Serial number: 20210523981-20210525180

Is in conformity with the European Directives:

Machine Directive 2006/42/EC

EMC Directive 2014/35/EU

RoHS Directive 2011/65/UE+(EU) 2015/863

This product is also in conformity with the following standards:

EN 62841-1: 2015

EN 62841-2-10: 2017

EN 55014-1: 2017

EN 55014-2: 2015

EN61000-3-2: 2014

EN61000-3-2: 2019

EN 61000-3-3: 2013

EN 61000-3-3: 2013 +A11:2019

Philippe MARIE / PDG

Cugnaux, le 21/01/2020

Responsible of technical file: M Olivier Patriarca

10. WARRANTY



WARRANTY

The manufacturer guarantees the product against defects in material and workmanship for a period of 2 years from the date of the original purchase. The warranty only applies if the product is for household use. The warranty does not cover breakdowns due to normal wear and tear.

The manufacturer agrees to replace parts identified as defective by the designated distributor. The manufacturer does not accept responsibility for the replacement of the machine, in whole or in part, and/or ensuing damage.

The warranty does not cover breakdowns due to:

- insufficient maintenance.
- abnormal assembly, adjustment or operations of the product.
- parts subject to normal wear and tear.

The warranty does not extend to:

- shipping and packaging costs.
- using the tool for a purpose other than that for which it was designed.
- the use and maintenance of the machine done in a manner not described in the user manual.

Due to our policy of continuous product improvement, we reserve the right to alter or change specifications without notice. Consequently, the product may be different from the information contained therein, but a modification will be undertaken without notice if it is recognized as an improvement of the preceding characteristic.

READ THE MANUAL CAREFULLY BEFORE USING THE MACHINE.

When ordering spare parts, please indicate the part number or code, you can find this in the spare parts list in this manual. Keep the purchase receipt; without it, the warranty is invalid. To help you with your product, we invite you to contact us by phone or via our website:

- **+33 (0)9.70.75.30.30**
- **<https://services.swap-europe.com/contact>**

You must create a "ticket" via the web platform.

- Register or create your account.
- Indicate the reference of the tool.
- Choose the subject of your request.
- Describe your problem.
- Attach these files: invoice or sales receipt, photo of the identification plate (serial number), photo of the part you need (for example: pins on the transformer plug which are broken).



11. PRODUCT FAILURE

WHAT TO DO IF MY MACHINE BREAKS DOWN?

If you bought your product in a store:

- a) Empty the fuel tank.
- b) Make sure that your machine is complete with all accessories supplied, and clean! If this is not the case, the repairer will refuse the machine.

Go to the store with the complete machine and with the receipt or invoice.

If you bought your product on a website:

- a) Empty the fuel tank.
- b) Make sure that your machine is complete with all accessories supplied, and clean! If this is not the case, the repairer will refuse the machine.
- c) Create a SWAP-Europe service ticket on the site: <https://services.swap-europe.com> When making the request on SWAP-Europe, you must attach the invoice and the photo of the nameplate (serial number).
- d) Contact the repair station to make sure it is available before dropping off the machine.

Go to the repair station with the complete machine packed, accompanied by the purchase invoice and the station support sheet downloadable after the service request is completed on the SWAP-Europe site

For machines with engine failure from manufacturers BRIGGS & STRATTON, HONDA and RATO, please refer to the following instructions.

Repairs will be done by approved engine manufacturers of these manufacturers, see their site:

- <http://www.briggsandstratton.com/eu/fr>
- <http://www.honda-engines-eu.com/fr/service-network-page;jsessionid=5EE8456CF39CD572AA2AEEDFD290CDAE>
- <https://www.rato-europe.com/it/service-network>

Please keep your original packaging to allow for after-sales service returns or pack your machine with a similar cardboard box of the same dimensions.

For any question concerning our after-sales service you can make a request on our website <https://services.swap-europe.com>

Our hotline remains available at +33 (9) 70 75 30 30.



12. WARRANTY EXCLUSIONS

THE WARRANTY DOES NOT COVER:

- Start-up and setting up of the product.
- Damage resulting from normal wear and tear of the product.
- Damage resulting from improper use of the product.
- Damage resulting from assembly or start-up not in accordance with the user manual.
- Breakdowns related to carburetion beyond 90 days and fouling of carburetors.
- Periodic and standard maintenance events.
- Actions of modification and dismantling that directly void the warranty.
- Products whose original authentication marking (brand, serial number) has been degraded, altered or withdrawn.
- Replacement of consumables.
- The use of non-original parts.
- Breakage of parts following impacts or projections.
- Accessories breakdowns.
- Defects and their consequences linked to any external cause.
- Loss of components and loss due to insufficient screwing.
- Cutting components and any damage related to the loosening of parts.
- Overload or overheating.
- Poor power supply quality: faulty voltage, voltage error, etc.
- Damages resulting from the deprivation of enjoyment of the product during the time necessary for repairs and more generally the costs related to the immobilization of the product.
- The costs of a second opinion established by a third party following an estimate by a SWAP-Europe repair station
- The use of a product which would show a defect or a breakage which was not the subject of an immediate report and/or repair with the services of SWAP-Europe.
- Deterioration linked to transport and storage*.
- Launchers beyond 90 days.
- Oil, petrol, grease.
- Damages related to the use of non-compliant fuels or lubricants.

* In accordance with transport legislation, damage related to transport must be declared to carriers within 48 hours maximum after observation by registered letter with acknowledgement of receipt.

This document is a supplement to your notice, a non-exhaustive list.

Attention: all orders must be checked in the presence of the delivery person. In case of refusal by the delivery person, it you must simply refuse the delivery and notify your refusal.

Reminder: the reserves do not exclude the notification by registered letter with acknowledgement within 72 hours.

Information:

Thermal devices must be wintered each season (service available on the SWAP-Europe site). Batteries must be charged before being stored.