

FEIDER



STEAM CLEANER

FHNVM1200

USER GUIDE

CAUTION: Read this manual before using this machine!

CONTENTS

1. SAFETY WARNINGS.....	3
2. INTENDED USE.....	5
3. YOUR PRODUCT AND ACCESSORIES.....	6
4. OPERATION.....	8
5. INSTRUCTIONS OF ACCESSORIES.....	9
6. CLEANING.....	11
7. TROUBLESHOOTING.....	11
8. STORAGE.....	12
9. DISPOSAL.....	12
10. DECLARATION OF CONFORMITY.....	12
11. WARRANTY.....	13
12. PRODUCT FAILURE.....	14
13. WARRANTY EXCLUSIONS.....	15

1. SAFETY WARNINGS

Before using this device, please read this manual carefully and keep it for future use. If you pass this device on to someone else, pass this manual as well.

- Appliances can be used by persons with reduced physical, sensory or mental capabilities or lack of experience and knowledge if they have been given supervision or instruction concerning use of the appliance in a safe way and if they understand the hazards involved. Children shall not play with the appliance.
- The appliance shall not be left unattended while it is connected to the supply mains. Keep children and pets away from the device during use.
- The filling aperture shall not be opened during use. Follow the instructions given in this manual for the safe filling of the water tank.
- The appliance is not to be used if it has been dropped, if there are visible signs of damage or if it is leaking
- Keep the appliance out of reach of children when it is energized or cooling down.
- The liquid or steam must not be directed towards equipment containing electrical components, such as the interior of ovens.



- **Caution! Danger of scalding.**
- The appliance must be unplugged after use and before maintenance by the user.
- The plug must be removed from the socket-outlet before cleaning or maintaining the device.
- If the supply cord is damaged, it must be replaced by

the manufacturer, its service agent or similarly qualified persons in order to avoid a hazard.

- CAUTION: Make sure the device is turned off before removing the accessory.
- The device must not be submerged in water.
- Refer to CLEANING AND MAINTENANCE section for cleaning and descaling instructions.
- This appliance is designed for indoor use only.
- Fill the device only with water.
- Switch off the appliance and unplug the power cable after use and before any maintenance and cleaning operations.
- Inspect the unit regularly for signs of damage. Do not use a damaged device. Do not try to repair the device yourself. The repair must only be made by the manufacturer, its after-sales service or persons of similar qualification in order to avoid a danger.
- Remove all packing materials before using the appliance. Keep packaging materials out of the reach of children, as these materials can be dangerous.
- Check that the supply voltage indicated on the nameplate corresponds to the voltage of your home.
- Do not expose the device to heat. Do not place the device near heat sources such as a stove or heater.
- Attention! Always use shoes when using the steam mop! The floor becomes hot when using the appliance.
- Do not direct steam at people, animals, electrical appliances or electrical outlets.
- Do not remove or fill the water tank while the steam mop is on.
- Please refer to the instructions in this manual for the

type and amount of fluid to use.

- Surfaces are likely to be hot during use.
- Do not put heavy weight on power cord.
- Do not touch directly the steam.
- Do not drain the appliance when it is connected to water mains.
- Do not use the appliance when there is no water in water tank. Always fill the tank before use the tool.
- Use the appliance in a ventilated room.
- Always put the children lock when the appliance is not used.
- Let the appliance cool before change, replace or remove any parts.
- Do not spray the steam to clean glass in the same position more than 2 seconds.
- Do not clean window if temperature is lower than 0°C.
- Revolve the safety valve before power on or hot water will pour out.
- During production, each appliance is tested to ensure the quality of the finished product. It is therefore possible that there is water residue inside the device.

2. INTENDED USE







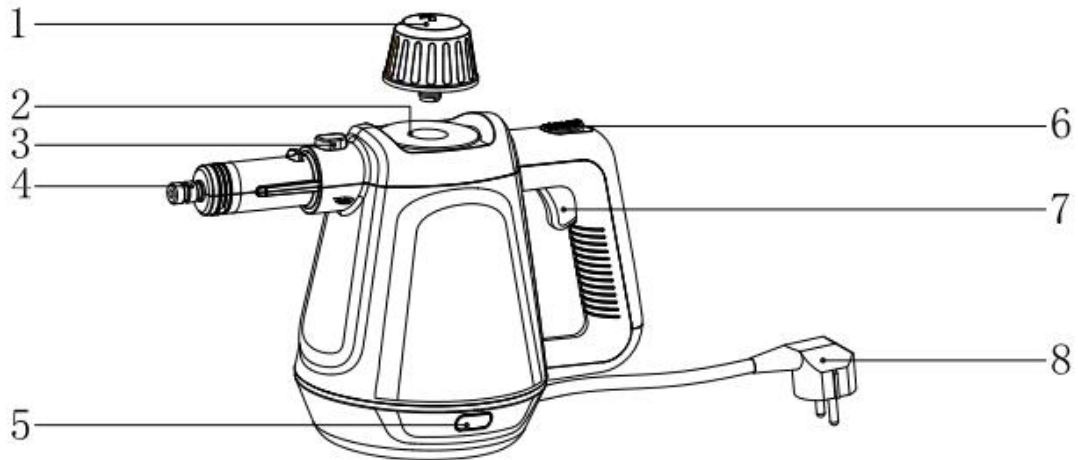

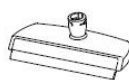

- The steam cleaner is only designed for removing dirt with water vapor. It is suitable for cleaning the following areas: smooth surfaces (e.g. work areas, tiles, glazed tiles, windows or mirrors), hard-to-reach areas (e.g. corners, grouting, blinds, WC, fittings) and textiles (e.g. curtains, cushions, articles of clothing and car seats).
- The steam cleaner is only intended for private use and is not suitable for commercial purposes. The steam cleaner is not intended for use outdoors or for use with liquids other than water.
- Only use the steam cleaner as described in this user manual. Any other use is deemed improper and may result in damage to property or even personal injury.
- The steam cleaner is not a children's toy.
- The manufacturer or vendor accepts no liability for damage caused by improper or incorrect use.

3. YOUR PRODUCT AND ACCESSORIES

Description:

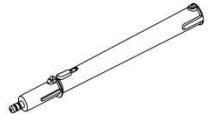

No.	Name	Function
1	Safety cap	Maintain pressure balance & Lock the filling hole
2	Filling hole	Fill water inside
3	Attachment lock	Use for fastening various accessories connection, press it to remove the accessories
4	Steam outlet	For steam output
5	Indicator light	Red means heating, green means appliance is ready
6	Trigger lock	To lock/unlock the trigger
7	steam trigger	Control steam after pressing in the working state
8	Power plug	Plug it into a socket to provide power to the machine

Funnel x1		Measuring cup x 1	
Towel set x1		Flat brush x 1	
Big nozzle x 1		Extension hose x 1	
Nylon brush x 1		Stainless brush x 1	
Floor brush x 1		Connect of floor brush x1	
Extension tube x 3		Floor brush towel x1	

Technical data:

Voltage and frequency: 220-240V~, 50-60Hz,

Power: 1200W

Degree of protection: IPX4

4. OPERATION

1. Put the steam cleaner on the platform and open the safety cap.
2. Use the measuring cup and funnel to fill the water. Maximum volume is 400ml. We suggest you only fill water 300-350ml to get the dry steam. If more than 350ml water, there may be some water in the steam at the first 2 minutes.



Special attention:

- Please use clean water (small solid particles may block pipe or make machine failure)
- Please do not pour any chemicals such as alcohol, cleaning agents into the steam cleaner. (some chemical solvents can easily cause machine failure, and even endanger the user's personal safety in serious cases).
- If the tap water in your area is very hard, it is recommended that you mix the tap water with distilled water. Otherwise, the steam cleaner could calcify prematurely and clog the steam nozzle.
- Please do not add water less than 150ml.
- Close the safety cap clockwise.
- Insert the mains plug into the socket, the red light will light up indicate heating. As soon as the steam cleaner is operational, the green indicator light will on. The red indicator light will on/off during usage.

Attention:

- Only use the product once the green indicator light On at the first time. Otherwise, hot water that drips or sprays.
- Turn the children lock to "on" position, then press the steam trigger. Steam will be released directly. Remember you should always press the steam trigger. Once you released the steam trigger, the children lock will turn back to "OFF" position auto and steam stopped.

Attention:

If there is no more water in the water tank, no more steam will be emitted when you push the steam trigger. The water must be refilled as follows:

- Pull the main plug out of the socket.
- Push the steam trigger until no more steam is escaping.
- Wait for cooling at least 12-18 minutes.
- Slowly unscrew the safety cap and wait a few seconds
- Slowly refill the water tank with water.
- Close the safety cap again.

If the tap water in your area is very hard, it is recommended that you mix the tap water with distilled water. Otherwise, the steam cleaner could calcify prematurely and clog the steam nozzle.

After usage, please turn the power off, release all the residual steam and wait for the machine cooling down.

The steam cleaner has an overheat protection. It will automatically switch off if it overheats (e.g. when the water tank is empty).

5. INSTRUCTIONS OF ACCESSORIES

1) Extension hose

If the steam cleaner is hard to reach the cleaning area, it can be used with an extension hose. The operation method is as follows: connect the end of the hose to the steam outlet until hearing a clicking sound.

To disconnect the extension hose, press the release button on the device and remove the hose.

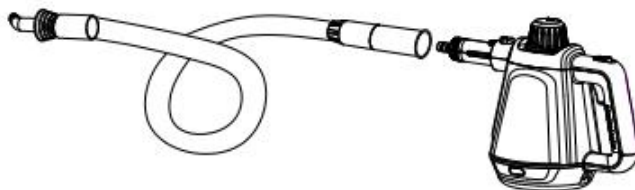

2) Big nozzle

The big nozzle can be used to clean the corners easily by connecting with steam outlet like extension hose.

To disconnect the nozzle, press the release button on the device and then remove the nozzle.

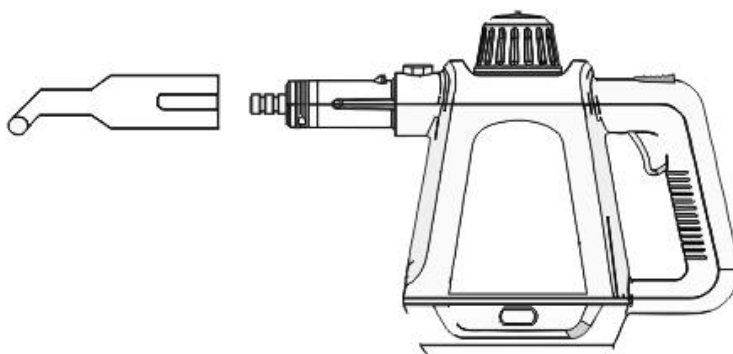

3) Flat brush

Insert the big nozzle into the notch of the flat brush (below picture 1), and turn it clockwise until it clicks.

It can clean the flat surface like window etc. After use, take out the flat brush by turn it anti-clockwise.

To disconnect the nozzle, press the release button on the device and then remove the nozzle.

For cleaning desk and chair, bookcase, or ironing clothes, put a white towel on the flat brush.

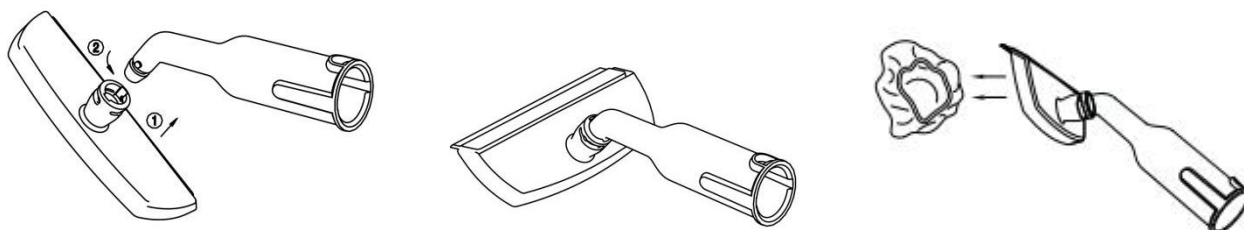

4) Nylon and stainless brush

Insert the big nozzle into the notch of the round brush (below picture 1), and turn it clockwise until it clicks.

After use, take out the round brush by turn it anti-clockwise.

To disconnect the nozzle, press the release button on the device and then remove the nozzle.



5) Extension tube

If some areas are difficult to access or if the appliance is used to clean the floor or glass surfaces, use the extension cords provided. Connect the end of the extension cord to the outlet of the appliance. You don't have to put on all three extensions at the same time.

To disconnect extension cords and accessories, press the release button to remove the extension cords and accessory.

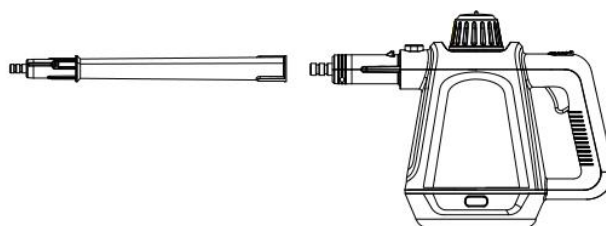

6) Floor brush (floor brush towel)

Connect the floor brush connector to the floor brush. Then connect one or more extension cords to the device. Finally, connect the floor brush to the extension cord.

To install a mop, open the clips on both sides of the floor brush and attach the mop.

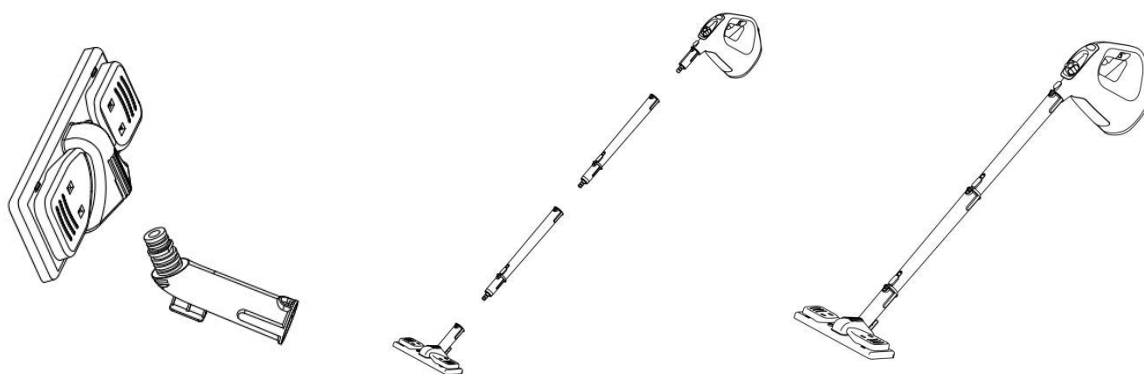

7) Steam temperature

Below data is for users' reference, we can adjust the operation method in order to reach better cleaning performance.

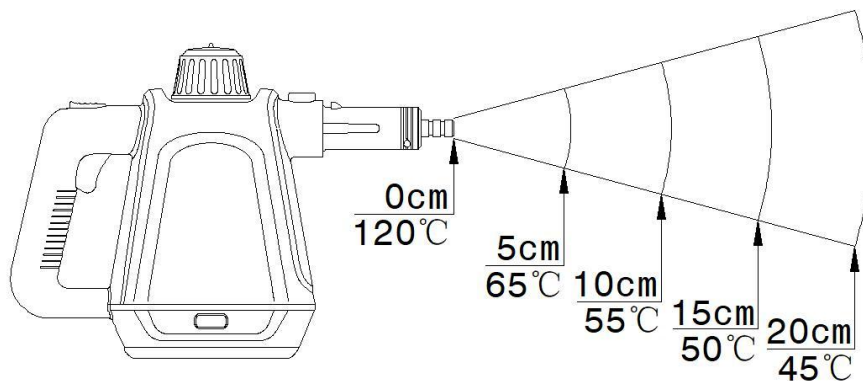

Attention: The above data are measured by the laboratory, and there will be a little deviation in practice.

6. CLEANING

- 1) Before cleaning, pull the mains plug out of the socket.
- 2) Let the steam cleaner cool off completely.
- 3) Wipe the steam cleaner and the accessories off with a damp cloth. Then let all parts dry completely.

7. TROUBLESHOOTING

Situation	Abnormal analysis	Solution
No spray steam	Plug not insert to the power socket tightly	Reinsert or change socket
	No water in the boiler	Add water
	Not press the steam button	Press on children lock
	Other problem	Ask professional service
Only green light is on, Red light is always off	Indicator light broken or short circuit of line	Ask professional service
Red light is always on, green light is off	Thermostat is broken	Ask professional service
Red light flicker	A lack of water or poor connect	The problem still exists after filling water, ask professional service
Water is flowing from the nozzle	There may some water in the steam for first usage or stopped for a while	Normal phenomenon Will disappear quickly
	Influence the normal use	Ask professional service
Others	Steam come out besides the nozzle	Ask professional service
	Plastic deformation and softening phenomenon	
	Steam come out from safety valve	

8. STORAGE

All parts must be completely dry before being stored.

- Always store the steam cleaner in a dry, clean and dust-free place.
- Store the steam cleaner under lock place so that it is not accessible for children.

9. DISPOSAL

Electrical products should not be discarded with household products. According to the European Directive 2012/19/EU on waste electrical and electronic equipment and its implementation into national law, electrical products used must be collected separately and disposed of at collection points provided for this purpose. Talk with your local authorities or dealer for advice on recycling.



10. DECLARATION OF CONFORMITY



BUILDER SAS

32, rue Aristide Bergès - ZI 31270 Cugnaux – France

Declares that the machine indicated below:

Designation: Steam cleaner

Model: FHNVM1200

Serial number: 20240607882-20240608381

Is in conformity with the European Directives:

LVD Directive 2014/35/EU

EMC Directive 2014/30/EU

ROHS Directive: (EU) 2015/863 amending 2011/65/EU

This product is also in conformity with the following standards:

EN 60335-2-54:2008+A11:2012+A1:2015+A12:2021+A2:2021

EN 60335-1:2012+A11:2014+A13:2017+A1:2019+ A2:2019+A14:2019+A15:2021

EN 62233 :2008

EN IEC55014-1:2021

EN IEC55014-2: 2021

EN IEC 61000-3-2:2019+A1:2021

EN 61000-3-3:2013+A1:2019+A2:2021

Philippe MARIE / PDG



Cugnaux, le 21/05/2024

Responsible of technical file: M. Olivier Patriarca

11. WARRANTY

The manufacturer guarantees the product against defects in material and workmanship for a period of 5 years from the date of the original purchase. It can be extended by one year if the user subscribes to website of myswap. The warranty only applies if the product is for household use. The warranty does not cover breakdowns due to normal wear and tear.

The manufacturer agrees to replace parts identified as defective by the designated distributor. The manufacturer does not accept responsibility for the replacement of the machine, in whole or in part, and/or ensuing damage.

The warranty does not cover breakdowns due to:

- insufficient maintenance.
- abnormal assembly, adjustment or operations of the product.
- parts subject to normal wear and tear.

The warranty does not extend to:

- shipping and packaging costs.
- using the tool for a purpose other than that for which it was designed.
- the use and maintenance of the machine done in a manner not described in the user manual.

Due to our policy of continuous product improvement, we reserve the right to alter or change specifications without notice. Consequently, the product may be different from the information contained therein, but a modification will be undertaken without notice if it is recognized as an improvement of the preceding characteristic.

READ THE MANUAL CAREFULLY BEFORE USING THE MACHINE.

When ordering spare parts, please indicate the part number or code, you can find this in the spare parts list in this manual. Keep the purchase receipt; without it, the warranty is invalid. To help you with your product, we invite you to contact us by phone or via our website:

+33 (0)9.70.75.30.30

<https://services.swap-europe.com/contact>

You must create a "ticket" via the web platform.

- Register or create your account.
- Indicate the reference of the tool.
- Choose the subject of your request.
- Describe your problem.

Attach these files: invoice or sales receipt, photo of the identification plate (serial number), photo of the part you need (for example: pins on the transformer plug which are broken).



swap

12. PRODUCT FAILURE

WHAT TO DO IF MY MACHINE BREAKS DOWN?

If you bought your product in a store:

- Make sure that your machine is complete with all accessories supplied, and clean! If this is not the case, the repairer will refuse the machine.
- Go to the store with the complete machine and with the receipt or invoice.

If you bought your product on a website:

- Make sure that your machine is complete with all accessories supplied, and clean! If this is not the case, the repairer will refuse the machine.
- Create a SWAP-Europe service ticket on the site: <https://services.swap-europe.com> When making the request on SWAP-Europe, you must attach the invoice and the photo of the nameplate (serial number).

Contact the repair station to make sure it is available before dropping off the machine.

Go to the repair station with the complete machine packed, accompanied by the purchase invoice and the station support sheet downloadable after the service request is completed on the SWAP-Europe site

Please keep your original packaging to allow for after-sales service returns or pack your machine with a similar cardboard box of the same dimensions.

For any question concerning our after-sales service you can make a request on our website <https://services.swap-europe.com>

Our hotline remains available at +33 (9) 70 75 30 30.



13. WARRANTY EXCLUSIONS

THE WARRANTY DOES NOT COVER:

- Start-up and setting up of the product.
- Damage resulting from normal wear and tear of the product.
- Damage resulting from improper use of the product.
- Damage resulting from assembly or start-up not in accordance with the user manual.
- Periodic and standard maintenance events.
- Actions of modification and dismantling that directly void the warranty.
- Products whose original authentication marking (brand, serial number) has been degraded, altered or withdrawn.
- Replacement of consumables.
- The use of non-original parts.
- Breakage of parts following impacts or projections.
- Accessories breakdowns.
- Defects and their consequences linked to any external cause.
- Loss of components and loss due to insufficient screwing.
- Cutting components and any damage related to the loosening of parts.
- Overload or overheating.
- Poor power supply quality: faulty voltage, voltage error, etc.
- Damages resulting from the deprivation of enjoyment of the product during the time necessary for repairs and more generally the costs related to the immobilization of the product.
- The costs of a second opinion established by a third party following an estimate by a SWAP-Europe repair station
- The use of a product which would show a defect or a breakage which was not the subject of an immediate report and/or repair with the services of SWAP-Europe.
- Deterioration linked to transport and storage*.

* In accordance with transport legislation, damage related to transport must be declared to carriers within 48 hours maximum after observation by registered letter with acknowledgement of receipt. This document is a supplement to your notice, a non-exhaustive list.

Attention: all orders must be checked in the presence of the delivery person. In case of refusal by the delivery person, it you must simply refuse the delivery and notify your refusal.

Reminder: the reserves do not exclude the notification by registered letter with acknowledgement within 72 hours.

Information:

Thermal devices must be wintered each season (service available on the SWAP-Europe site). Batteries must be charged before being stored.

FEIDER



BUILDER SAS
32 rue Aristide Bergès - Z.I. du Casque - 31270 Cugnaux - France
Made in PRC