

# FEIDER

## MACHINES

### LOW POWER DUAL FUEL GENERATOR

MODEL: FGH3500

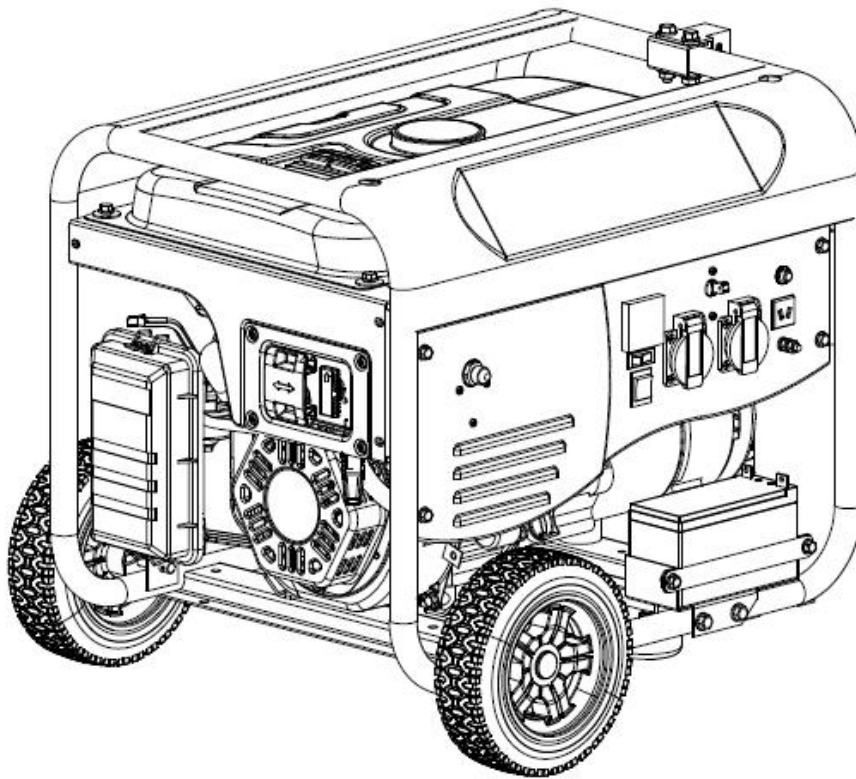

BUILDER SAS  
ZI -32, rue Aristide Bergès, 31270 Cugnaux, France  
Made in P.R.C. 2022



**Warning: Please read the manual carefully before using the unit!**



## CONTENTS

---

1. SAFETY INSTRUCTIONS.....	3
2. COMPONENT IDENTIFICATION.....	7
3. ASSEMBLY.....	8
4. OPERATION.....	13
5. MAINTENANCE AND STORAGE.....	17
6. SPECIFICATIONS.....	21
7. TROUBLESHOOTING.....	22
8. DECLARATION OF CONFORMITY.....	23
9. WARRANTY.....	24
10. PRODUCT FAILURE.....	25
11. WARRANTY EXCLUSIONS.....	26

## 1. SAFETY INSTRUCTIONS

---

- The operator must know the principles of functioning and the structure of the generator and the motor. He must know how to stop the motor in case of urgency and how to manipulate the controls.
- Never let children use this device.
- Never let people who do not know these instructions use this device. Local regulations may impose restrictions on the age of the user.
- Please do not use this device when people, especially children, or pets are nearby. Direct them away from the working area.
- The operator or the user are responsible for possible accidents or damage to other persons or to their property.
- Do not wear loose clothing or jewellery as this can get caught in the machinery as it runs.
- Use safety equipment. Wear protective gear such as an anti-dust mask, non-slip safety shoes, helmet or hearing protection.
- Stay vigilant, watch what you are doing and show good sense when you use the generator. Do not use if you are tired or under the influence of drugs, alcohol or medicines.
- Install the generator in a place that is well ventilated and make sure that there is at least 1.5 meters between the generator and the walls of the building or other equipment. Do not place flammable liquids or gases near the generator.
- Do not run the generator in an enclosed or badly-ventilated space. The exhaust gas from the motor contains carbon monoxide which is toxic and may lead to a loss of consciousness or death.
- Run the generator in respect of the power indicated in the user's manual. Do not run the generator with an overload or at excessive speed.
- The silencer of the generator becomes extremely hot when the motor runs or even for a time after it has stopped. Do not touch it as it will burn you.
- Do not transport or move the generator until it has cooled down.
- Perform periodic maintenance and resolve problems that appear immediately. Do not run the generator before correcting any fault detected.
- The generator uses a system of air-cooling, and it is necessary to clean its components regularly, including the grilles, the cover of the fan and the fan itself so as to ensure cooling.
- Keep the fuel filter clean, and change the oil of the motor regularly.
- Periodically check the installation of the connections and the tightness of the fixations, re-tightening them if necessary.
- Clean the components of the air filter periodically, and replace the air filter when necessary.
- Remove any electrical equipment that is plugged in before starting or stopping the generator.
- Before transporting the generator, you must empty the fuel tank.
- Maintenance and repair of the generator must be carried out by a qualified technician from an authorized after-sales service center.
- The adjustment points of the machine shall not be modified by the end-user. Any modification shall be done by a qualified service.
- Attention! Exhaust gases, oil and fuel are toxic. Do not operate the generator in a room without ventilation system.
- Refilling of the generating sets is not allowed during the operation.
- If the generator will be mounted in a closed room, relevant safety regulations against fire and explosion should be followed.
- Do not connect to household circuit.

- Do not use in wet condition.
- Keep in flammable away.
- Warning: when you start the generator with the cord, watch out for sudden changes in the rotation of the motor!!! Risk of wounding!!!
- Never cover the generator when it is running.
- The cut-out mounted on the generator has the aim of reducing the risk of electric shock. If it needs to be replaced with another cut-out, the latter must correspond to the technical specifications of the generator. Due to important mechanical constraints, it is necessary to use a flexible sheathed cable with a strong rubber protective layer (conforming to IEC 245-4) or a similar cable.
- When using extension lines or mobile distribution networks the resistance value shall not exceed 1,5  $\Omega$ . For reference, the total length of lines for a cross section of 1,5 mm<sup>2</sup> should not exceed 60 m; for a cross section of 2,5 mm<sup>2</sup>, this should not exceed 100 m (except the case the generating set complies with the protection feature "protection by electrical separation").

#### **Additional requirements for low-power generating sets for use by laymen**

- Protect children by keeping them at a safe distance from the generating set.
- Fuel is combustible and easily ignited. Do not refuel during operation. Do not refuel while smoking or near naked flames. Do not spill fuel.
- Some parts of the internal combustion engine are hot and may cause burns. Pay attention to the warnings on the generating set.
- Engine exhaust gases are toxic. Do not operate the generating set in unventilated rooms. When installed in ventilated rooms, additional requirements for fire and explosion protection shall be observed.
- Before use, the generating set and its electrical equipment (including lines and plug connections) should be checked to ensure that they are not defective.
- Protection against electrical shock depends on circuit breakers specially matched to the generating set. If the circuit breakers require replacement, they should be replaced with a circuit breaker having identical ratings and performances characteristics.
- Due to high mechanical stresses, only tough rubber-sheathed flexible cable (in accordance with IEC 60245-4) or the equivalent should be used.
- The user shall conform to regulations of electrical safety applicable to the place where the generating sets are used.
- The user must respect the requirements and precautions in the case of resupply by generating sets of an installation, depending on existing protective measures in this installation and applicable regulations.
- Generating sets should only be loaded up to their rated power under the rated ambient conditions.
- Prior to commencing maintenance work it shall be ensured that untimely start-up is not possible.

#### **Security measures when filling the fuel tank**

- The fuel is extremely flammable and poisonous.
- This generator only uses petrol (gasoline); any other kind of fuel will damage the motor.
- Do not overfill the tank with petrol to avoid spilling. If you notice a spill, it must be wiped up completely with a dry cloth before starting the motor.
- If you swallow fuel by mistake, if you inhale fuel vapors or if you get drops of fuel in your eyes, see a doctor immediately. If a certain quantity of fuel is spilt on your skin or clothing, wash or change your clothes.

- Always stop the motor of the generator when filling it with fuel.
- Never fill the fuel tank while smoking or near a naked flame.
- Make sure you don't spill fuel on the motor and the exhaust grille of the generator during filling with fuel.
- Keep the fuel in an appropriate recipient and sheltered from any sources of fire.
- Carry out filling in a safe place, and slowly open the fuel cap to release the pressure which has built up inside the tank. Wipe up any drops of petrol that have spilled before starting the motor.
- To prevent fire, move the generator at least 4 meters away from the area for filling with fuel.
- Make sure that the fuel cap is tightly closed before starting.
- Do not keep petrol in the tank for a long time.



- While using or transporting the generator, make sure you keep the generator upright, otherwise the fuel may escape from the carburetor or the fuel tank.



### **Electrical safety**

Before each use ensure that the load to be connected does not exceed the power of the current produced by the generator.

**To avoid electric shock, you must follow the following instructions:**

- Do not touch the generator with wet hands.
- Do not run the generator under rain or snow.
- Do not run the generator near water.
- Connect the generator to earth. Use a sufficiently thick conductor for the earth wire.
- Do not operate the generator in parallel with another generator.
- If using electrical extensions, make sure that they are sufficiently thick to transport the current and that they are used correctly.



The connection of a generator used for auxiliary power to the electrical installation of a building must be performed by a qualified electrician, and in conformity to the provisions of the applicable laws and norms in the field of electricity. Incorrect connections will cause leakage of the current from the generator into the lines of the public electricity company. Such leakage could electrocute the workers of the public electricity company working on the network or other persons in contact with the line during a power cut. Also, when the public power supply is re-established, the generator can explode, catch fire or generate fires in the building's electrical installation.



Before connecting electrical devices to the generator, make sure that their voltage specifications and frequency of functioning correspond to the technical characteristics of the generator. There may be damage if the device connected is not designed to function with a voltage tolerance of +/- 10% or a frequency tolerance of +/- 3 % compared with those of the generator.

### **Protection of the environment**

- You must periodically check the silencer (Before doing this, switch off the generator and let it cool completely). A damaged silencer increases noise.
- Do not throw motor oil into the drains but deposit it at a collection point set up for that purpose.
- The fuel for this machine is combustible and explosive. After stopping the machine, you must handle the remaining fuel correctly and meet local environmental requirements.

**FUEL SAFETY****DANGER!**

GASOLINE, GASOLINE VAPORS AND LIQUID PETROLEUM GAS (LPG: **with Propane**) ARE HIGHLY FLAMMABLE AND EXPLOSIVE.

Fire or explosion can cause severe burns or death.

Unintentional startup can result in entanglement, traumatic amputation or laceration.







**Gasoline and Gasoline Vapors (Gas):** GAS IS HIGHLY FLAMMABLE AND EXPLOSIVE.









- Gas can cause a fire or explosion if ignited.
- Gas is a liquid fuel but its vapors can ignite.
- Gas is a skin irritant and needs to be cleaned up immediately if spilled on skin or clothes.
- Gas has a distinctive odor; this will help detect potential leaks quickly.
- In any gas fire, flames should not be extinguished unless by doing so the fuel supply valve can be turned OFF. This is because if a fire is extinguished and a supply of fuel is not turned OFF, then an explosion hazard could be created.
- Gas expands or contracts with ambient temperatures. Never fill the gas tank to full capacity, as gas needs room to expand if temperatures rise.

**Liquefied Petroleum Gas (LPG: **with Propane**)**

- LPG( **with Propane**) IS HIGHLY FLAMMABLE AND EXPLOSIVE.
- Flammable gas under pressure can cause a fire or explosion if ignited.
- LPG(**with Propane**) is heavier than air and can settle in low places while dissipating.
- LPG(**with Propane**) has a distinctive odor added to help detect potential leaks quickly.
- In any petroleum gas fire, flames should not be extinguished unless by doing so the fuel supply valve can be turned OFF. This is because if a fire is extinguished and a supply of fuel is not turned OFF, then an explosion hazard could be created.
- When exchanging LPG(**with Propane**) cylinders, be sure the cylinder valve is of the same type.
- Always keep the LPG(**with Propane**) cylinder in an upright position.
- LPG(**with Propane**) will burn skin if it comes in contact with it. Keep any and all LPG(**with Propane**) away from skin at all times.

**Symbol explanation**

	Attention!
	Please read the manual carefully before using the unit!
	Conforms to relevant safety standards
	Do not dispose of old appliances with domestic rubbish.
	Guaranteed sound power level
	No naked flames

	Ground connection
	It is forbidden to run the generator in an enclosed room because exhaust emissions can lead humans or animals to coma to death.
	This symbol indicates the surface is very hot and not touching
	Keep away from the machine
	Exhaust emissions are harmful to health of body
	No naked fire near the machine!
	Do not connect with the electricity system.
	Danger! Electrical shock!

## 2. COMPONENT IDENTIFICATION

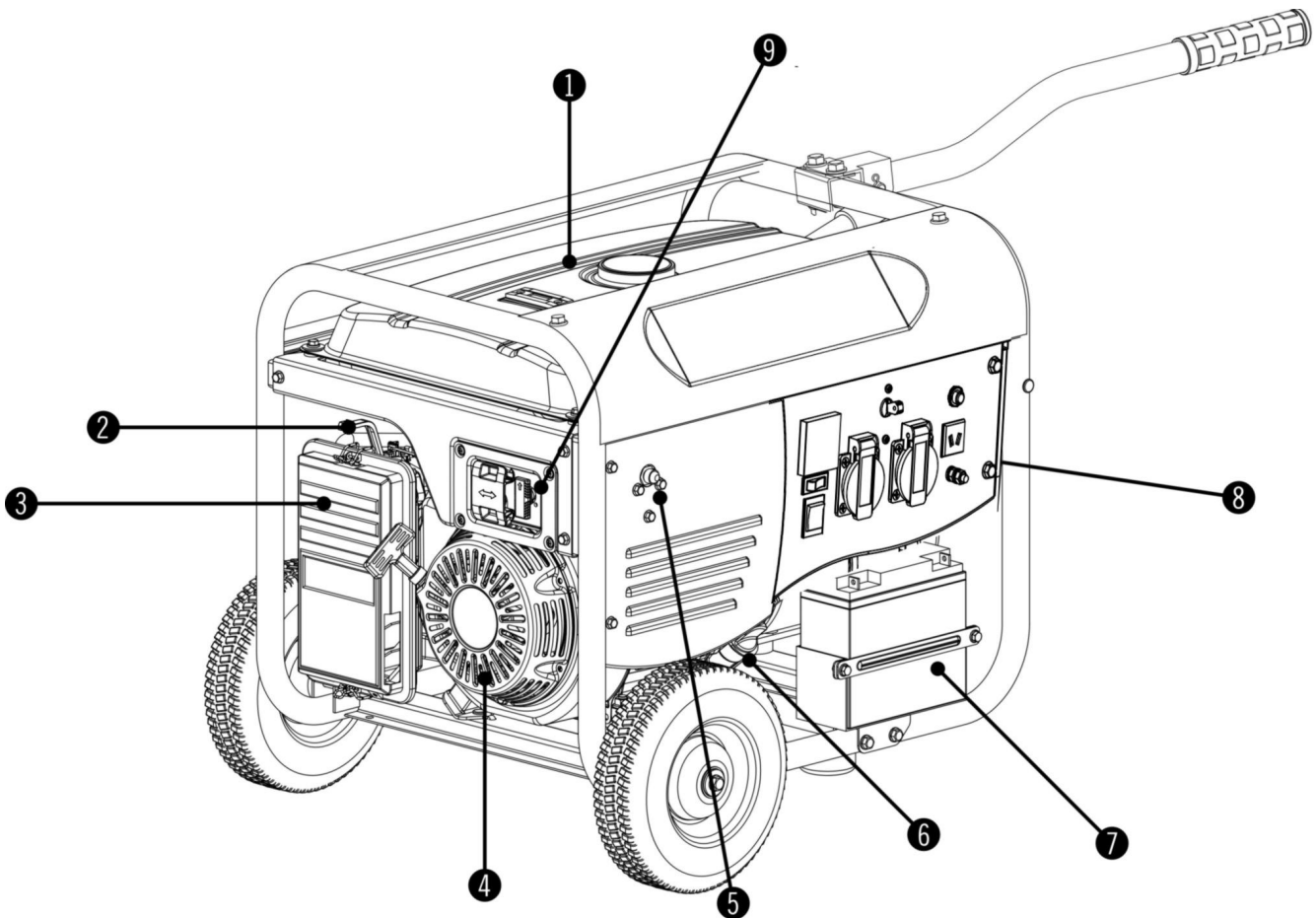

- (1) Gas Fuel Tank- 15L capacity fuel tank
- (2) Choke- Used to start the engine
- (3) Air Cleaner- Protects the engine by filtering dust and debris from the intake air
- (4) Recoil Starter- Used to manually start the engine
- (5) LPG(with Propane) Hose Connector
- (6) Oil Filler Cap- Check and fill engine oil level

- ( 7 ) Battery- Used to start the engine electrically
- ( 8 ) Power Panel- See " Power Panel " section
- ( 9 ) Fuel Selector Switch- Used to select fuel source

### 3. ASSEMBLY

---

Your generator requires some assembly. This unit is shipped from our factory without oil. It must be properly serviced with fuel and oil before operation.

#### Remove the Generator from the Shipping Carton

1. Set the shipping carton on a solid, flat surface.
2. Remove everything from the carton except the generator.
3. Carefully cut each corner of the box from top to bottom. Fold each side flat on the ground to provide a surface area to install the wheel kit and support leg.

#### Install the Wheel Kit

**CAUTION:** The wheel kit is not intended for over-the-road use.

You will need the following tools to install the wheels:

- Wheel bolt
- Needle

1. Before adding fuel and oil, tip the generator on its side.
2. Slide the Roll Pin(B) through the wheel (A) from the outside
3. Slide the Roll Pin through the mount point on the frame.
4. Secure with the R-Cilp(C).
5. Repeat the above steps to attach the second wheel.

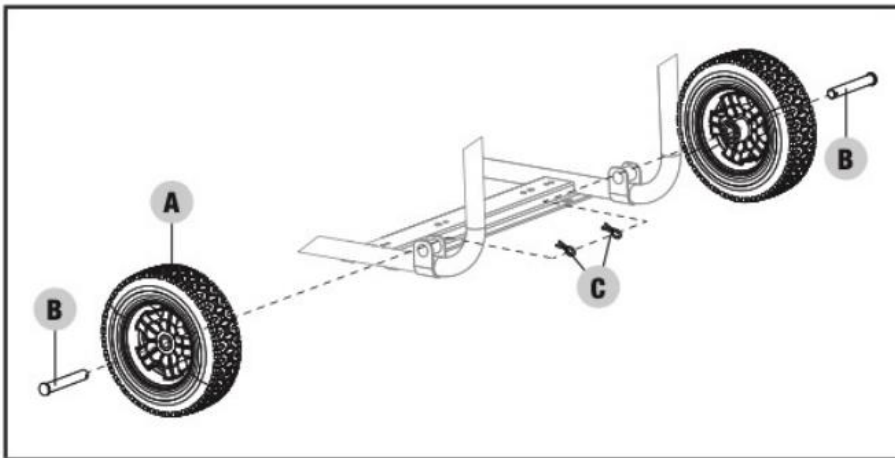

#### Install the Support Leg

1. Attach the support leg to the generator frame with flange bolt (M8x16) and flange lock nuts (M8).
2. Tip the generator slowly so that it rests on the wheels and support leg.



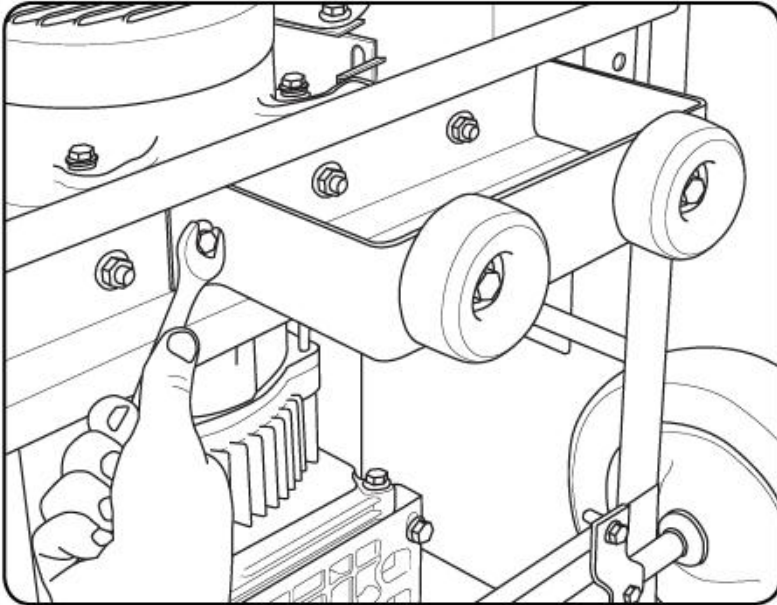

### Handle

1. Place the handle over the mounting channel on the frame
2. Secure the handle to the frame using the two flange bolts(M8x45)
3. Place a flange lock nut on the end of each bolt and fasten securely. DO NOT over tighten the flange lock nuts

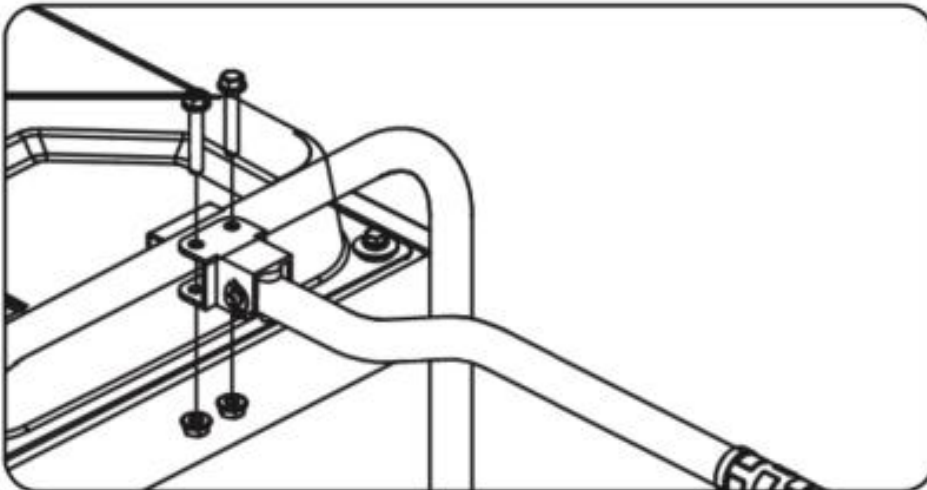

### Connect the Battery

1. Remove the protective cover from the red (+) lead on the battery.
2. Attach the red (+) lead to the red (+) terminal on the battery with the cap screw (M5x10) and secure with the nut (M5).
3. Repeat steps 1-2 for the black (-) battery lead.

### Add Engine Oil

**CAUTION:** DO NOT attempt to crank or start the engine before it has been properly filled with the recommended type and amount of oil. Damage to the generator as a result of failure to follow these instructions will void your warranty.

### NOTE:

The generator rotor has a sealed, pre-lubricated ball bearing that requires no additional lubrication for the life of the bearing.

**NOTE:**

Recommended oil type is 10W-30 automotive oil.

1. Place the generator on a flat, level surface.

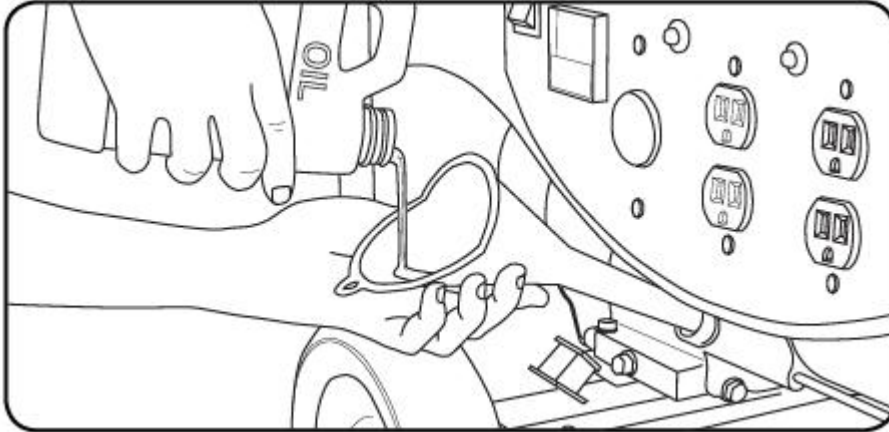

2. Remove oil fill cap/dipstick to add oil.
3. Add 0.6L of oil and replace oil fill cap/dipstick. **DO NOT OVERFILL.**
4. Check engine oil level daily and add as needed.

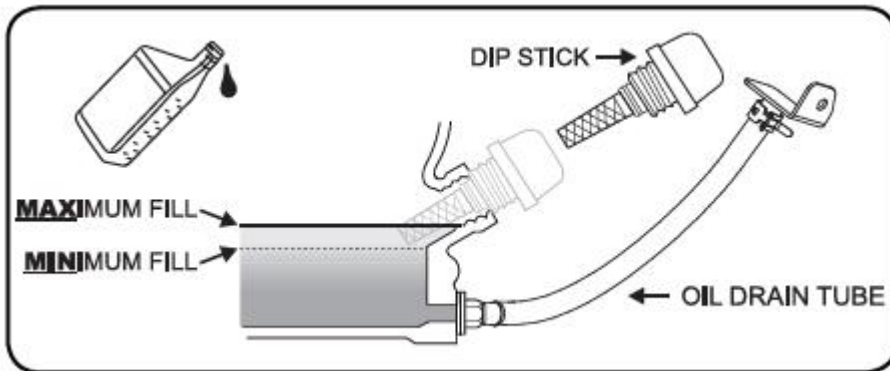

**NOTE:**

Once oil has been added, a visual check should show oil about 1-2 threads from running out of the fill hole. If using the dipstick to check oil level, DO NOT screw in the dipstick while checking.

**CAUTION**

The engine is equipped with a low oil shut-off and will stop when the oil level in the crankcase falls below the threshold level.

**NOTE:**

We consider the first 5 hours of run time to be the break-in period for the unit. During the break in period stay at or below 50% of the running watt rating and vary the load occasionally to allow stator windings to heat and cool. Adjusting the load will also cause engine speed to vary and help seat piston rings. After the 5 hour break-in period, change the oil

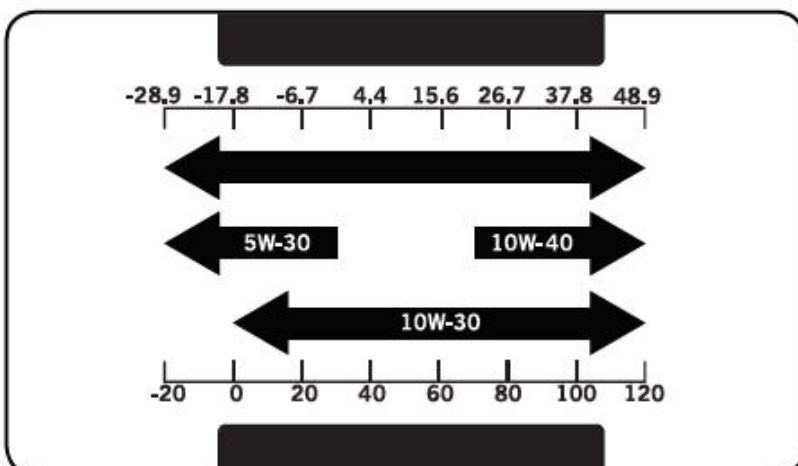

**NOTE**

Weather will affect engine oil and engine performance. Change the type of engine oil used based on weather conditions to suit the engine needs.

**NOTE**

Synthetic oil may be used after the 5-hour initial break-in period. Using synthetic oil does not increase the recommended oil change interval. Full synthetic 5W-30 oil will aid in starting in cold ambient <math><5^{\circ}\text{C}</math> (<math>41^{\circ}\text{F}</math>)

**Add Fuel (Gas)**

1. Use clean, fresh, regular unleaded fuel with a minimum octane rating of 85 and an ethanol content of less than 10% by volume.
2. DO NOT mix oil with fuel.
3. Clean the area around the fuel cap.
4. Remove the fuel cap.
5. Slowly add fuel to the tank. DO NOT OVERFILL. Fuel can expand after filling. A minimum of 1/4 in. (6.4 mm) of space left in the tank is required for fuel expansion, more than 1/4 in. (6.4 mm) is recommended. Fuel can be forced out of the tank as a result of expansion if it is overfilled, and can affect the stable running condition of the product. When filling the tank, it is recommended to leave enough space for the fuel to expand.

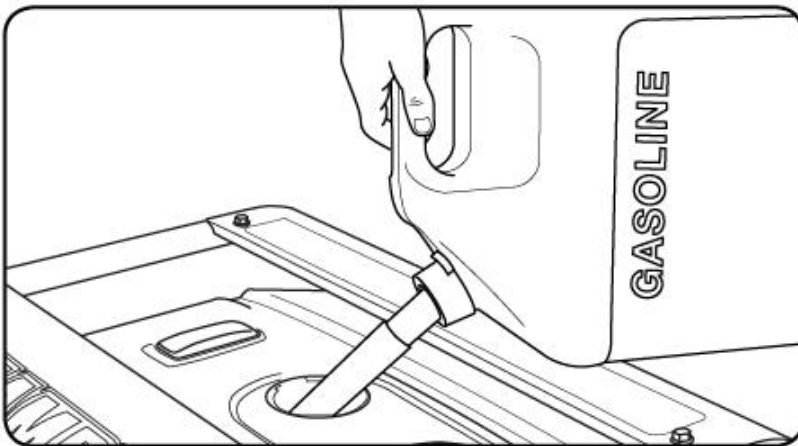

6. Screw on the fuel cap and wipe away any spilled fuel.

**CAUTION:**

Use regular unleaded gasoline with a minimum octane rating of 85.

Do not mix oil and gasoline.

Fill tank to approximately 1/4 in. (6.4 mm) below the top of the tank to allow for fuel expansion. DO NOT pump gas directly into the generator at the gas station. Use an approved container to transfer the fuel to the generator.

DO NOT fill fuel tank indoors.

DO NOT fill fuel tank when the engine is running or hot. DO NOT overfill the fuel tank.

DO NOT light cigarettes or smoke when filling the fuel tank.

**WARNING:**

Pouring fuel too fast through the fuel screen may result in blow back of fuel at the operator while filling.

**NOTE:**

Our engines work well with 10% or less ethanol blend fuels. When using blended fuels there are some issues worth noting:

— Ethanol-gasoline blends can absorb more water than gasoline alone.

— These blends can eventually separate, leaving water or a watery goo in the tank, fuel valve and carburetor.

— With gravity—fed fuel supplies, this compromised fuel can be drawn into the carburetor and cause damage to the engine and/or potential hazards.

— There are only a few suppliers of fuel stabilizer that are formulated to work with ethanol blend fuels.

— Any damages or hazards caused by using improper fuel, improperly stored fuel, and or improperly formulated stabilizers, are not covered by manufacturer's warranty.

It is advisable to always shut off the fuel supply, run the engine to fuel starvation and drain the tank when the equipment is not in use for more than 30 days.

### Connecting Liquid Petroleum Gas (LPG: with Propane) Cylinder

1. Make sure the fuel valve on the generator is in the off position.
2. Attach the LPG(with Propane) hose (included) to the LPG( with Propane) hose connector on the side of the generator and tighten with a 19 mm or adjustable wrench.

**Important: DO NOT** use tape or any other type of sealant to seal LPG(with Propane) hose connection.

3. Remove the safety plug or cap from the cylinder valve.
4. Attach the other end of the hose to the LPG(with Propane) connector on the cylinder and tighten.
5. Check all connections for leaks by wetting the fittings with a solution of soap and water. Bubbles which appear or bubbles which grow indicate that a leak exists. If a leak exists at a fitting then turn off the gas valve at the tank and tighten the fitting. Turn the gas back on and recheck the fitting with the soap and water solution. If the leak continues or if the leak is not at a fitting then do not use the generator and contact customer service.

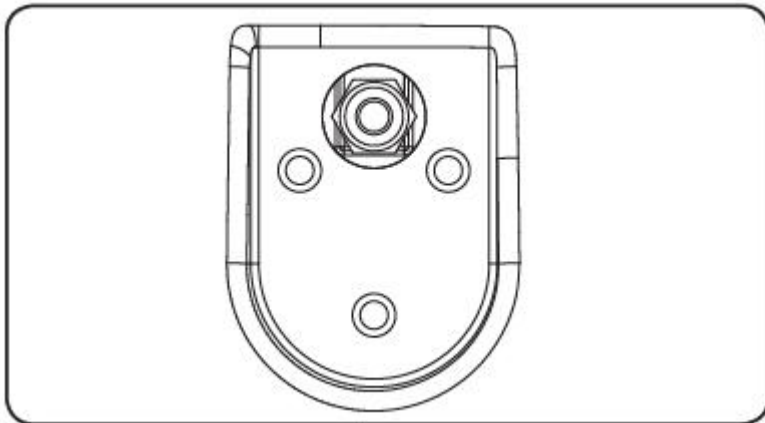

#### NOTE

- Verify the requalification date on the tank has not expired.
- All new cylinders must be purged of air and moisture prior to filling. Used cylinders that have not been plugged or kept closed must also be purged.
- The purging process should be done by a LPG(with Propane) supplier. (Cylinders from an exchange supplier should have been purged and filled properly already).
- Always position the cylinder so the connection between the valve and the gas inlet won't cause sharp bends or kinks in the hose.

#### CAUTION:

Do not allow children to tamper or play with the cylinder or hose connections.

#### CAUTION:

Use approved LPG(with Propane) cylinders equipped with an OPD (overfilling prevention device) valve. Always keep the cylinder in a vertical position with the valve on top and installed at ground level on a flat surface. Cylinders must not be installed near any heat source and should not be exposed to sun, rain, and dust. When transporting and storing, turn off the cylinder valve and fuel valve, and disconnect the cylinder. Plug the outlet, usually by a plastic protective cap, if one is available. Keep cylinders away from heat and ventilated when in a vehicle.

#### WARNING:

If there is a strong smell of gas: Close off the gas supply at the cylinder. Use soapy water, which will produce a large bubble at the point of any leak, to check the hose, and connections on the cylinder valve and the generator. Do not smoke or light a cigarette, or check for leaks using a match, open flame source or lighter. Contact a qualified technician to inspect and repair the LPG(with Propane) system if a leak is found, before using the generator.

#### Grounding

Your generator must be properly connected to an appropriate ground to help prevent electric shock.

**WARNING:**

Failure to properly ground the generator can result in electric shock.

A ground terminal connected to the frame of the generator has been provided on the power panel. For remote grounding, connect a length of heavy gauge (12 AWG minimum) copper wire between the generator ground terminal and a copper rod driven into the ground. We strongly recommend that you consult with a qualified electrician to ensure compliance with local electrical codes.

**4. OPERATION**

---

**Generator Location**

NEVER operate the generator inside any building, including garages, basements, crawl spaces and sheds, enclosure or compartment, including the generator compartment of a recreational vehicle. Please consult your local authority. In some areas, generators must be registered with the local utility. Generators used at construction sites may be subject to additional rules and regulations. Generators should be on a flat, level surface at all times. (Even while not in operation) Generators must have at least 5 ft. (1.5 m) of clearance from all combustible material. In addition to clearance from all combustible material, generators must also have at least 3 ft. (91.4 cm) of clearance on all sides to allow for adequate cooling, maintenance and servicing. Generators should never be started or operated in the back of a SUV, camper, trailer, in the bed of a truck (regular, flat or otherwise), under staircases/stairwells, next to walls or buildings, or in any other location that will not allow for adequate cooling of the generator and/or the muffler. DO NOT contain generators during operation. Allow generators to properly cool before transport or storage.

Place the generator in a well-ventilated area. DO NOT place the generator near vents or intakes where exhaust fumes could be drawn into occupied or confined spaces. Carefully consider wind and air currents when positioning generator.

Failure to follow proper safety precautions may void manufacturer's warranty.

**WARNING:** Do not operate or store the generator in rain, snow, or wet weather.

Using a generator or electrical appliance in wet conditions, such as rain or snow, or near a pool or sprinkler system, or when your hands are wet, could result in electrocution.

**WARNING**

During operation the muffler and exhaust fumes produced will become hot. If adequate cooling and breathing space are not supplied, or if the generator is blocked or contained, temperatures can become extremely heated and may lead to fire.

**Grounding**

The generator system ground connects the frame to the ground terminals on the power panel.

— The generator (stator winding) is isolated from the frame and from the AC receptacle ground pin.

— Electrical devices that require a grounded receptacle pin connection will not function if the receptacle ground pin is not functional, unless the neutral wire is bonded to the frame.

**CAUTION:**

Voltage fluctuation functioning of sense may impair the proper electronic equipment.

Electronic devices, including computers and many programmable appliances use components that are designed to operate within a narrow voltage range and may be affected by momentary voltage fluctuations. While there is no way to prevent voltage fluctuations, you can take steps to protect sensitive electronic equipment.

**Fuel Selector Switch**

The fuel selector switch on the front panel of the generator is designed specifically to choose between the fuel sources desired, Gas or LPG(**with Propane**).

To select a fuel source simply slide the switch cover to either the right or left, and this will uncover the fuel valve of the fuel selected.

The LPG(**with Propane**) fuel valve (A) is to the left of the switch cover. The gas fuel valve (B) is to the right of the switch cover.

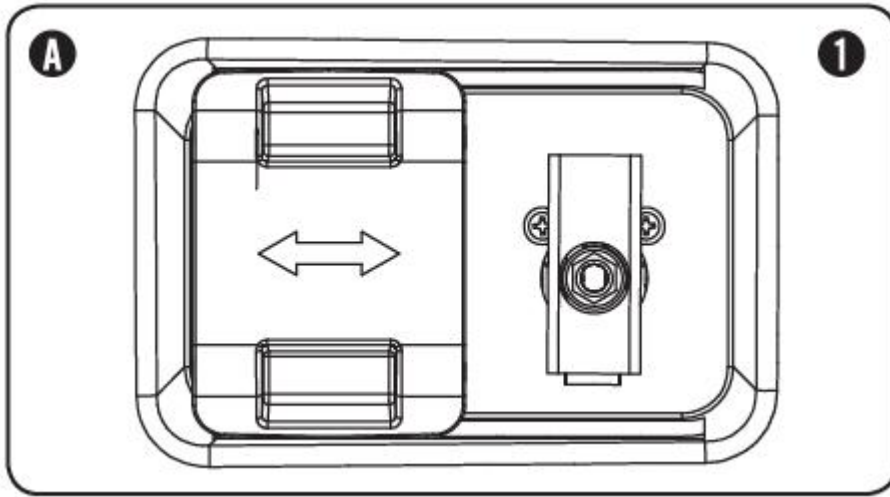

Once a fuel source has been selected, the user must turn the fuel valve to the vertical position to open the fuel valve. (1)

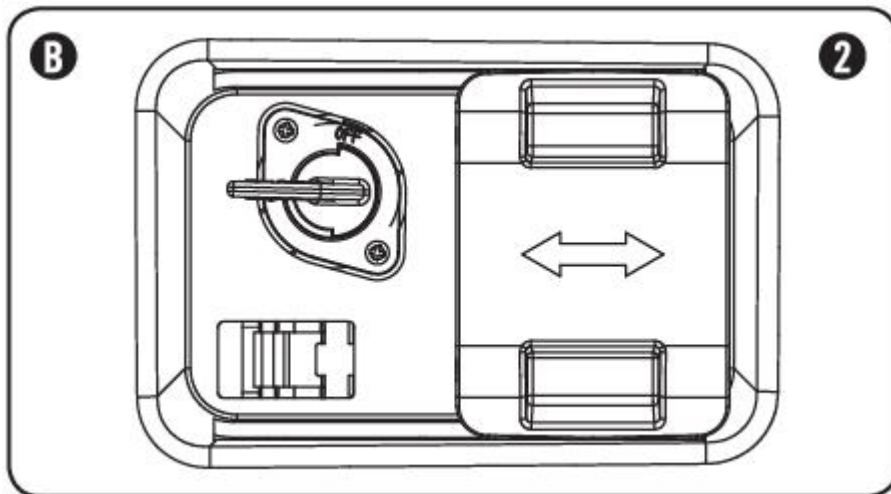

To turn a fuel valve to the off position the valve must be in the horizontal position. (2)

**NOTE**

The fuel selector switch cover is specifically designed not to slide to either side while a specific fuel has been selected and the valve is in the "ON" position. Only when the fuel valves are in the "OFF" position can the cover slide side to side.

**NOTE**

The fuel selector is locked into place once a "CLICK" sound is made. Only then can a fuel valve be turned to the vertical position.

**Starting the Engine in ambient > 15°C (59°F)**

Gasoline

1. Make certain the generator is on a flat, level surface.
2. Disconnect all electrical loads from the generator. Never start or stop the generator with electrical devices plugged in or turned on.
3. Turn the gasoline fuel valve to the "ON" position.
4. Move the choke lever to the "100% CHOKE" detent position.
  - a. For restarting a warm engine, move the choke lever to the "75% CHOKE" detent position.
5. Push the ignition switch to the "ON" position.
6. Push the battery switch to the "ON" position.
7. ELECTRIC START: Press and hold the ignition switch to the "START" position. Release as the engine begins to start, if the engine fails to start within five seconds, release the switch and wait at least ten seconds before attempting to start the engine again.
8. RECOIL START: Pull the starter cord slowly until resistance is felt and then pull rapidly.
9. Do not over-choke. As soon as engine starts, gradually move the choke lever to the "RUN" position over 2-5 second.



**NOTE:**

Keep choke lever in “Choke” position for only 1 pull of the recoil starter. After first pull, move choke lever to the “Run” position for up to the next 3 pulls of the recoil starter. Too much choke leads to sparkplug fouling/engine flooding due to the lack of incoming air. This will cause the engine not to start.

**NOTE:**

For restarts with hot engine in hot ambient > 30°C (86°F) Keep choke lever in “75% Choke” detent position for only 1 pull of the recoil starter. After first pull, move choke lever to the “Run” position for up to the next 3 pulls of the recoil starter. Too much choke leads to sparkplug fouling/engine flooding due to the lack of incoming air. This will cause the engine not to start.

**NOTE:**

For gasoline starting in cold ambient < 15°C (59°F) the choke must be in the 100% “CHOKE” detent position for both electric and recoil start procedures. Do not over-choke. As soon as engine starts, gradually move the choke lever to the “RUN” position over 5-20 second.

**LPG(with Propane)**

1. Make certain the generator is on a flat, level surface.
2. Disconnect all electrical loads from the generator. Never start or stop the generator with electrical devices plugged in or turned on.
3. Fully open the LPG(with Propane) cylinder knob.
4. Turn the LPG(with Propane) fuel valve to the “ON” position.
5. Push the ignition switch to the “ON” position.
6. Push the battery switch to the “ON” position.
7. ELECTRIC START; Move the choke lever to the 75% Choke” detent position. (A)
  - a. For restarting a warm engine, move the choke lever to the “75% CHOKE” detent position.
8. Press and hold the ignition switch to the “START” position. Release as the engine begins to start. If the engine fails to start within five seconds, release the switch and wait at least ten seconds before attempting to start the engine again.
9. Do not over-choke. As soon as engine starts, gradually move the choke lever to the “RUN” position over 2-5 second.
10. RECOIL START; Move the choke lever to the 100% Choke” detent position.
  - a. For restarting a warm engine, move the choke lever to the 100% CHOKE” detent position.
11. PULL-TO-PRIME; Pull the starter cord slowly until resistance is felt and then pull rapidly. Pull with “100% Choke” 1—2 times until you feel a few combustion pulses that indicate that the engine momentarily started.
12. Move the choke lever to the “RUN” position.
13. Pull the starter cord slowly until resistance is felt and then pull rapidly.
14. If engine fails to start in 1-pul with choke in the “RUN” , then move choke to “100% Choke” and repeat the PULL-TO-PRIME step.

**NOTE:**

For LPG(with Propane) starting in cold ambient < 15° C (59° F) Move the choke lever to the “75% Choke” detent position for electric starting and “100% Choke” for recoil start. For electric start, gradually move the choke lever to the “RUN” position over 2-10 second duration. To pull to prime for recoil start Pull with “100% Choke” 1-3 times until you feel a few combustion pulses that indicates that the engine momentarily started.

**CAUTION:** If the ignition switch is held down in the “Start” position longer than 5 seconds it could damage the starter.

**NOTE:** If the engine starts but does not run make certain that the generator is on a flat, level surface. The engine is equipped with a low oil sensor that will prevent the engine from running when the oil level falls below a critical threshold.

**NOTE:** When the battery switch is in the “ON” position, the switch will light up if the battery is sending out a charge. If the switch does not light up while in the “ON” position, check that the battery connection is still good.

**NOTE:** The supplied 12V battery does re-charge while the engine is running, but it is also recommended that the battery be fully charged at least once per month.

### Connecting Electrical Loads

1. Let the engine stabilize and warm up for a few minutes after starting
2. Plug in and turn on the desired 220—240 Volt AC single phase, 50 Hz electrical loads.
  - DO NOT connect 3-phase loads to the generator.
  - DO NOT connect 60 Hz loads to the generator.
  - DO NOT overload the generator.

### NOTE:

Connecting a generator to your electric utility company’s power lines or to another power source may be against the law. In addition this action, if done incorrectly, could damage your generator and appliances and could cause serious injury or even death to you or a utility worker who may be working on nearby power lines. If you plan to run a portable electric generator during an outage, please notify your electric utility company immediately and remember to plug your appliances directly into the generator. Do not plug the generator into any electric outlet in your home. Doing so could create a connection to the utility company power lines. You are responsible for ensuring that your generator’s electricity does not feed back into the electric utility power lines.

If the generator will be connected to a building electrical system, consult your local utility company or a qualified electrician. Connections must isolate generator power from utility power and must comply with all applicable laws and codes.

### Do Not Overload Generator Capacity

Follow these simple steps to calculate the running and starting watts necessary for your purposes.

1. Select the electrical devices you plan on running at the same time.
2. Total the running watts of these items. This is the amount of power you need to keep your items running.
3. Identify the highest starting wattage of all devices identified in step 1. Add this number to the number calculated in step 2. Surge wattage is the extra burst of power needed to start some electric driven equipment. Following the steps listed under “Power Management” will guarantee that only one device will be starting at a time.

### Power Management

Use the following formula to convert voltage and amperage to watts: Volts x Amps = Watts

To prolong the life of your generator and attached devices, follow these steps to add electrical load:

1. Start the generator with no electrical load attached
2. Allow the engine to run for several minutes to stabilize.
3. Plug in and turn on the first item. It is best to attach the item with the largest load first.
4. Allow the engine to stabilize.
5. Plug in and turn on the next item.
6. Allow the engine to stabilize.
7. Repeat steps 5—6 for each additional item.

**NOTE:** Never exceed the specified capacity when adding loads to the generator.

### NOTE:

Observing frost on LPG(with Propane) containers and regulators is common during operation and normally is not an indication of a problem. As LPG(with Propane) vaporizes and travels from the tank to the generator engine it expands. The amount of frost that forms can be affected by the size of the container, the amount of fuel being used, the humidity of the air and other operating conditions. In unusual situations this frost may eventually restrict the flow of gas to the generator resulting in deteriorating performance. For example, if the tank temperature is reduced to a very low level then the rate at which the LPG(with Propane) vaporizes is also reduced and may not provide sufficient fuel flow to the engine. This is not an



indication of a problem with the generator but only a problem with the flow of gas from the LPG(**with Propane**) container. If generator performance seems to be deteriorating at the same time that ice formation is observed on tank valve, hose or regulator then some actions may be taken to eliminate this symptom. In these rare situations it can be helpful to reduce or eliminate the cold fuel system effects by doing one of the following:

- Exchanging fuel tanks to allow the first tank to warm up, repeating as necessary
- Placing the LPG(**with Propane**) container at the end of the generator near the handle, where engine tan air flows out from the generator. This air is slightly heated by flowing over the engine. The container should not be placed in the path of the muffler outlet.
- The container can be temporarily warmed by pouring warm water over the top of the tank.

### Stopping the Engine

1. Turn off and unplug all electrical loads. Never start or stop the generator with electrical devices plugged in or turned on.
2. Let the generator run at no load for several minutes to stabilize internal temperatures of the engine and generator.
3. Turn the Fuel Valve to the "OFF" position if operating by gas.
4. Turn the LPG(**with Propane**) cylinder knob to the "CLOSE" or off position if operating by LPG(**with Propane**).
5. Let the engine run until fuel starvation has stopped the engine. This usually takes a few minutes.
6. Press the engine switch to the "OFF" position.
7. Turn battery switch to the off Position.

**Important:** Always ensure that the Fuel Valve and the Engine Switch are in the OFF position when the engine is not in use.

**NOTE:** When turning off the generator after LPG(**with Propane**) operation, make sure the LPG(**with Propane**) cylinder knob is in the fully closed position.

**NOTE:** If the engine will not be used for a period of two (2) weeks or longer, please see the Storage section for proper engine and fuel storage.

## 5. MAINTENANCE AND STORAGE

---

The owner/operator is responsible for all periodic maintenance.

**WARNING:** Never operate a damaged or defective generator.

**WARNING:** Tampering with the factory set governor will void your warranty.

**WARNING:** Improper maintenance will void your warranty.

**NOTE:** Maintenance, replacement, or repair of emission control devices and systems may be performed by any non-road engine repair establishment or individual.

Complete all scheduled maintenance in a timely manner. Correct any issue before operating the generator.

### Engine Maintenance

To prevent accidental starting, remove and ground spark plug wire before performing any service.

#### Oil

Change oil when the engine is warm. Refer to the oil specification to select the proper grade of oil for your operating environment.

1. Remove oil fill cap/dipstick.
2. Use pliers to slide the spring clamp down the oil drain hose and pull the hose off the plug bracket.
3. Point the hose into a drain pan and allow the oil to drain completely. Note: The hose end must be lower than the engine base to allow the oil to drain.
4. Replace oil drain hose onto plug bracket and slide spring clamp back into position.
5. Add 0.6L of oil and replace oil fill cap/dipstick. **DO NOT OVERFILL.**
6. Dispose of used oil at an approved waste management facility.

**NOTE:**

Once oil has been added, a visual check should show oil about 1-2 threads from running out of the fill hole. If using the dipstick to check oil level, DO NOT screw in the dipstick while checking.

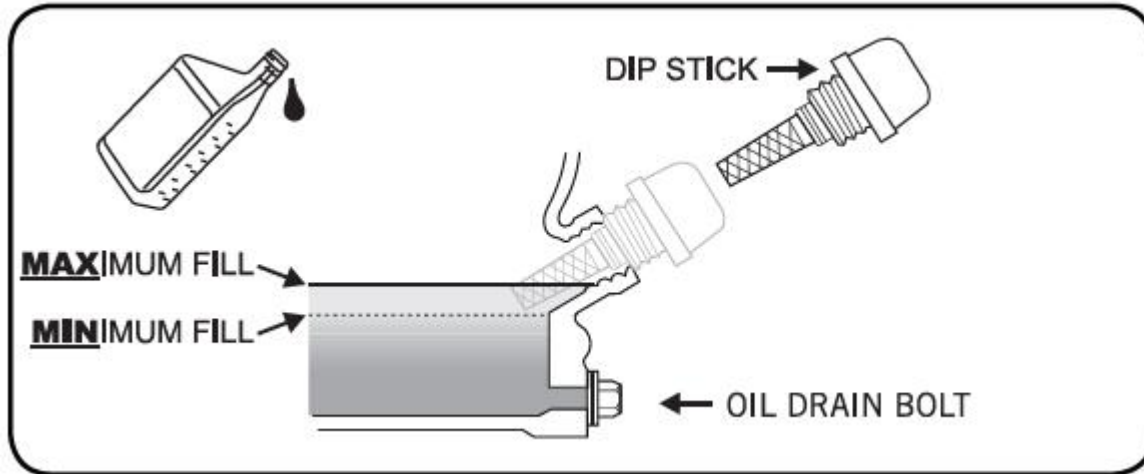
**Spark Plugs**

1. Remove the spark plug cable from the spark plug.
2. Use the spark plug tool that shipped with your generator to remove the plug.
3. Inspect the electrode on the plug. It must be clean and not worn to produce the spark required for ignition.
4. Make certain the spark plug gap is 0.7 - 0.8 mm or (0.028 - 0.031 in.).
5. Refer to the spark plug recommendation chart when replacing the plug.
6. Carefully thread the plug into the engine.
7. Use the spark plug tool to firmly install the plug.
8. Attach the spark plug wire to the plug.

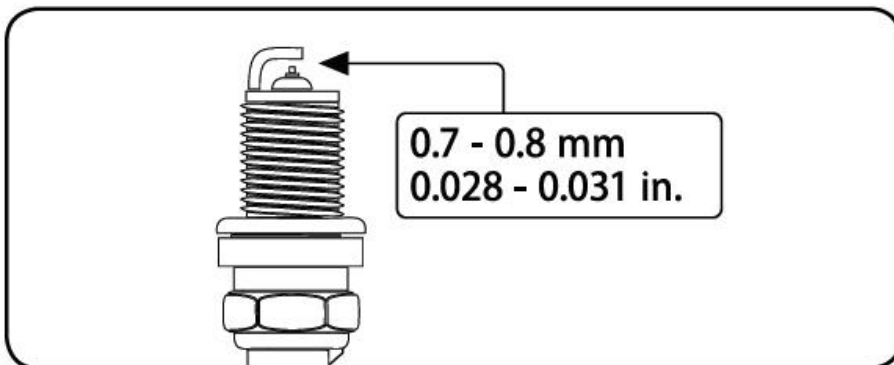
**Air Filter**

1. Remove the snap on cover holding the air filter to the assembly.
2. Remove the foam element.
3. Wash in liquid detergent and water. Squeeze thoroughly dry in a clean cloth.
4. Saturate in clean engine oil.
5. Squeeze in a clean, absorbent cloth to remove all excess oil.
6. Place the filter in the assembly.
7. Reattach the air filter cover and snap in place.

**Spark Arrester**

1. Allow the engine to cool completely before servicing the spark arrester
2. Remove the three screws holding the cover plate which retains the end of the spark arrester to the muffler
3. Remove the spark arrester screen
4. Carefully remove the carbon deposits from the spark arrester screen with a wire brush
5. Replace the spark arrester if it is damaged

6. Position the spark arrester in the muffler and attach with the three screws

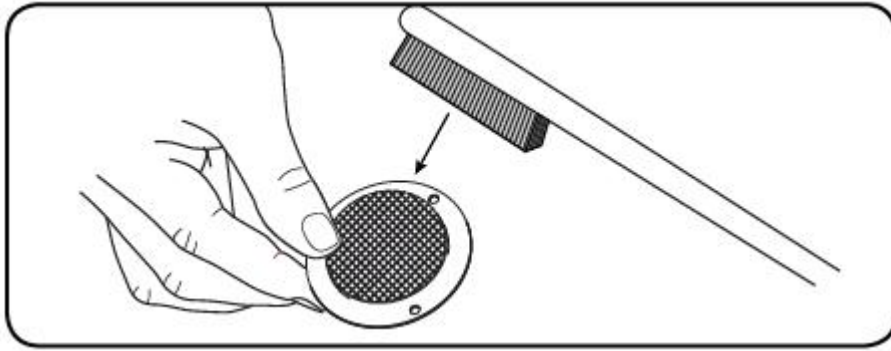

**CAUTION:** Failure to clean the spark arrester will result in degraded engine performance

**Cleaning**

**CAUTION:** DO NOT spray engine with water. Water can contaminate the fuel system

Use a damp cloth to clean exterior surfaces of the engine.

Use a soft bristle brush to remove dirt and oil

Use an air compressor (25 PSI) to clear dirt and debris from the engine.

**Adjustments**

The air-fuel mixture is not adjustable. Tampering with the governor can damage your generator and your electrical devices and will void your warranty.

**Maintenance Schedule**

Follow the service intervals indicated in the following maintenance schedule.

Service your generator more frequently when operating in adverse conditions.

**CAUTION:**

DO NOT use a garden hose to clean the generator. Water can enter the generator through the cooling slots and damage the generator windings.

Use a damp cloth to clean exterior surfaces of the engine.

Use a soft bristle brush to remove dirt and oil

Use an air compressor (25 PSI) to clear dirt and debris from the engine.

Every 8 hours or daily	
	Check oil level
	Clean around air intake and muffler
	Check hose for leaks
First 5 hours	
	Change oil
Every 50 hours or every season	
	Clean air filter
	Change oil if operating under heavy load or in hot environments
Every 100 hours or every season	
	Change oil
	Clean/adjust spark plug
	Check/adjust valve clearance*
	Clean spark arrester
	Clean fuel tank and filter*

Every 250 hours	
	Clean combustion chamber*
Every 3 years	
	Replace fuel line and LPG(with Propane) hose

\*To be performed by knowledgeable, experienced owners or Hyundai certified dealers.

### Generator Maintenance

Make certain that the generator is kept clean and stored properly. Only operate the unit on a flat, level surface in a clean, dry operating environment. DO NOT expose the unit to extreme conditions, excessive dust, dirt, moisture or corrosive vapors.

### Storage

The generator should be started at least once every 14 days and allowed to run for at least 20 minutes. For longer term storage, please follow these guidelines.

### Generator Storage

1. Add a properly formulated fuel stabilizer to the tank.
2. Be sure all appliances are disconnected from the generator.
3. Run the generator for a few minutes so the treated fuel cycles through the fuel system and carburetor.
4. Turn the fuel valve to the "Off" position.
5. Let the generator run until fuel starvation has stopped the engine. This usually takes a few minutes.
6. The generator needs to cool completely before cleaning and storage.
7. Remove the spark plug cap, then pull the recoil grip 3 times to drain the gasoline from the carburetor jets.
8. Change the engine oil.
9. Remove the spark plug and pour about a tablespoon of oil into the cylinder. Crank the engine slowly to distribute the oil and lubricate the cylinder.
10. Reattach the spark plug.
11. Store the unit in a clean, dry place out of direct sunlight.



### DANGER!

Generator exhaust contains odorless and colorless carbon monoxide gas.

To avoid accidental or unintended ignition of your remote start generator during periods of storage the following precautions should be followed:

When storing the generator for short periods of time make sure that the Ignition Switch, the Fuel valve and the Battery Switch are set in the OFF position.

When storing the generator for extended periods of time make sure that the Ignition Switch, the Fuel Valve and the Battery Switch are set in the OFF position and the battery leads have been disconnected from the battery

### Generator Battery

This product is equipped with an automatic battery charging circuit. The battery will receive charging voltage when the engine is running. The battery maintain a proper charge if the unit is used on a regular basis (about once every two weeks). If it is used less frequently, the battery should be connected to a trickle charger or battery maintainer to keep the battery properly charged. If the battery is not able to start the engine, it can be started by manually pulling the engine recoil cord. If the battery voltage is extremely low, the charging circuit may not be able to re-charge the battery. In this case, the battery must be connected to a standard automotive style battery charger for re-charging before it can be used

### Disconnect the Battery

1. Remove the protective cover from the black / negative battery lead
2. Disconnect the black / negative lead from the black /negative terminal on the battery and store the cap

screw (M5x10) and nut (M5)

3. Repeat steps 1-2 for the red / positive battery lead

4. Store the battery in a cool, dry place.

### Charge the Battery

For a generator equipped with batteries for electric starting, proper battery maintenance and storage should be followed, An automatic battery charger (not included with automatic trickle charging capability should be used to charge the battery, Maximum charging rate should not exceed 1.5 amps. Follow the instructions included with the battery charger. The battery should be fully charged at least once per month.

**NOTE:** A Float Charger will maintain the battery condition over long storage periods.

## 6. SPECIFICATIONS

Engine	Engine model	YF172FD
	Engine type	Single cylinder, 4-strokes, Forced air cooling, OHV.
	Displacement( CC)	224cc
	Rated speed	5.0kW@ 3600/min
	Igniting system	TCI
	Starting system	Electric /Recoil
	Fuel Volume (L)	15 L
	Continuous operation time (h)	8 h
	Min. Fuel consumption (g/kW.h)	360 g/kW.h
	Lube. Oil capacity (L)	0.6 L
	Sound pressure level: L <sub>pA</sub>	75.05 dB(A)
	Sound power level L <sub>wA</sub>	96.17 dB(A)
	Incertitude	K = 1,12dB(A)
	Guaranteed sound power level	96 dB(A)
Generator SET Generator set	AC output Voltage	230 V~
	AC Frequency	50 Hz
	AC rated output power (Gasoline)	(COP)3.0kW
	AC max output power (Gasoline)	3.2kW max
	AC rated output power (COP) (LPG:with Propane)	(COP)2.7kW
	AC max output power (LPG: with Propane)	2.9kW max
	Power factor	1.0
	Rated AC output current	13.0A (Gasoline) 11.7A (LPG: with Propane)
	Performance class	G1
	Quality class	A
	Max. temperature	40°C
	Max. altitude	1000m
	Protection class	IP23M
	DC output	12V /8.3A
	Size (LxWxH)	710×475×490
Net weight	54.7kg	
Information for regulator	Regulator	Inlet connection : G2 (W21.7x1.814-G2-R5F )nut Outlet: H1(M20x150)

& hose of LPG(with Propane)		Capacity: 1,5 kg/h Outlet pressure: 37 Mbar With French instruction NF approval
	Hose	NF gas hose in rubber acc.to NF XPD36-112 Length=0.75M With REACH certificate phthalate concentration+/-5%

### Spark Plugs

**OEM spark plug:** NHSP F6RTC

**Replacement spark plug:** NGK BPR6ES or equivalent Make certain the spark plug gap is 0.7 - 0.8 mm or (0.028 - 0.031 in.).

### Maintenance Valve Clearance

- Intake: 0.13 - 0.17 mm (0.005 - 0.007 in.)
- Exhaust: 0.18 - 0.22 mm (0.003 - 0.006 in.)

### An Important Message about Temperature

Your HYUNDAI product is designed and rated for continuous operation at ambient temperatures up to 40°C (104°F). When your product is needed your product may be operated at temperatures ranging from -15°C (5°F) to 50°C (122°F) for short periods. If the product is exposed to temperatures outside this range during storage, it should be brought back within this range before operation. In any event, the product must always be operated outdoors, in a well-ventilated area and away from doors, windows and other vents.

## 7. TROUBLESHOOTING

Problem	Cause	Solution
Generator will not start	No fuel	Add fuel
	Faulty spark plug	Replace spark plug
	Unit loaded during start up	Remove load from unit
Generator starts but runs roughly	Low oil level	Fill crankcase to the proper level Place generator on a flat, level surface
	Choke in the wrong position	Adjust choke
	Spark plug wire loose	Attach wire to spark plug
Generator shuts down during operation	Out of fuel	Fill fuel tank
	Low oil level	Fill crankcase to the proper level. Place generator on a flat, level surface
Generator cannot supply enough power or overheating	Generator is overloaded	Review load and adjust. See "Power Management"
	Insufficient ventilation	Check for air restriction. Move to a well-ventilated area
No AC output	Cable not properly connected	Check all connections
	Connected device is defective	Replace defective device
	Circuit breaker is open	Reset circuit breaker
	Loose wiring	Inspect and tighten wiring connections
	Other	Contact the help line
Repeated circuit breaker tripping	Overload	Review load and adjust. See "Power Management"
	Faulty cords or device	Check for damaged, bare or frayed wires. Replace defective device

## 8. Declaration of conformity

---



BUILER SAS  
ZI, 32 RUE ARISTIDE BERGES – 312070 CUGNAUX – FRANCE

Declares that the machinery designated below:  
LOW POWER DUAL FUEL GENERATOR  
Model: FGH3500

Serial number: 20221229055-20221229104

Complies with the provisions of the Directive “machinery” 2006/42/CE and national laws transposing it:

Also complies with the following European directives:

EMC Directive 2014/30/EU

ROHS Directive (EU) 2015/863 amending 2011/65/EU

Emission directive (EU) 2016/1628 & 2017/656/EU

Noise directive 2000/14/CE Annex VI + 2005/88/CE

Also complies with European standards, with national standards and the following technical provisions:

EN ISO 8528-13:2016

EN ISO 12100:2010

EN 55012:2007/A1:2009

EN 61000-6-1:2007

Notified body of noise certificate:

ISET S.r.l. Via Donatori del Sangue, 9 46024 - Moglia (MN) Italy  
NB 0865

Measured sound power level LwA:96.17 dB

Guaranteed Sound power level: 96 dB(A)

Responsible for the technical file: Michel Krebs

Cugnaux, 18/11/2022

Philippe MARIE / PDG

## 9. WARRANTY



### WARRANTY

The manufacturer guarantees the product against defects in material and workmanship for a period of 2 years from the date of the original purchase. The warranty only applies if the product is for household use. The warranty does not cover breakdowns due to normal wear and tear.

The manufacturer agrees to replace parts identified as defective by the designated distributor. The manufacturer does not accept responsibility for the replacement of the machine, in whole or in part, and/or ensuing damage.

**The warranty does not cover breakdowns due to:**

- insufficient maintenance.
- abnormal assembly, adjustment or operations of the product.
- parts subject to normal wear and tear.

**The warranty does not extend to:**

- shipping and packaging costs.
- using the tool for a purpose other than that for which it was designed.
- the use and maintenance of the machine done in a manner not described in the user manual.

Due to our policy of continuous product improvement, we reserve the right to alter or change specifications without notice. Consequently, the product may be different from the information contained therein, but a modification will be undertaken without notice if it is recognized as an improvement of the preceding characteristic.

**READ THE MANUAL CAREFULLY BEFORE USING THE MACHINE.**

When ordering spare parts, please indicate the part number or code, you can find this in the spare parts list in this manual. Keep the purchase receipt; without it, the warranty is invalid. To help you with your product, we invite you to contact us by phone or via our website:

- **+33 (0)9.70.75.30.30**
- **<https://services.swap-europe.com/contact>**

You must create a "ticket" via the web platform.

- Register or create your account.
- Indicate the reference of the tool.
- Choose the subject of your request.
- Describe your problem.
- Attach these files: invoice or sales receipt, photo of the identification plate (serial number), photo of the part you need (for example: pins on the transformer plug which are broken).





# 10. PRODUCT FAILURE

## WHAT TO DO IF MY MACHINE BREAKS DOWN?

### **If you bought your product in a store:**

a) Empty the fuel tank if your product has one.

b) Make sure that your machine is complete with all accessories supplied, and clean! If this is not the case, the repairer will refuse the machine.

Go to the store with the complete machine and with the receipt or invoice.

### **If you bought your product on a website:**

a) Empty the fuel tank if your product has one.

b) Make sure that your machine is complete with all accessories supplied, and clean! If this is not the case, the repairer will refuse the machine.

c) Create a SWAP-Europe service ticket on the site: <https://services.swap-europe.com> When making the request on SWAP-Europe, you must attach the invoice and the photo of the nameplate (serial number).

d) Contact the repair station to make sure it is available before dropping of the machine.

Go to the repair station with the complete machine packed, accompanied by the purchase invoice and the station support sheet downloadable after the service request is completed on the SWAP-Europe site

For machines with engine failure from manufacturers BRIGGS & STRATTON, HONDA and RATO, please refer to the following instructions.

Repairs will be done by approved engine manufacturers of these manufacturers, see their site:

- <http://www.briggsandstratton.com/eu/fr>
- <http://www.honda-engines-eu.com/fr/service-network-page;jsessionid=5EE8456CF39CD572AA2AEEDFD290CDAE>
- <https://www.rato-europe.com/it/service-network>

**Please keep your original packaging to allow for after-sales service returns or pack your machine with a similar cardboard box of the same dimensions.**

**For any question concerning our after-sales service you can make a request on our website <https://services.swap-europe.com>**

**Our hotline remains available at +33 (9) 70 75 30 30.**



# 11. WARRANTY EXCLUSIONS

## THE WARRANTY DOES NOT COVER:

- Start-up and setting up of the product.
- Damage resulting from normal wear and tear of the product.
- Damage resulting from improper use of the product.
- Damage resulting from assembly or start-up not in accordance with the user manual.
- Breakdowns related to carburetion beyond 90 days and fouling of carburetors.
- Periodic and standard maintenance events.
- Actions of modification and dismantling that directly void the warranty.
- Products whose original authentication marking (brand, serial number) has been degraded, altered or withdrawn.
- Replacement of consumables.
- The use of non-original parts.
- Breakage of parts following impacts or projections.
- Accessories breakdowns.
- Defects and their consequences linked to any external cause.
- Loss of components and loss due to insufficient screwing.
- Cutting components and any damage related to the loosening of parts.
- Overload or overheating.
- Poor power supply quality: faulty voltage, voltage error, etc.
- Damages resulting from the deprivation of enjoyment of the product during the time necessary for repairs and more generally the costs related to the immobilization of the product.
- The costs of a second opinion established by a third party following an estimate by a SWAP-Europe repair station
- The use of a product which would show a defect or a breakage which was not the subject of an immediate report and/or repair with the services of SWAP-Europe.
- Deterioration linked to transport and storage\*.
- Launchers beyond 90 days.
- Oil, petrol, grease.
- Damages related to the use of non-compliant fuels or lubricants.

\* In accordance with transport legislation, damage related to transport must be declared to carriers within 48 hours maximum after observation by registered letter with acknowledgement of receipt.

This document is a supplement to your notice, a non-exhaustive list.

**Attention:** all orders must be checked in the presence of the delivery person. In case of refusal by the delivery person, it you must simply refuse the delivery and notify your refusal.

**Reminder:** the reserves do not exclude the notification by registered letter with acknowledgement within 72 hours.

### Information:

Thermal devices must be wintered each season (service available on the SWAP-Europe site). Batteries must be charged before being stored.