

ORIGINAL INSTRUCTIONS

FEIDER
MACHINES

ELECTRIC LOGSPLITTER

FFBE5TS-UK

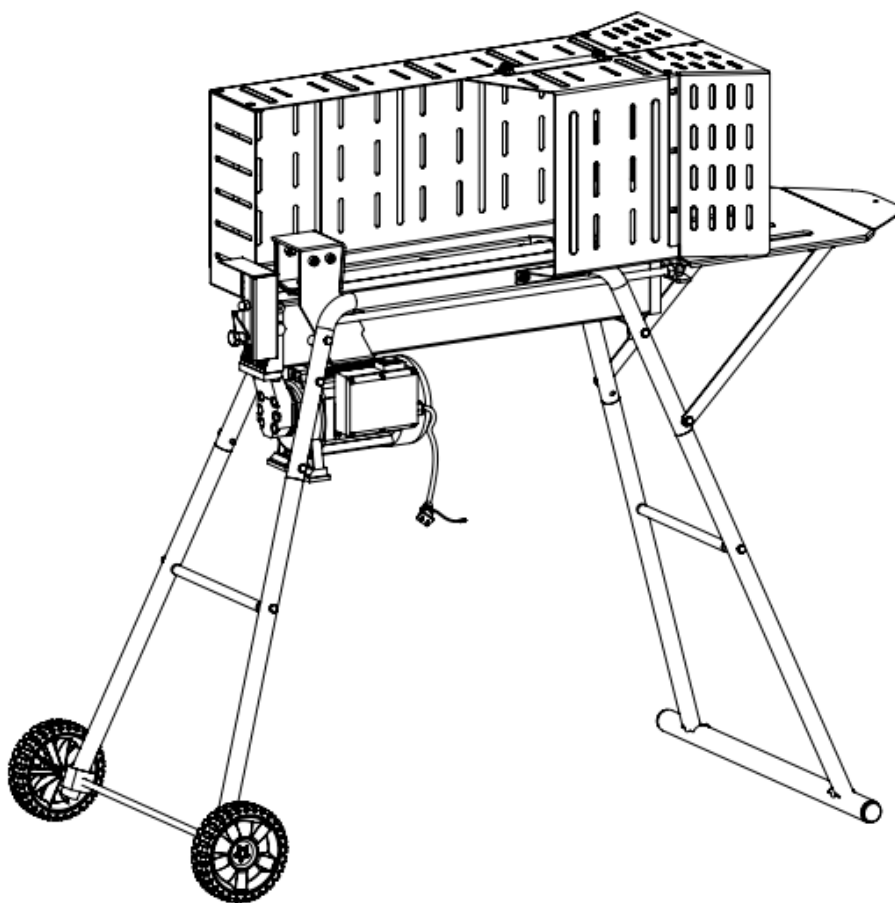

READ THIS INSTRUCTIONS MANUAL BEFORE USING THE TOOL

FEIDER 32, rue Aristide Bergès - ZI 31270 Cugnaux – France Made in PRC 2019



Danger! Keep clear of moving parts!
To be operated by one person only!
The log splitter must be used horizontally, can't be used vertically.

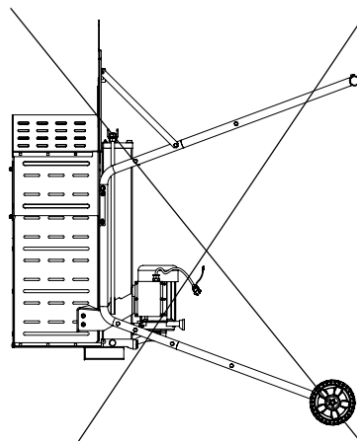
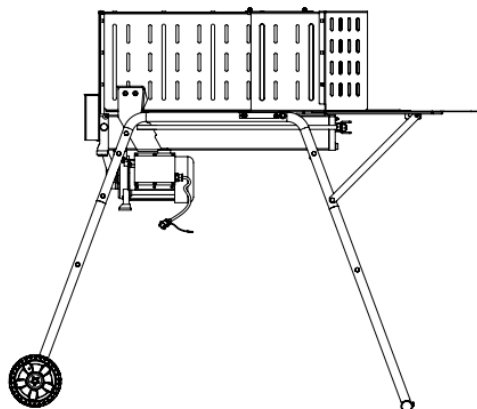

SAFETY WARNINGS

SAFETY WARNINGS & INSTRUCTIONS

SYMBOL AFFIXED TO
THE MACHINE

● UNDERSTAND YOUR LOG SPLITTER

Read and understand the owner's manual and labels affixed to the log splitter. Learn its application and limitations as well as the specific potential hazards peculiar to it.

● DRUGS, ALCOHOL AND MEDICATION

Do not operate the log splitter while under the influence of drugs, alcohol, or any medication that could affect your ability to use it properly.

● AVOID DANGEROUS CONDITIONS

Put the log splitter on a 60 - 75cm high, stable, flat, and level work bench where there is plenty of room for handling, and help the operator stay alert. Bolt the log splitter to the work surface if it tends to slip, walk, or slide.

Keep your work area clean and well lighted. Cluttered areas invite injuries.

Do not use the log splitter in wet or damp areas or expose it to rain.

Do not use it in areas where fumes from paint, solvents or flammable liquids pose a potential hazard.



● INSPECT YOUR LOG SPLITTER

Check your log splitter before turning it on. Keep guards in place and in working order. Form -a habit of checking to see that keys and adjusting wrenches are removed from tool area before turning it on. Replace damaged, missing or failed parts before using it.

● DRESS PROPERLY

Do not wear loose clothing, gloves, neckties or jewelry (rings, wrist watches). They can be caught in moving parts.

Protective electrically non-conductive gloves and non-skid footwear are recommended when working. Wear protective hair covering to contain long hair, preventing it from get caught in machinery.

● PROTECT YOUR EYES AND FACE

Any log splitter may throw foreign objects into the eyes. This can cause permanent eye damage. Always wear safety goggles. Everyday eyeglasses have only impact resistant lenses. They are not safety glasses.

Do not put the log splitter on the ground for operations. This is awkward operating position that the operator has to bring his face close to the machine, and thus risks being struck by wood chips or debris.

● EXTENSION CORDS

Improper use of extension cords may cause inefficient operation of the log splitter which can result in overheating. Be sure the extension cord is no longer than 10m and its section is no less than 2.5mm² to allow sufficient current flow to the motor.

Avoid use of free and inadequately insulated connections. Connections must be made with protected material suitable for outdoor use.

● AVOID ELECTRICAL SHOCK

Check that the electric circuit is adequately protected and that it corresponds with the power, voltage and frequency of the motor. Check that there is a ground connection, and a regulation differential switch upstream.

Ground the log splitter. Prevent body contact with grounded surfaces: pipes, radiators, ranges, and refrigerator enclosures.

Never open the pushbutton box on the motor. Should this be necessary, please contact a qualified electrician.

Mark sure your fingers do not touch the plug's metal prongs when plugging or unplugging the log splitter.



● KEEP VISITORS AND CHILDREN AWAY

The log splitter must be always operated by one person only. Other people should keep a safe distance from the work area, especially when the log splitter is under operations. Never use another people to help you with freeing jammed log.



● INSPECT YOUR LOG

Make sure there are no nails or foreign objects in logs to be split. The ends of the logs must be cut square. Branches must be cut of flush with the trunk.

● DON'T OVERREACH

Floor must not be slippery.

Keep proper footing and balance at all times.

Never stand on log splitter. Serious injury could occur if the tool is tipped or if the cutting tools is unintentionally contacted. Do not store anything above or near the log splitter where anyone might stand on the tool to reach them.

● AVOID INJURY FROM UNEXPECTED ACCIDENT

Always pay full attention to the movement of the log pusher.

Do not attempt to load the log on until the log pusher has stopped.

Keep hands out of the way of all moving parts.

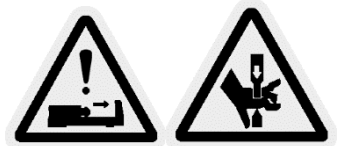

● PROTECT YOUR HANDS

Keep you hands away from splits and cracks which open in the log; They may close suddenly and crush or amputate your hands. Do not remove jammed logs with you hands.



● DON'T FORCE TOOL

It will do a better and safer job at its design rate. Never try to split logs larger than those indicated in the specifications table. This could be dangerous and may damage the machine.

Don't use log splitter for a purpose for which it was not intended.

● NEVER LEAVE TOOL RUNNING UNATTENDED

Don't leave tool until it has come to a complete stop.

● DISCONNECT POWER

Unplug when not in use, before making adjustments, changing parts, cleaning, or working on the log splitter; Consult technical manual before servicing.



● PROTECT THE ENVIRONMENT

Take used oil to an authorized collection point or follow the stipulations in the country where the log splitter is used.

Do not discharge into drains, soil or water.



● MAINTAIN YOUR LOG SPLITTER WITH CARE

Keep the log splitter clean for best and safest performance.

● **MAKE THE WORKSHOP CHILDPROOF**

Lock the shop. Disconnect master switches. Store the log splitter away from children and others not qualified to use it.

Symbols



WARNING! Electricity - Risk of electric shock.



Warning: Floor-level obstacle



Warning: Risk of slipping



No smoking in the working area



The log splitter must be always operated by one person only. Never use another people to help you with freeing jammed log.

1. The log splitter must always be used by one operator only.
2. Nobody must be allowed to use the log splitter unless they have read the instruction manual and have been instructed in the regulations to follow for correct and safe use.
Operators must receive necessary training and instructions.

3. The machine must be used by adults only. Use of the log splitter by apprentices of not less than 16 years of age must be supervised by an adult authorized to use the machine.
4. Never wear loose, unbuttoned clothing which may become trapped in moving parts.
5. Check that the logs to be split are free from nails or wire, which may fly up or damage the machine, the ends of the logs must be cut square, branches must be cut off flush with the trunk.
6. Never try to split logs larger than those indicated in the technical specifications. This could be dangerous and may damage the machine.
7. Break wood in the direction of the grain, do not place wood across the log splitter and leave it in that position for splitting; it may be dangerous and may seriously damage the machine.
8. Never attempt to cut two logs at once, one may fly up and hit you.
9. If the log moves away from the blade, retract the blade and turn the log through 90°.
10. Do not attempt to load the log in the log splitter while the blade is in motion, you could get trapped and injured.
11. Keep your hands well away from any splits and cracks which open in the log; these may close suddenly and crush or amputate your fingers.
12. Never force the log splitter for more than 5 seconds keeping the cylinder under pressure in the attempt to split excessively hard wood. After this time interval, the oil under pressure is overheated and the machine could be damaged. It is thus better to stop and rotate the log by 90° to see whether it can be split in a different position. In any case, if you are not able to split the log, this means that its hardness exceeds the capacity of the machine and thus that log should be discarded so as not to damage the log splitter.
13. Do not force the blade by pushing the log on the upper part, as this can cause the blade to break or damage the body of the machine. Always set the log on the guides.
14. Never leave the machine unattended while it is running. If you leave the machine, even for a short time, remove the power supply or any possible cause of accidental start-up.
15. The log splitter must never be used by an operator who is under the influence of alcohol, drugs, medicines, or who is tired. A clear mind is essential for safety.
16. Never request the assistance of another person to help you remove a jammed log.
17. Do not use machines with electric motor if natural gas, petrol fumes or other inflammable vapors are present.
18. Check that the electric circuit is adequately protected and that it corresponds with the power, voltage and frequency of the motor, check that there is a ground connection, and a regulation differential switch upstream. Check on the functioning of the machine.

19. Never open the switch box on the motor. Should this be necessary, contact a qualified electrician.
20. Make sure that the machine and the cable never come in contact with water.
21. Treat the power cable with care, do not attempt to move the machine by pulling the cable, do not yank the cable to unplug it; keep the cable away from excessive heat, oil and sharp objects.
22. Never leave the machine unattended with the power supply "on", also disconnect the power cable when not in use, when carrying out maintenance work, when changing attachment or moving the machine.
23. Before starting work, hydraulic pipes and hoses shall be inspected and the stopping devices shall be tested.
24. Keep the working area free from obstructions, e.g. logs, split wood etc.
25. Stop the machine before cleaning or making adjustments.
26. The hazards may arise from particular characteristics of wood when being split (e.g. knots, logs of irregular shape etc.)
27. Operator must receive necessary training and instruction from a qualified person before handling the tool.
28. Use the tool only for the intended use. Misuse (such using material other than log) can damage the tool and cause accidents and injuries.
29. The splitting operation of the machine is designed to be activated by one person. While there is the possibility that additional operators could be working with the machine (e.g. for loading and unloading), only one operator should activate splitting operations.
30. The machine shall not be used by children.
31. Wear suitable personal protective equipment (PPE), including safety footwear; close fitting clothing and suitable work gloves, eye protection and hearing protection.
32. Before starting work, hydraulic pipes and hoses shall be inspected and the stopping devices shall be tested.
33. Tests of the machine's safety devices before use the tool. If safety devices do not work properly, do not use the tool and bring it to a qualified technician for inspection and repair.
34. The working area shall be free from obstructions; before installation and operation, clear the working area. Keep the working area free from obstructions, e.g. logs, split wood, etc.
35. Do not leave the machine unattended when running;
36. Do not reach into the splitting zone;

Electrical Safety

WARNING! Always check that the power supply corresponds to the voltage on the rating plate.

WARNING! Connect the main leads to a standard 230V±10% (50Hz±1Hz) electrical supply which has protection devices of under-voltage,

over-voltage, over-current as well as a residual current device (RCD) which maximum residual current rated at 30mA.

Replacing cables or plugs

If the supply cord is damaged, it must be replaced by the manufacturer, its service agent or similarly qualified persons in order to avoid a hazard.

Immediately throw away old cables or plugs when they have been replaced by new ones. It is dangerous to insert the plug of a loose cable in the wall outlet.

Using extension cables

1. As a supply for this machine always use an unloaded line and/or extension with conductor of at least 2.5mm² and protected with a 20A fuse. Be sure that this extension cable is not longer than 10 meters. Excessively long cables or inadequate section can cause voltage drops that prevent motor from developing its full power.
2. Only connect your machine and/or extension cable to earthed electricity mains.

Grounding

In the event of an electrical short circuit, grounding reduces the risk of electric shock. Use switch socket with grounding please.

INTENDED USE

This log splitter is only intended to be used to split logs! Serious injury may occur if this log splitter is used for any other purpose.

TECHNICAL SPECIFICATIONS

Model	FFBE5TS-UK
Voltage:	230V~ 50Hz
Power consumption	1500W S3 50% (5min on/5min off)
No load Speed:	2,800min ⁻¹
Classification	Class I
Protection degree	IP 54
Max. splitting force (tons)	5 t
Diameter	30-250mm
Length	520mm
Max. Hydraulic oil capacity	3.3L
Max. hydraulic pressure	20MPa
Mass	65kg
Sound pressure level, L _{pA}	78 dB(A) k=3dB(A)
Sound power level, L _{WA}	89 dB(A) k=3dB(A)

Vibration	$\leq 2,5 \text{ m/s}^2$
Guarantee noise level	91 dB(A)

UNPACKING

WARNING! To prevent accidental starting that could cause possible serious personal injury, assemble all parts to your log splitter before connecting it to power supply. Log splitter should never be connected to power supply when you are assembling parts, making adjustment.

Carefully remove all parts from the carton and place the log splitter on a level work surface of the height not less than 60cm. Separate and check against the list of loose parts.

WARNING! If any parts are missing, do not operate this machine until the missing parts are replaced. Failure to do so could result in serious personal injury.

- Do not discard the packing materials until you have carefully inspected the log splitter, identified all parts, and satisfactorily operated your new log splitter.

Check all loose parts from the box with the list below. Assemble according to the instruction on the following pages.

- | | |
|--------------------|-------|
| 1 horizontal leg | 1pcs |
| 2 front stand | 2pcs |
| 3 back stand | 2pcs |
| 4 horizontal shaft | 2pcs |
| 5 wheel | 2pcs |
| 6 wheel shaft | 2pcs |
| 7 wheel cover | 2pcs |
| 8 circlip | 8pcs |
| 9 Bolt M8*50 | 4pcs |
| Bolt M8*45 | 6pcs |
| 10 Nut M8 | 4pcs |
| 11 Flat washer | 12pcs |
| 12 Spring washer | 4pcs |

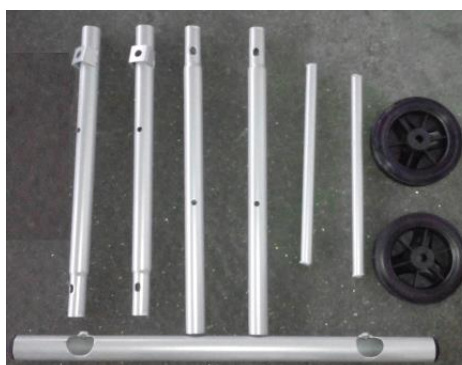

FEATURES

1. **Before attempting to use, familiarize yourself with all the operating features and safety requirements of your log splitter.**

1. Blade
2. Oil tank
3. hydraulic control lever
4. Rolling wheel
5. push button switch
6. Log pusher
7. Safety guard for hydraulic control lever
8. horizontal leg
9. horizontal shaft
10. front stand
11. wheel shaft
12. motor cover
13. back stand

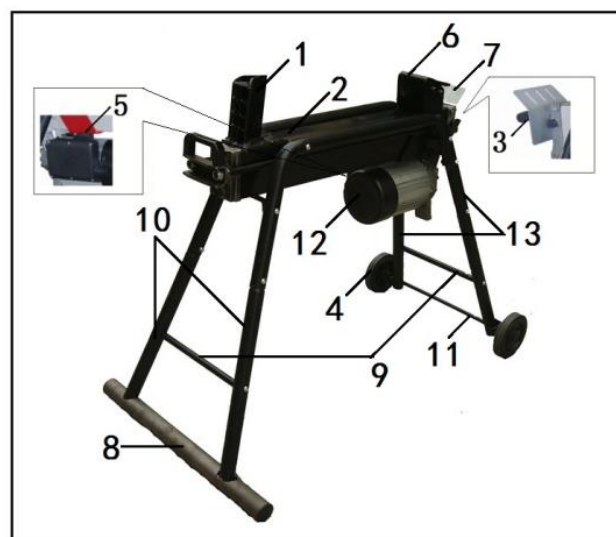

2. Size of the logs to be split

The figure 1 shows the maximum log sizes that can be split.

The diameter of the log is indicative: a small log can be difficult to split if it has knots or a particularly tough fiber. On the other hand, if the wood has regular fibers it is not difficult to split logs with diameter greater than the maximum shown in fig. 1.

It is important not to insist when the log does not split on the first attempt, as the pump may be damaged by the overheating of the oil when the machine is made to work under the maximum stress in the attempt to split excessively hard wood.

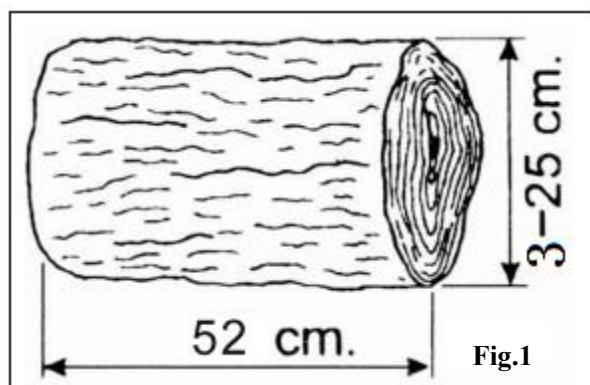

3. Recommended oils

We recommend use of the following oils for the hydraulic cylinder.

SHELL TELLUS T22

ARAL VITAM GF22

SP ENERGOL HCP22

MOBILE DTE 11 OR equivalent

DO NOT USE OTHER GRADE OILS

4. Application conditions

This log splitter is a home use model. It is designed for operating under ambient temperature between $+5^{\circ}\text{C}$ and 40°C and use at altitudes no more than 1000mm. The surrounding humidity should less than 50% at 40°C . It can be stored or transported under ambient temperatures between -25°C and 55°C .

ASSEMBLY

Warning! For your own safety, do not connect the log splitter to the power source until the machine is completely assembled and you read and understand the entire instruction manual.

Warning! For your own safety, never forget to bolt the support legs to the log splitter, place the log splitter on flat and level ground.

Warning! Never use the log splitter if it is not in perfect order or if it needs servicing. Before starting work, check correct functioning of all the safety devices (ZHB, push button).

a) Connect front stand (10a) to connection pipe (a) and front stand (10b) to connection pipe (b) by bolts and nuts (fig.2).

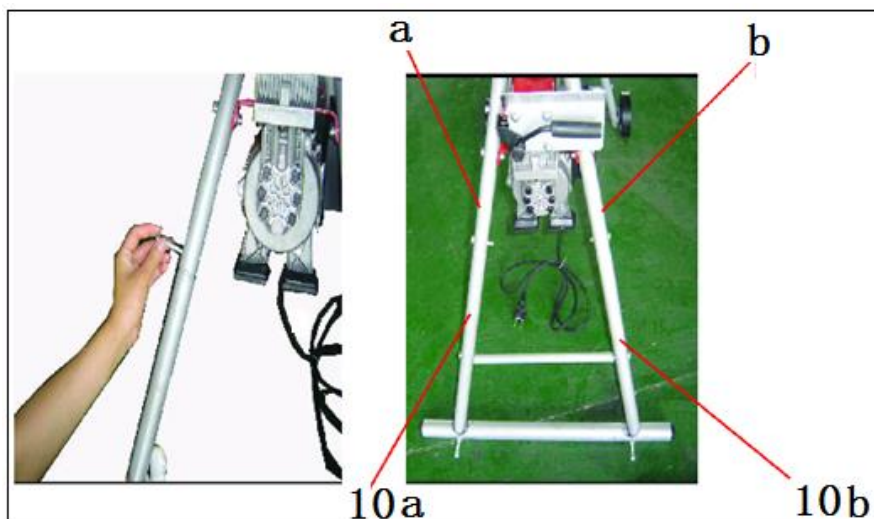

fig.2

- b) Connect horizontal shaft (9a) to front stand(10a&10b) with screws, then assemble horizontal leg(8) and fix it to front stand(10a&10b) by bolts (fig.3).

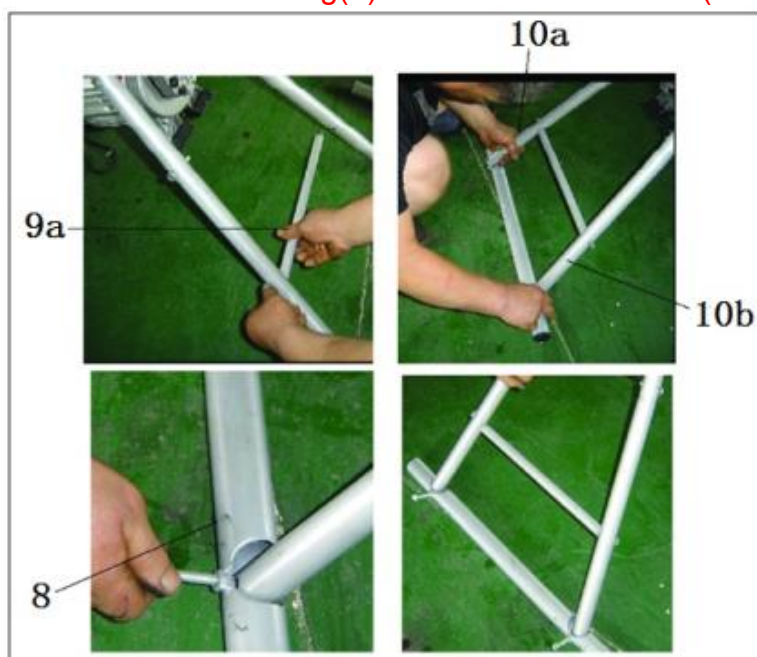

fig.3

- c) Connect back stand (13c) to connection pipe (c) and connect back stand (13d) to connection pipe (d) by bolts and nuts (fig.4).

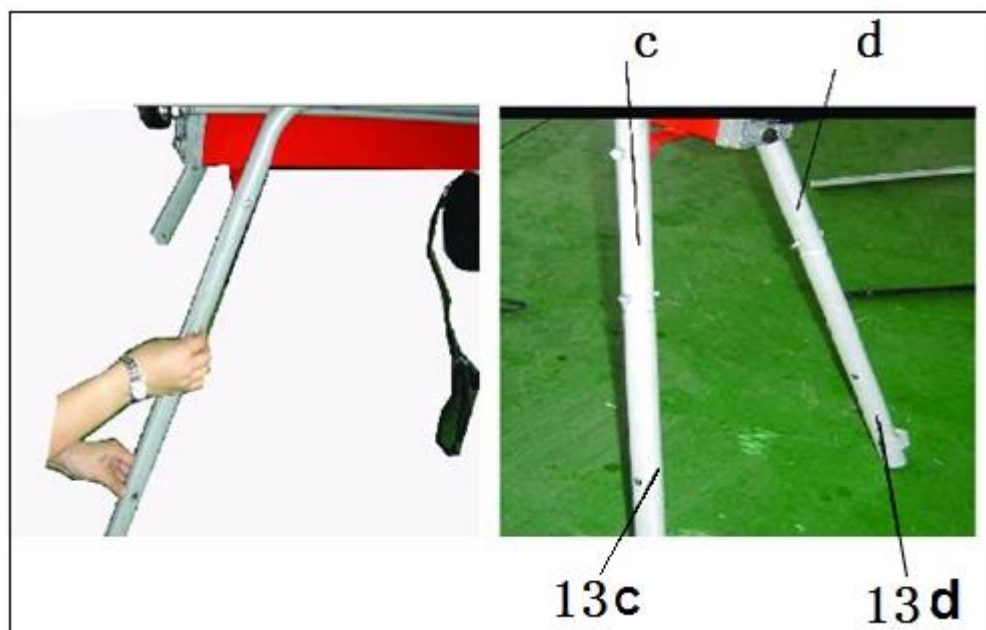

fig.4

d) Connect horizontal shaft (9b) to back stand (13c&13d) with bolts, assemble the wheel shaft (11) and wheels with four spring washers, the last fit wheel covers (fig.5).

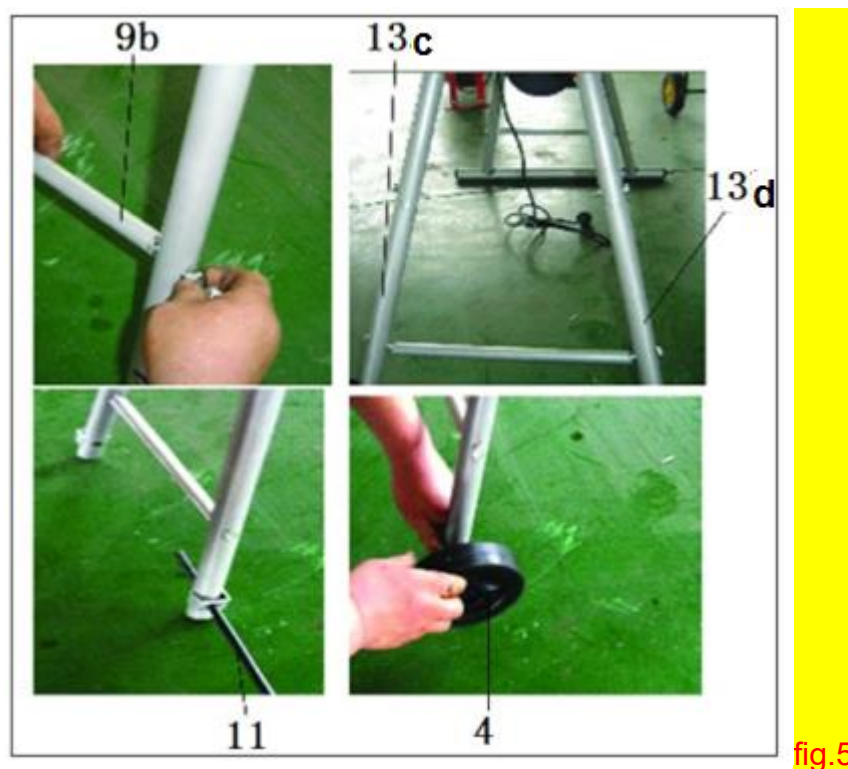

fig.5

Remove the accessories as shown in the figure from the carton and check the number of accessories, and then install according to the following steps:

1. Using the Allen wrench to make the two M8×16 screws through the two washer8 and the mounting hole for left side support plate, then tighten the screw holes corresponding to the bent legs(fig. 1)

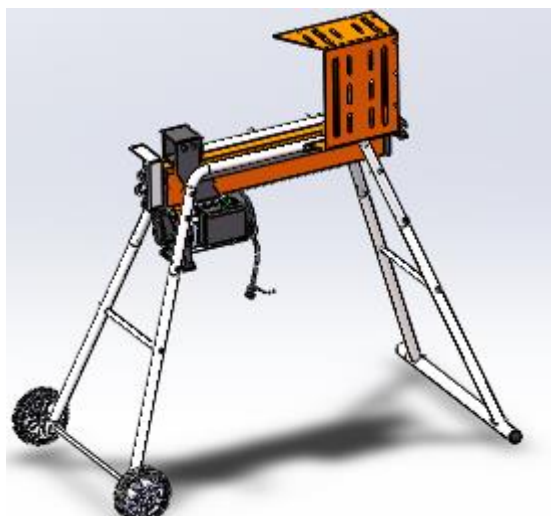

Fig.1

2、 Push the three M8×16 screws through the three washer8 and the mounting hole, then tighten the screw holes corresponding to the bent legs. Push the four M8×16 bolts through the mounting hole of the connecting plate and the support plate, then tighten with four M8 nuts. (Fig.2)



Fig.2

3、 Connect the back cover, protection guard and support plate with M8×16 bolt and M8 nut. (Fig. 3)

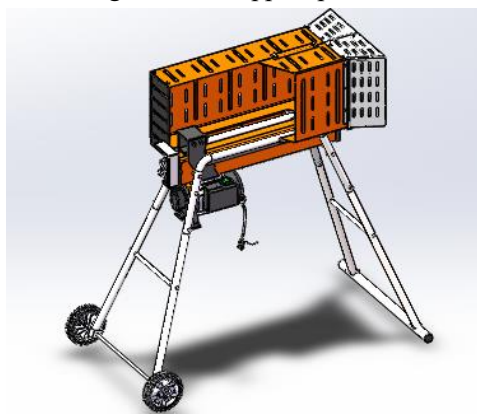

Fig. 3

4、 Install the stock support plate. Push the two M8×16 screws through mounting hole of the support plate and the stock support plate, tighten with two M8 nuts. Then push two M8×16 screws through the two mounting hole of the stock support plate, push two M8×50 bolts through the mounting hole of the left and right bent legs and mounting hole of the stock support plate on the other side, tighten with four M8 nuts. (Fig. 4)

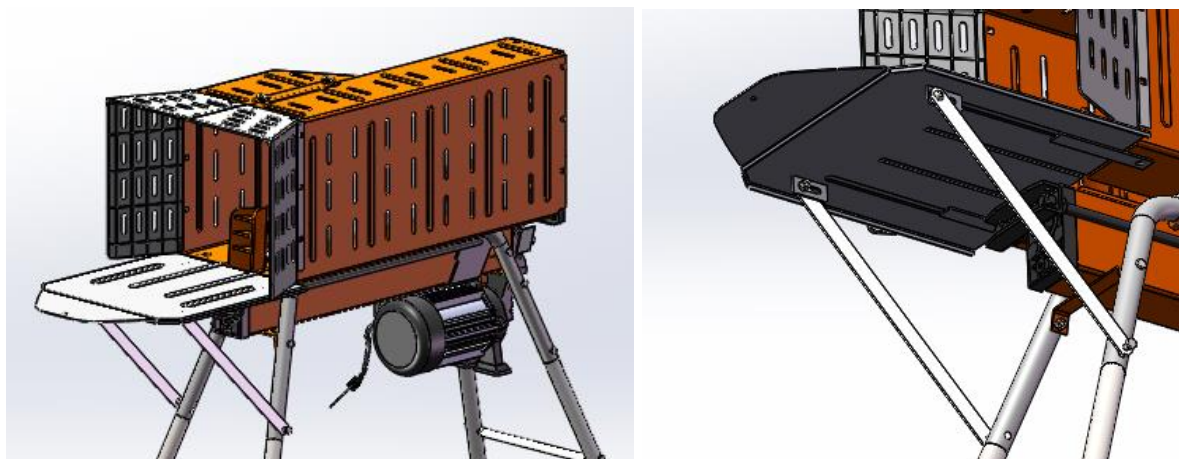

Fig. 4

5、 After the third step, an entire machine has been assembled

OPERATION

Warning!

Before operating the log splitter, the Bleed Screw (15) Fig. 6, should be loosened by some rotations until air can go in and out of the oil tank smoothly.

Air flow through the Bleed Screw hole should be detectable while the log splitter is under operations.

Before moving the log splitter, make sure the Bleed Screw is tightened to avoid oil leaking from this point.

Failed to loosen the bleed screw will keep the sealed air in hydraulic system being compressed after being decompressed, such continuous air compression and decompression will blow out the seals of the hydraulic system and cause permanent damage to the log splitter.

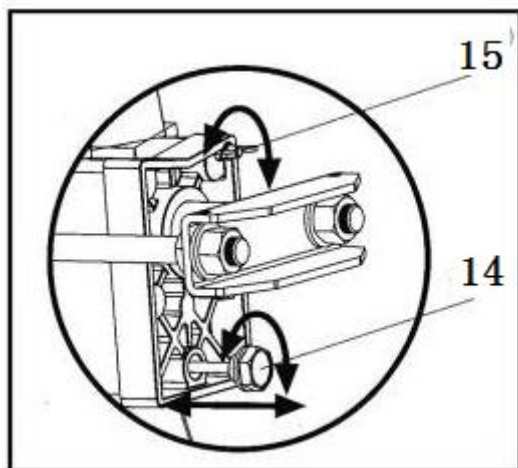

Fig.6

DO NOT ADJUST THE MAX PRESSURE

LIMITING SCREW (16) IN FIG. 7!

Max pressure was set before the log splitter ex work and the max pressure limiting screw is tightened to ensure the log splitter works under pressure no more than 6 tons. The setting was done by qualified mechanic with professional instruments.

Unauthorized resetting will cause the hydraulic pump fail to output enough splitting pressure or **RESULT IN SERIOUS INJURY AS WELL AS DAMAGE TO THE MACHINE.**

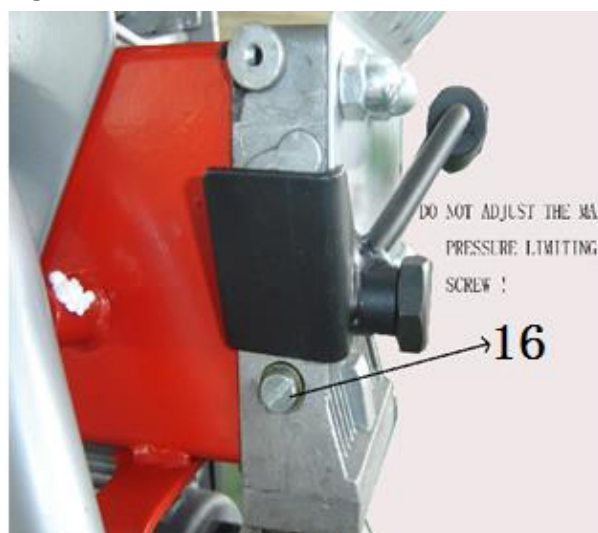

Fig. 7

Make sure that the screws are tightened up properly before operation the log splitter!

This log splitter is equipped with control system that requires to be operated by both hands of the user – left hand controls the hydraulic control lever (3) while right hand controls the push button switch (5) as shown in Fig. 8. The log splitter

will freeze upon absence of either hand. Only after both hands release the controls, the log pusher starts to return backward to the starting position.

Never force the log splitter for more than 5 seconds by keeping pressure on it to split excessively hard wood.

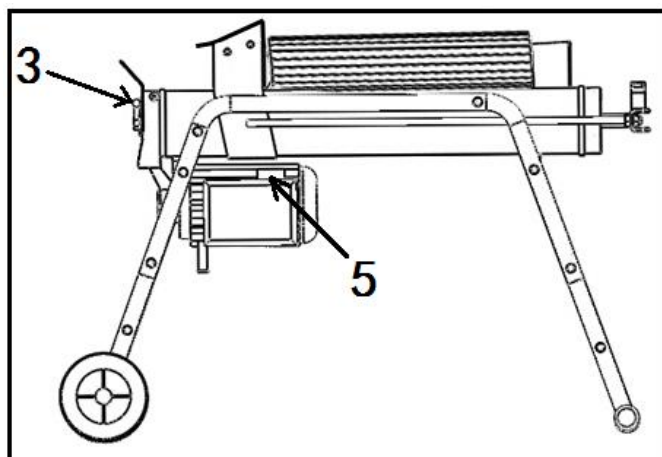

Fig .8

After this time interval, the oil under pressure will be overheated and the machine could be damaged. For such extremely hard log, rotate it by 90° to see whether it can be split in a different direction. In any case, if you are not able to split the log, this means that its hardness exceeds the capacity of the machine and thus that log should be discarded to protect the log splitter.

NOTE: During operation, the metal part connected to the motor remains cold or in any case reaches a temperature only slightly higher than the ambient temperature. After several hours of use with particularly difficult wood, the pump may become very hot. This is not a dangerous situation for the machine, which returns to full functioning capacity after being cooled. On the other hand, it is very important not to cause overheating of the oil, and thus the pump, by forcing the machine in an attempt to split logs that exceed the capacity of the machine.

Always set logs firmly on the log retaining plates and work table. Make sure logs will not twist, rock or slip while being split. Do not force the blade by splitting the log on the upper part. This will break the blade or damage the machine. (Fig.9)

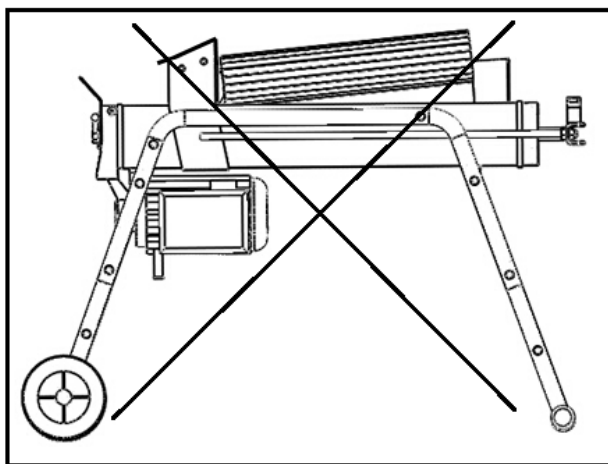

Fig. 9

Break log in the direction of its grown grain. Do not place log across the log splitter for splitting. This may be dangerous and may seriously damage the machine. Do not attempt to split 2 pieces of logs at the same time. One of them may fly up and hit you.

Freeing a jammed log (fig.10)

1. Release both controls.
2. After the log pusher moves back and completely stops at its starting position, insert a wedge wood under the jammed log.
3. Start the log splitter to push the wedge wood to go completely under the jammed one.
4. Repeat above procedure with sharper slope wedge woods until the log is completely free.

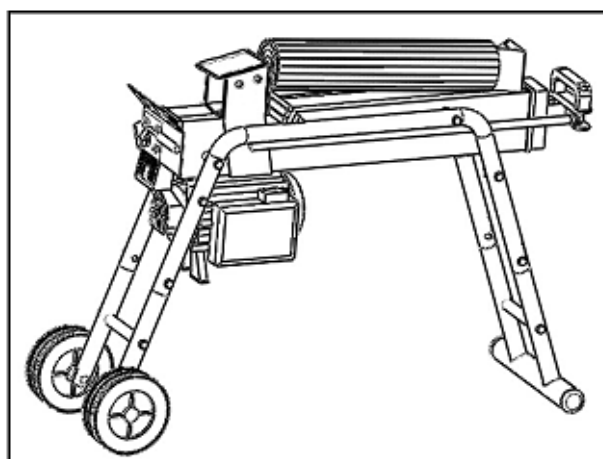

Fig.10

Do not try to knock the jammed log off. Knocking will damaged the machine or may launch the log and cause accident (fig.11).

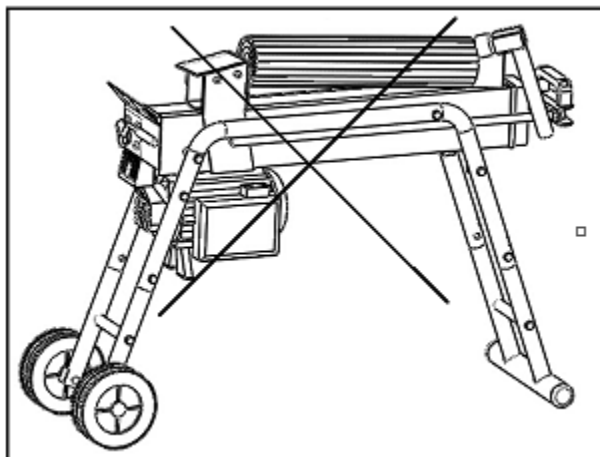

Fig.11

MAINTENANCE

Replacing hydraulic oil (fig.12)

Replace the hydraulic oil in the log splitter after every 150 hours of use. Take following steps to replace it.

1. Make sure all moving parts stops and the log splitter is unplugged.
2. Unscrew oil drain bolt (14) (fig.6) with dipstick to remove it.
3. Turn the log splitter **on the support leg side** over a 3.3 liter capacity container to drain the hydraulic oil off.
4. **Turn the log splitter on the motor side.**
5. Refill fresh hydraulic oil at the volume as per the hydraulic oil capacity of a particular model indicated in the specifications table.
6. **Clean the surface of Dipstick on the oil drain bolt and put it back into the oil tank while keep the log splitter vertically.**
7. Make sure the level of the refilled oil is just between 2 grooves around the dipstick.
8. Clean the oil drain bolt before thread them back. Make sure they are tightened to avoid leakage before placing the log splitter horizontally.

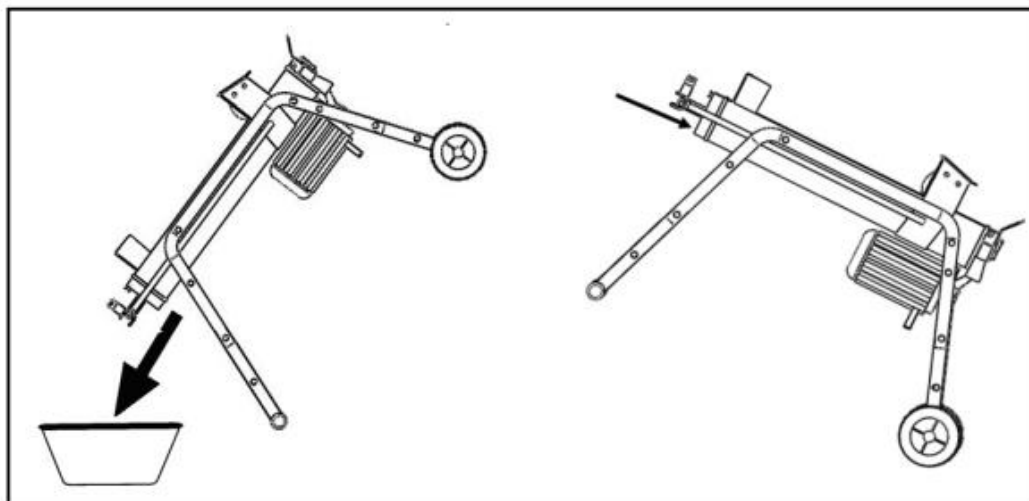

fig.12

Periodically check oil level to ensure it is between 2 grooves around the dipstick. Upon lower oil level, oil refilling is required.

Warning: Never mix oil with general waste!

Used oil must be disposed of according to current regulations in the country where the machine is used.

Sharpening the wedge

After using the log splitter for some time, sharpen the wedge of the log splitter using a fine-toothed file and smooth any burrs or crushed area along the cutting edge

STORAGE

When you have finish working with your log splitter:

1. Disconnect the log splitter from the mains supply.
2. **Tighten** the oil yank cover / air bleeder,
3. Clean the unit down **using** a dry cloth.
4. Store in a dry and well-ventilated area.

TROUBLESHOOTING

PROBLEM	PROBABLE CAUSE	REMEDY SUGGESTED
Motor stops starting	Overload protection device disengaged to protect the log splitter from being damaged	Let motor cool down, and push the button of the overload protection device to re-start the motor
Fails to split logs	Log is improperly positioned	Refer to "Log splitter operation" section for perfect log loading
	The sizes or hardness of the log exceeds the capacity of the machine	Reduce the log size before splitting it on the log splitter
	Wedge cutting edge is blunt	Refer to "Sharpening wedge" section to sharpen the cutting edge.
	Oil leaks	Locate leak(s) and contact the dealer
	Unauthorized adjustment was made on Max. Pressure Limiting Screw. Lower max pressure rating was set.	Contact the dealer

The log pusher moves jerkily, taking unfamiliar noise or vibrating a lot	Lack of hydraulic oil and excessive air in the hydraulic system	Check oil level for possible oil refilling. Contact the dealer.
Oil leaks around cylinder ram or from other points	Air sealed in hydraulic system while operating	Loosen bleed screw by some rotations before operating the log splitter
	Bleed screw is not tightened before moving the log splitter	Tight the bleed screw up before moving the log splitter
	Oil drain bolt with dipstick is not tight.	Tighten the oil drain bolt with dipstick
	Hydraulic control valve assembly and/or seal(s) worn.	Contact the dealer

DISPOSAL



Do not dispose of power tools into household waste! According the European Guideline [2012/19/EU](#) for Waste Electrical and Electronic Equipment and its implementation into national right, power tools that are no longer usable must be collected separately and disposed of in an environmentally correct manner.

Never dispose the residual fluids into household waste too. It must be collected separately and disposed of in an environmentally correct manner too.

Declaration  of conformity

BUILDER SAS

**ZI, 32, rue Aristide Bergès – 31270 Cugnaux - France
Tel : +33 (0)5.34.502.502 Fax : +33 (0)5.34.502.503**

Declare that this machine:

ELECTRIC LOGSPLITTER

Model: FFBE5TS-UK

Is in conformity with the Directive 2006/42/EC and the regulations transposing it;

Also in conformity with the following Directives:

RoHS Directive 2011/65/UE

EMC Directive 2014/30/UE

Also in conformity with the following standards:

EN609-1:2017

EN60204-1:2006+A1:2009

EN55014-1:2017

EN55014-2:2015

EN61000-3-2:2014

EN61000-3-11:2000

Responsible of technical file: Olivier Patriarca

Cugnaux, le 17/06/2019



Philippe MARIE / PDG