



**INSTRUCTION MANUAL**

**ELECTRIC BLOWER VACUUM SHREDDER**

**FASBE1600 / FASBE1600-UK**



**BUILDER SAS**

**32 Rue Aristide Bergès, 31270 CUGNAUX - FRANCE**



Please read the instructions carefully before starting the machine.

## **CONTENTS**

1. Safety instructions
2. Assembly
3. Starting up the machine
4. Operation
5. Maintenance
6. Technical Data
7. Declaration of Conformity
8. Warranty
9. PRODUCT FAILURE
10. WARRANTY EXCLUSIONS

# 1. Safety instructions

## **IMPORTANT**

**READ CAREFULLY BEFORE USE**

**KEEP FOR FUTURE REFERENCE**

**Safe operating practices for hand-held mains-operated electrical garden vacuums, and garden blower/vacuums with or without shredding means and garden blowers**

### **Training**

- a) Read the instructions carefully. Be familiar with the controls and the correct use of the machine.
- b) Never allow children or people unfamiliar with these instructions to use the machine.
- c) Local regulations can restrict the age of the operator.
- d) Keep in mind, that the operator or user is responsible for accidents or hazards occurring to other people or their property.

### **Preparation**

- a) Obtain ear protection and safety glasses. Wear them at all times while operating the machine.
- b) While operating the machine always wear substantial footwear and long trousers. Do not operate the machine when barefoot or wearing open sandals. Avoid wearing clothing that is loose fitting or that has hanging cords or ties.

- c) Do not wear loose clothing or jewellery that can be drawn into the air inlet. Keep long hair away from the air inlets.
- d) Operate the machine in a recommended position and only on a firm, level surface.
- e) Do not operate the machine on a paved or gravel surface where ejected material could cause injury.
- f) Before using, always visually inspect to see, that the **shredding means, shredding means** bolts and other fasteners are secure, the housing is undamaged and that **guards** and screens are in place. Replace worn or damaged components in sets to preserve balance. Replace damaged or unreadable labels.
- g) Before use, check the supply and extension cord for signs of damage or aging. If the cord becomes damaged during use, disconnect the cord from the supply immediately. **DO NOT TOUCH THE CORD BEFORE DISCONNECTING THE SUPPLY.** Do not use the machine if the cord is damaged or worn.
- h) Never operate the machine while people, especially children, or pets are nearby.

## **Operation**

- a) Before starting the machine, make certain that the feeding chamber is empty.
- b) Keep your face and body away from the feed intake opening.

- c) Do not allow hands or any other part of the body or clothing inside the feeding chamber, discharge chute, or near any moving part.
- d) Keep proper balance and footing at all times. Do not overreach. Never stand at a higher level than the base of the machine when feeding material into it.
- e) Always stand clear of the discharge zone when operating this machine.
- f) When feeding material into the machine be extremely careful that pieces of metal, rocks, bottles, cans or other foreign objects are not included.
- g) If the cutting mechanism strikes any foreign objects or if the machine should start making any unusual noise or vibration, immediately shut off the power source and allow the machine to stop. Disconnect the machine from the supply and take the following steps before restarting and operating the machine:
  - i) inspect for damage;
  - ii) replace or repair any damaged parts;
  - iii) check for and tighten any loose parts.
- h) Do not allow processed material to build up in the discharge zone; this may prevent proper discharge and can result in kickback of material through the intake opening.
- i) If the machine becomes clogged, shut-off the power source and disconnect the machine from supply before

cleaning **debris**.

j) Never operate the machine with defective **guards** or shields, or without safety devices, for example **debris collector** in place.

k) Keep the power source clean of debris and other accumulations to prevent damage to the power source or possible fire.

l) Do not transport this machine while the power source is running.

m) Stop the machine, and remove plug from the socket. Make sure that all moving parts have come to a complete stop

- whenever you leave the machine,
- before clearing blockages or unclogging chute,
- before checking, cleaning or working on the machine.

n) Do not tilt the machine while the power source is running.

## **Maintenance and storage**

a) When the machine is stopped for servicing, inspection, or storage, or to change an accessory, shut off the power source, disconnect the machine from the supply and make sure that all moving parts are come to a complete stop. Allow the machine to cool before making any inspections, adjustments, etc. Maintain the machine with care and keep it clean.

- b) Store the machine in a dry place out of the reach of children.
- c) Always allow the machine to cool before storing.
- d) When servicing the **shredding means** be aware that, even though the power source is switched off due to the interlock feature of the **guard**, the **shredding means** can still be moved.
- e) Replace worn or damaged parts for safety. Use only genuine replacement parts and accessories.
- f) Never attempt to override the interlocked feature of the **guard**.

### **Additional safety instructions for units with bagging attachments**

Switch-off the machine before attaching or removing the bag.

### **Recommendation**

The machine should be supplied via a residual current device (RCD) with a tripping current of not more than 30 mA.

### **Additional instructions**

- This appliance is not intended for use by persons (including children) with reduced physical, sensory or mental capabilities, or lack of experience and knowledge, unless they have been given supervision or instruction concerning use of the appliance by a person responsible for their safety. Children should be supervised to ensure

that they do not play with the appliance.

- Do not allow children, people with reduced physical, sensory or mental abilities, or those with no experience and knowledge or people who do not know these instructions to use the machine. Local regulations may restrict the age of the operator.
- Do not use the machine when people, especially children, or pets are nearby.
- Remember that the operator or user is responsible for accidents or hazards that occur to people or their property
- Before connecting the machine, check:

If the tool and cable are not damaged. If anything is damaged, do not use the machine and return it to your dealer for inspection and repair.

The voltage marked on the nameplate of the tool corresponds to that of your electrical installation.

- Do not use accessories other than those recommended by the manufacturer; Accessories not recommended may damage the unit and / or cause injury.
- Do not disassemble the tool yourself. Any disassembly, repair or inspection must be performed by qualified personnel only.
- Use the tool fully assembled and secure. Before use, check that the guards and safety devices are in place.



- When operating the machine, always wear protective equipment including: face shield, visor or goggles, ear protection, helmet, gloves, non-slip shoes and protective clothing.
- Always carry the machine by its handle; Never use the cord or any other part of the machine.
- Do not use the machine when you are tired, under the influence of alcohol, drugs or when you are sick.
- Use the tool to vacuum and blow leaves and similar materials. Do not blow flammable materials, cigarette butts and materials that may damage the unit.
- Do not use the appliance to suck up water or wet debris.
- Always use the machine with the collection bag.
- Avoid using the machine in bad weather, especially when there is a risk of thunderstorms and lightning.
- In the event of an accident, stop using the machine immediately. Turn it off and unplug it to check the problem. Do not use the machine when it is damaged.
- Do not use the tool in an area where there is insufficient ventilation. Gas emissions can cause injury.
- Do not use the tool in humid places.
- Do not use the tool in the presence of flammable liquids or gases.
- Do not use the product with damaged guards or shields, shields or screens not in place.

- Do not bend. Keep a good balance at all times.
- Keep handles dry, clean and free of oil and grease.
- Use and handle the machine with care
- Do not put your body, clothing or shoes near the air opening.
- Do not lift the tool while it is running.
- Do not point the tool in front of people; this can lead to accidents and injuries.
- Do not place any objects inside the tube and inside the tool.
- Before using the machine and after a shock, check for signs of wear or damage. Please make repairs if necessary.
- Inspect and maintain the product regularly. Repairs should only be performed by an authorized service center or qualified specialist.
- Children should not play with plastic bags, sheets and small parts! Keep them out of the reach of children. There is a risk of suffocation!
- Do not use the product on a slippery surface.
- Do not use the product on steep, slippery slopes. If you need to work on the slopes, use extreme care and pay attention to your feet. Please wear non-slippery shoes.
- When planning your work schedule, allow enough

time for rest. Limit continuous use of the device, for example, use 30 to 40 minutes per session and take 10 to 20 minutes of rest between work sessions. Work a maximum of two hours a day.

- Do not connect a damaged cable or touch a damaged cable before it is disconnected from the power supply; Damaged cables may cause contact with live parts.
- Keep extension cords away from hazardous moving parts to prevent damage to cords that may cause contact with live parts.
- When a cable is damaged or entangled, stop using the tool immediately. Turn off the tool, let it cool down and unplug it securely.
- Do not overreach and keep the balance at all times; always be sure of the footing on slopes. Walk, never run.
- Do not touch moving hazardous parts before the machine is disconnected from the mains and the moving hazardous parts have come to a complete stop.
- The extension cable shall not be lighter than the standardized code H05 RN-F/H05 VV-F. See your retailer or manufacturer for more advice.
- If the supply cord is damaged, it must be replaced by the manufacturer, its service agent or similarly qualified persons in order to avoid a hazard.

## **Residual risks**

Even if you use this product in accordance with all safety requirements, the risk of injury and damage remain. The following hazards may occur in the structure and design of this product:





- a. There is adverse health consequences resulting from the emission of vibrations if the product is used for long periods or if it is not properly handled and properly maintained.
- b. Risk of injury to persons and property caused by projectiles.
- c. Prolonged use of this product may expose the operator to vibration and may produce a so-called "white finger" disease. To reduce the risk, wear gloves and keep your hands warm.
- d. If any of the symptoms of "white finger syndrome" occur, seek medical attention immediately. "White finger" symptoms include numbness, loss of sensitivity, tingling, tingling, and pain, loss of strength, colour changes, or skin condition. These symptoms usually appear on the fingers, hands or wrists. The risk increases at low temperature.
- e. Inhalation of particles of blown / aspirated material
- f. Involuntary projections
- g. Contact with foreign bodies
- h. Contact with the tool in operation











## **Intended use**

This vacuum / blower is intended to be used for the suction and blowing of leaves, dust and similar small materials. It should not be used to vacuum and blow water, chemicals, flammable materials, metal or wood and other dangerous objects.

- This product is intended for private household use only. It should be used outdoors.
- This product is not intended for use in a closed room or in places where gases and flames may be present.
- Use of this product in rain or humidity is prohibited.
- Do not use this machine as described in this manual and only for the intended use as described above.
- Any other use may cause damage to the device, property damage or personal injury.
- No liability will be accepted for damage resulting from improper use or non-compliance with this manual.

Warning symbols explanation:

	WARNING/ Caution!
	Read the operating instructions to reduce the risk of injury.
	Risk of projections
	Risk of injury by rotating impeller.

	Keep your hands in safe distance.
	Keep away from the danger area.
	Wear eye protective goggles! Wear ear protectors!
	Unplug the mains plug if the cable becomes damaged or tangled.
	Always disconnect the machine from the mains before commencing maintenance. Read the instructions
	Keep dry at all times. Never expose tool to rain.
	CE marking
	Any damaged or disposed electric or electronic devices must be delivered to appropriate collection centers.
	Class II tool.
	Guarantee sound power level

## 2. Assembly

2.1. Take out the machine from the packing case, check below parts are available or not, if some parts are missing, please contact your agent in time.

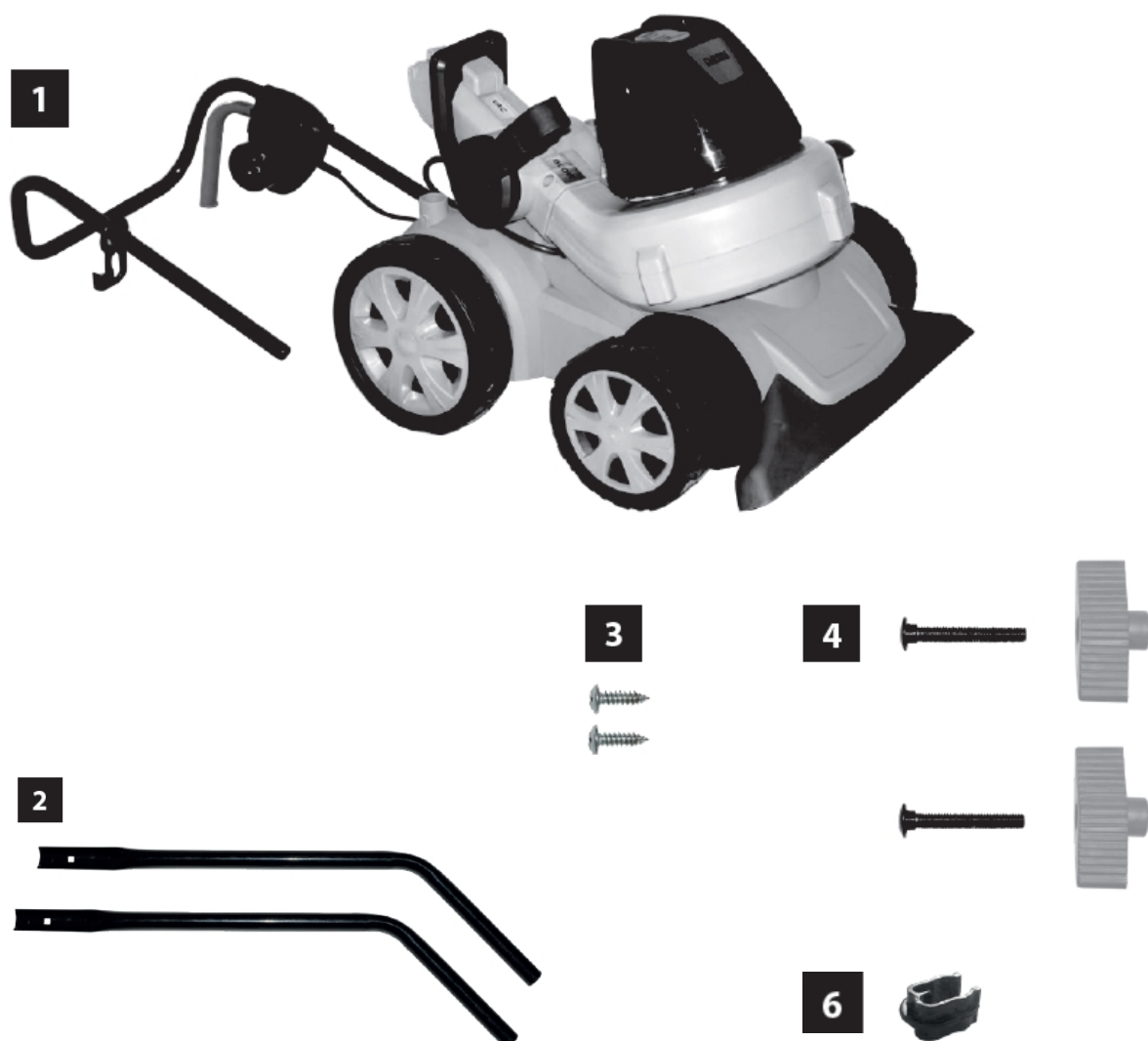

1. UPPER BAR
2. LOWER BAR
3. BOLTS
4. Square neck bolts & with two-Angle button
5. Collection bag
6. CLIP

2.2. Insert the lower bar (2) into the holes of deck and lock with the blots(3).

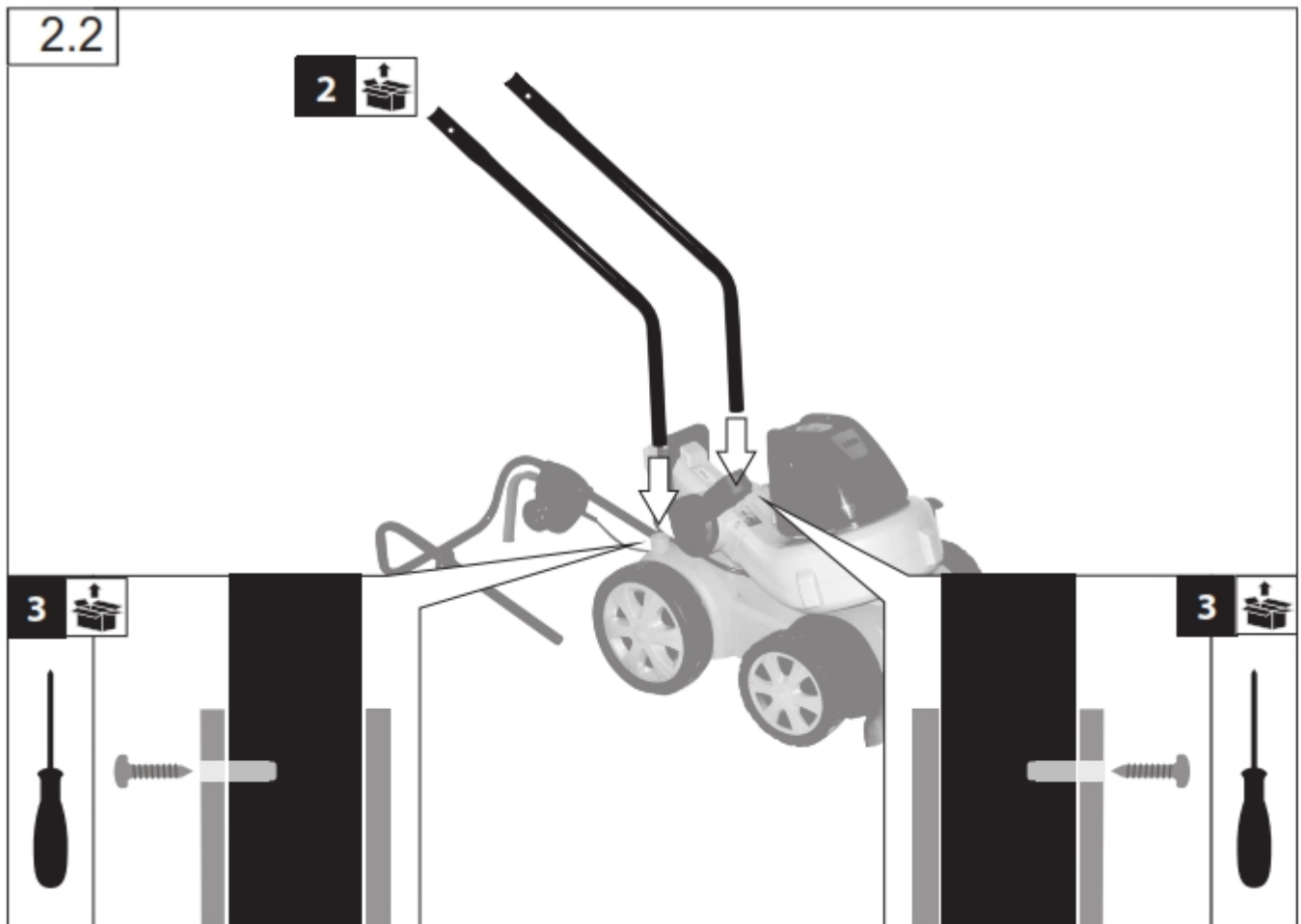

2.3. Connect and lock the upper bar and lower bar with square neck bolts & with two-Angle button(4).

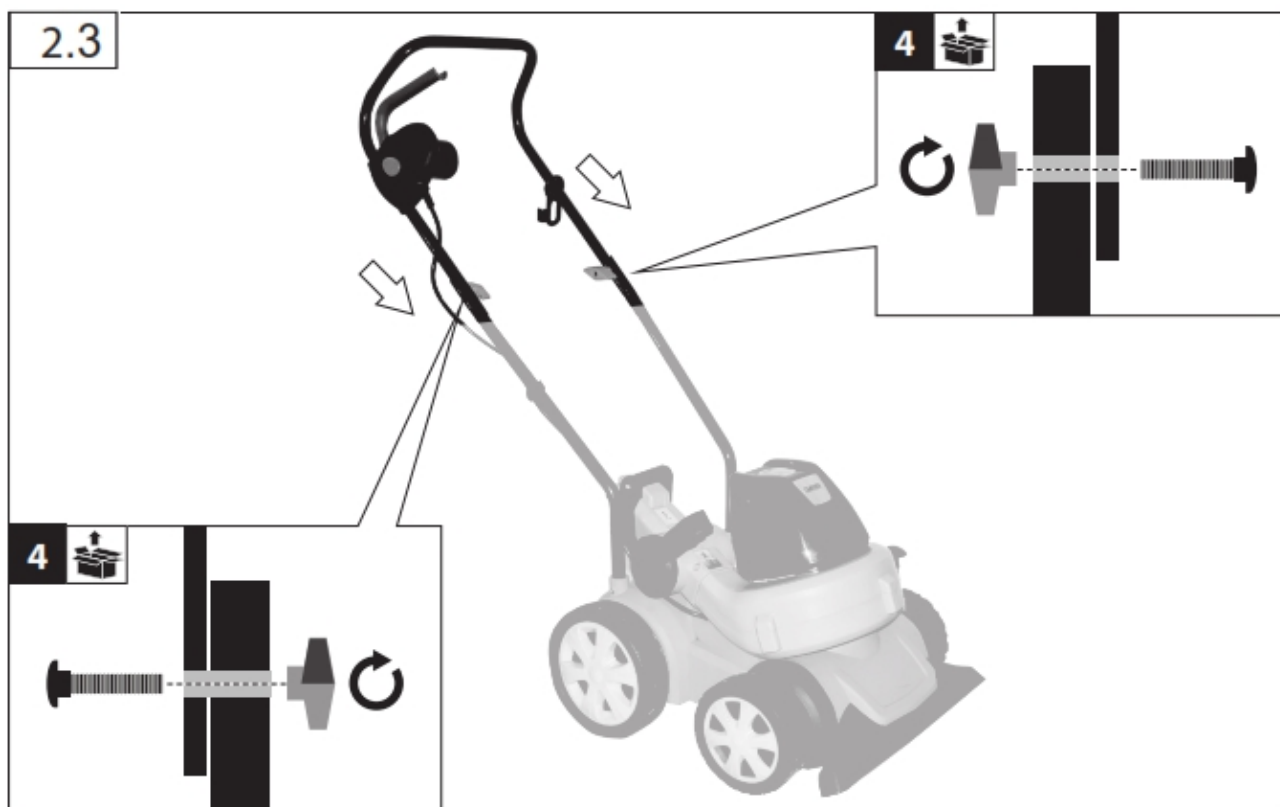



2.4 Clamp the wire with clip on the bar.

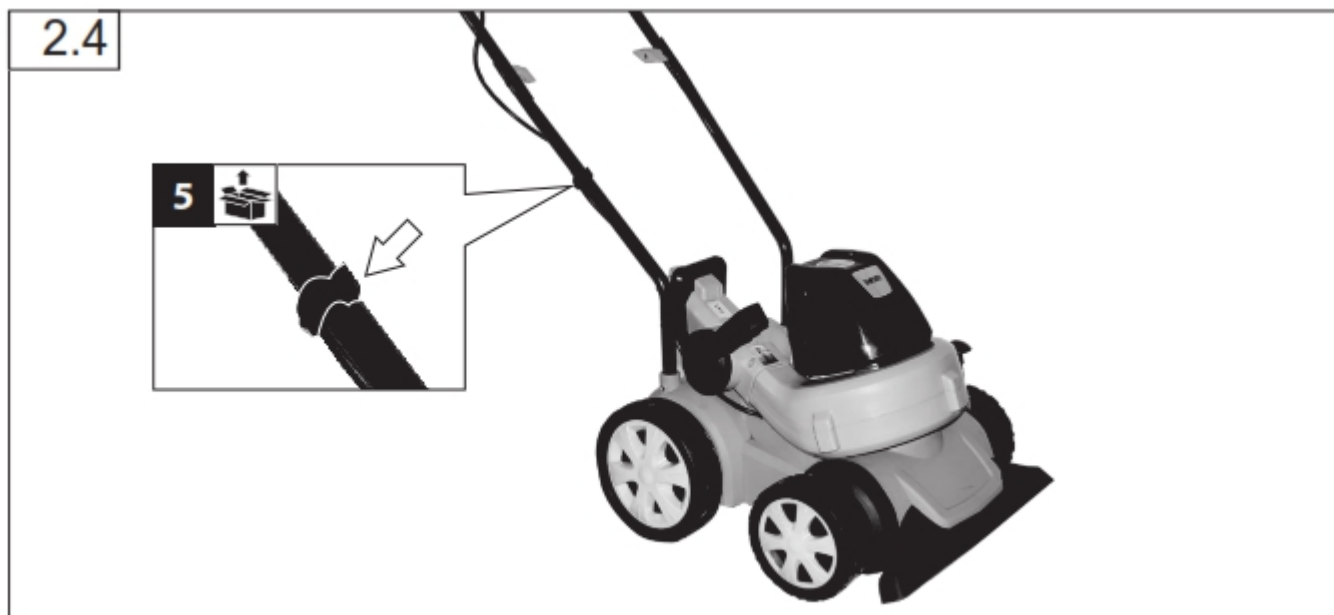

2.5 Install the collection bag(5): Plastics part on collection bag locked with machine, 4 hooks on the collection bag are hung on the bar.

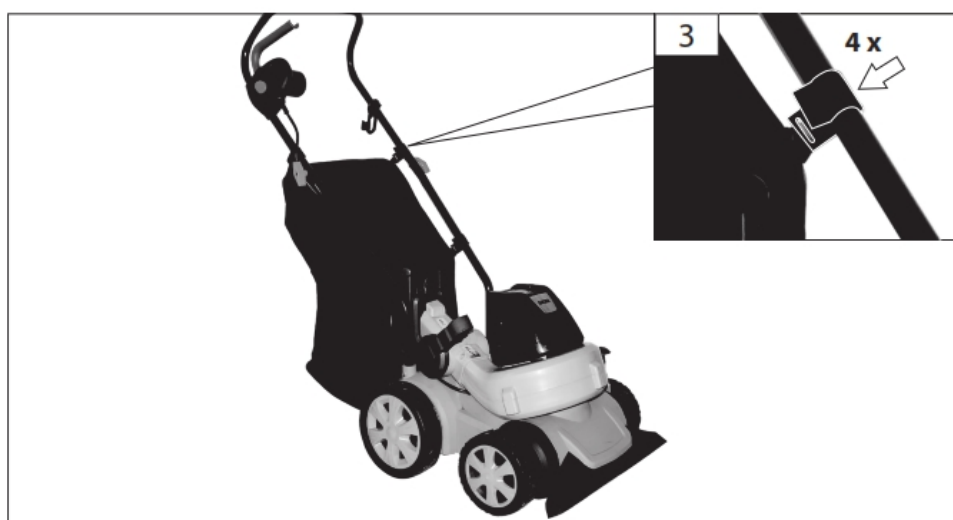
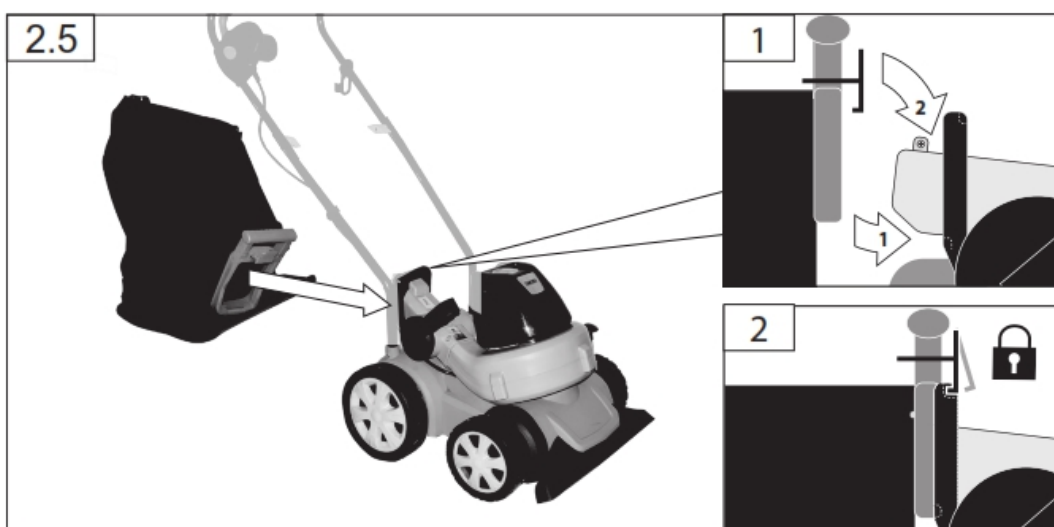

### 3 Starting up the machine

3.1 Adjust the working height of the machine, 4 position.

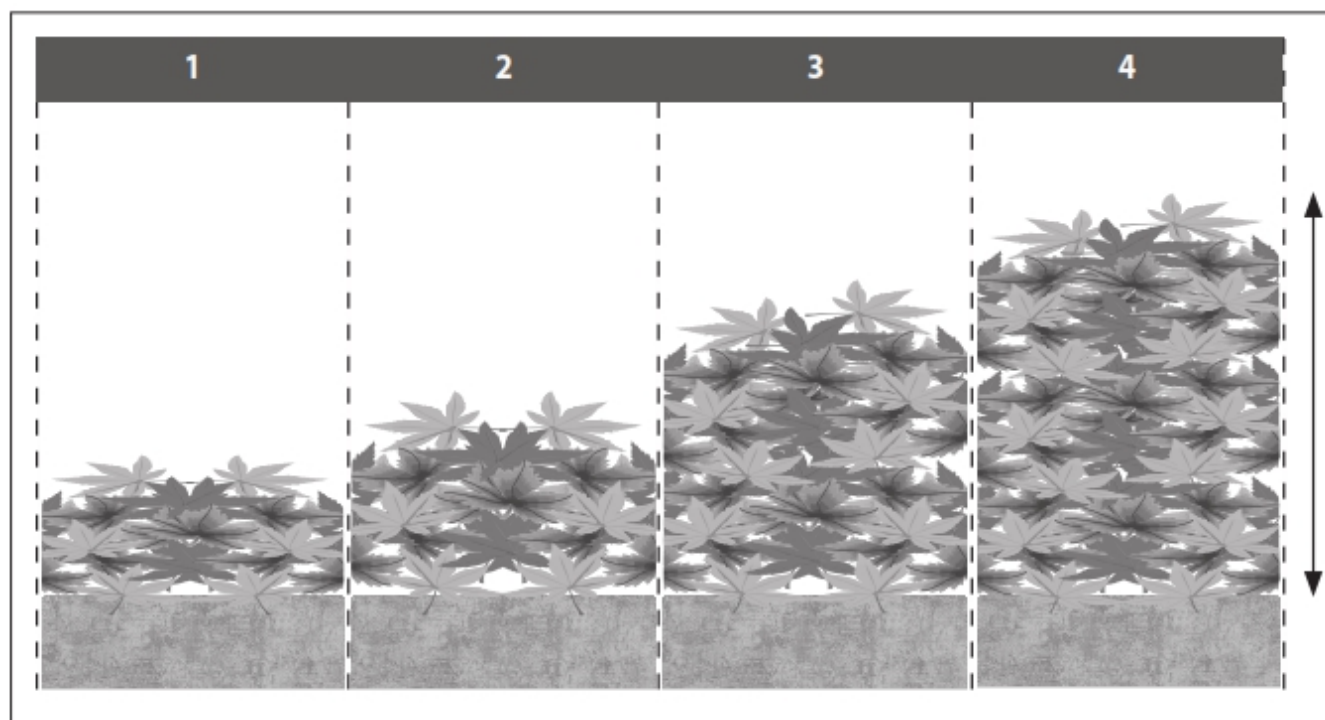
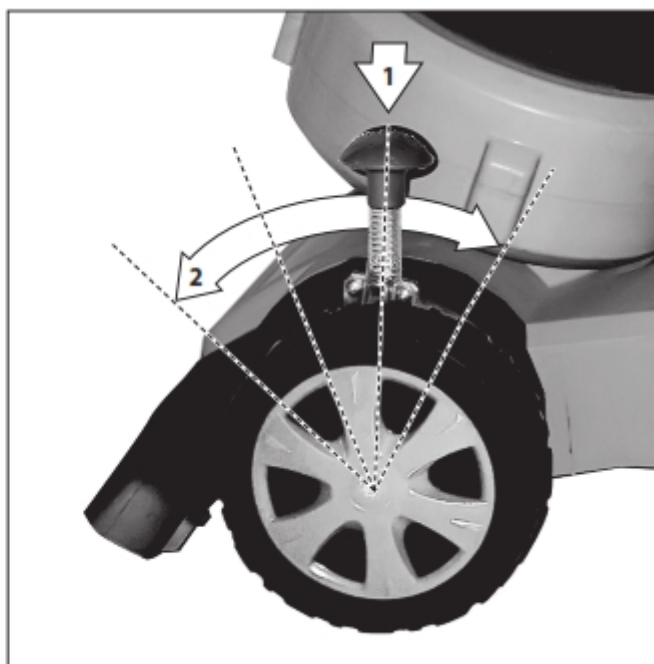

### 3.2 Start the machine

- 1) Connect the power cord to the switch box of the machine;
- 2) Press the button on the switch box, Then press the trigger and the machine starts.
- 3) Release the trigger then the machine stopped.



**S T A R T**



**S T O P**



## 4. Operation

### 4.1 Vacuum function:

- 1) Put the adjustor on the left position
- 2) Collection bag capacity 45L, take off the collection bag from machine to clean the leaves in time.

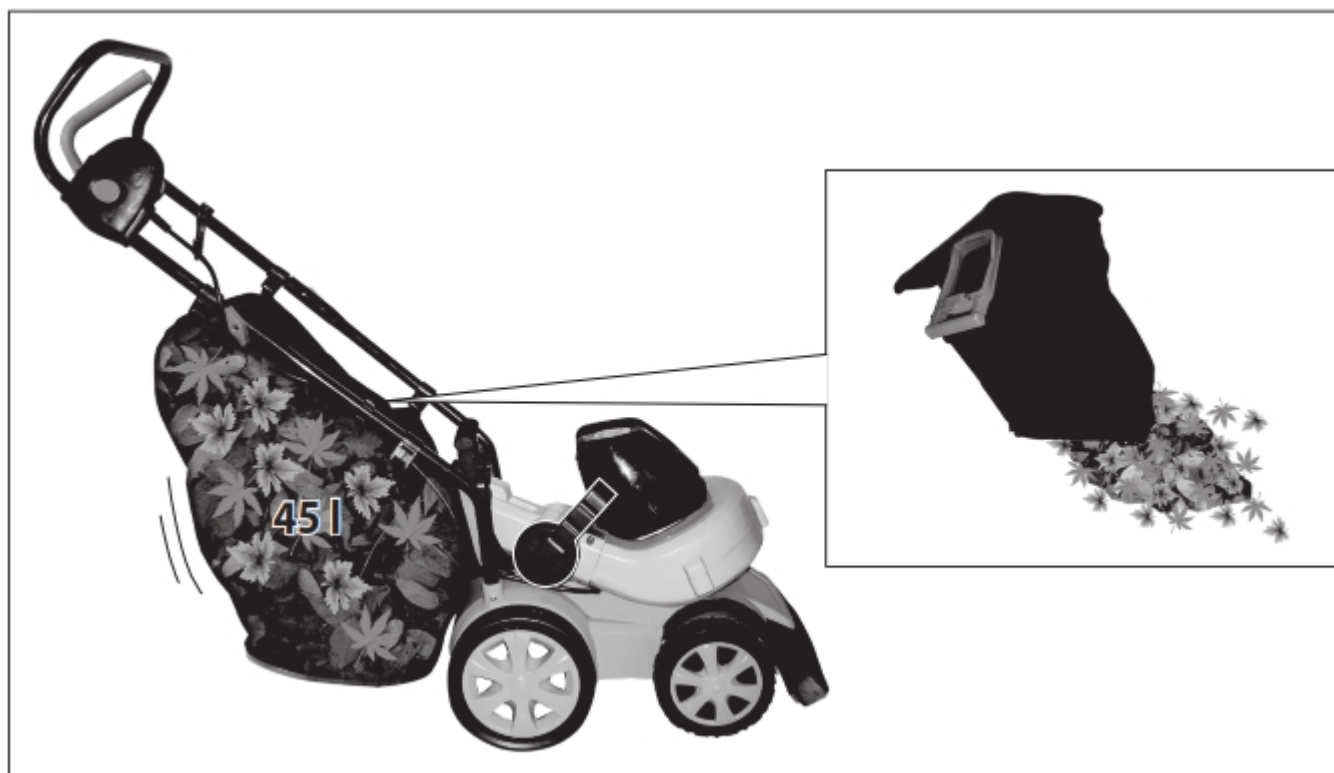
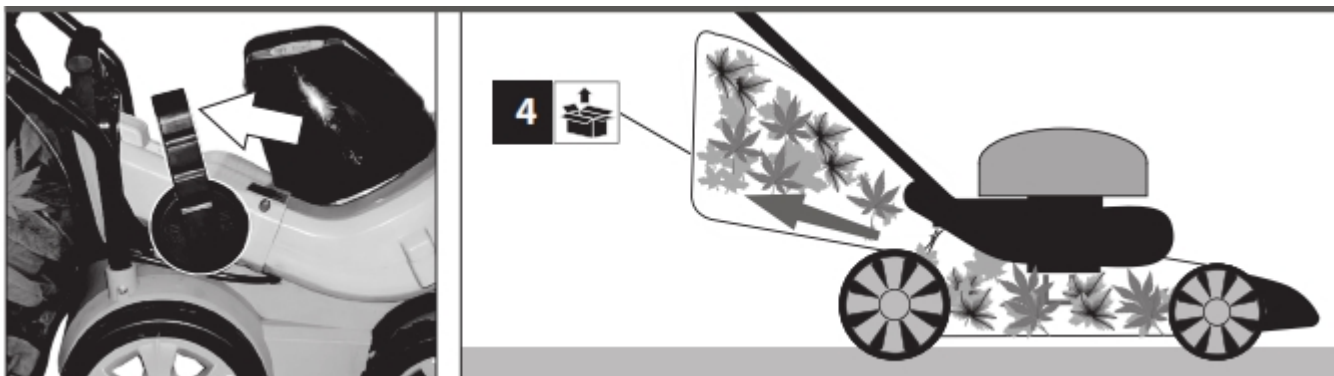

### 4.2 Blow function:

- 1) Put the adjustor on the right position.
- 2) Keep away from people and small animals.
- 3) Do not operate the machine in front of people or animals.
- 4) Make sure the machine is in full contact with the branches and leaves.

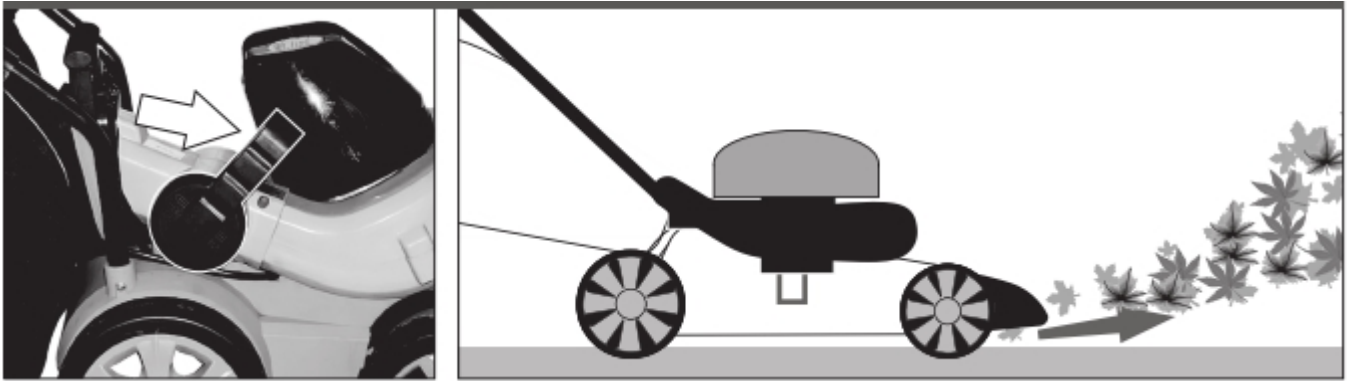

## 5. MAINTENANCE AND STORAGE

**WARNING! Do not use products that can damage the device (abrasive, corrosive, alcohols, steam cleaners, abrasive cloths, scrapers, etc.).**

**Do not install the appliance in a dishwasher for cleaning!**

**The unit must be completely switched off, unplugged, and cool before cleaning.**

### a. Care

**After each use:**

- Remove the collection bag and empty its contents into a dustbin.
- Use a brush to remove debris from fan and inside the tube.
- If necessary, you can clean the body of the tool with a soft dry cloth.

### b. Maintenance

**After each use:**

- Check all nuts, bolts and screws are tight and that the safety devices are properly positioned.
- Check if the machine has not suffered damage. If the machine is damaged, you will need to hire a qualified technician to inspect the machine and makes repairs.

### c. Storage

- Always clean the tool before storage.
- The tool, tube and collector bag must be stored in a well-ventilated place, stable and plane.
- The tool must be out of the reach of children.

## 6. Technical data

Voltage:.....230-240V~ 50Hz

Power: .....1600W

No-load Speed: .....13400/min

Max Air Speed: .....270km/h

Max Air Volume: .....17m<sup>3</sup>/min

Catcher Volume: .....45L

Wheel Diameter: .....Front 6", rear 7.5"

Type of protection .....IPX4

Weight.....9.5kg

Sound pressure level LpA

Measured at the operator

position, behind the handle.....LPA: 95 dB(A), K=3dB(A)

Guaranteed sound power level L<sub>WA</sub>

according to 2000/14/EC.....111 dB(A)

Vibration total values (triaxial vector sum) determined according to EN 50636:

Vibration emission value ah..... 1,6 m/s<sup>2</sup> Uncertainty K = 1,5 m/s<sup>2</sup>

## 7. DISPOSAL



Electrical products should not be discarded with household products. According to the European Directive 2012/19/EC on waste electrical and electronic equipment and its implementation into national law, electrical products used must be collected separately and disposed of at collection points provided for this purpose. Talk with your local authorities or dealer for advice on recycling.

## 8.DECLARATION OF CONFORMITY



BUILDER SAS

ZI, 32 rue, Aristide Bergès – 31270 Cugnaux - France

Tel: +33 (0)5.34.502.502 Fax: +33 (0)5.34.502.503

States that the designated below machine:

Garden Blower Vacuum

FASBE1600 /FASBE1600-UK

Serial number: 20210454012-20210454286

Developed, designed and manufactured in accordance with the requirements of directives:

Machinery Directive 2006/42/EC

EMC Directive 2014/30/EU

ROHS Directive (EU)2015/863 amending 2011/65/EU

Directive Noise 2000/14/EC Annex V and 2005/88/EC

Sound pressure level.LPA: 95 dB(A), K=3dB(A)

Guaranteed sound power level LWA 111 dB(A)

Also meets the following standards

EN 60335-1:2012+A11:2014+A13:2017+A1:2019+A2:2019+A14:2019 ;

EN 50636-2-100:2014;; EN 62233:2008;

EN 55014-1:2017; EN55014-2:2015; EN IEC61000-3-2:2019; EN 61000-3-3:2013+A1:2019

EN 61000-3-11: 2000

Philippe MARIE/PDG

A handwritten signature in black ink, appearing to read "Philippe Marie".

Cugnaux, 25/03/2021

Responsible of the technical file: Mr Olivier PATRIARCA



## 9. WARRANTY



### WARRANTY

The manufacturer guarantees the product against defects in material and workmanship for a period of 2 years from the date of the original purchase. The warranty only applies if the product is for household use. The warranty does not cover breakdowns due to normal wear and tear.

The manufacturer agrees to replace parts identified as defective by the designated distributor. The manufacturer does not accept responsibility for the replacement of the machine, in whole or in part, and/or ensuing damage.

**The warranty does not cover breakdowns due to:**

- insufficient maintenance.
- abnormal assembly, adjustment or operations of the product.
- parts subject to normal wear and tear.

**The warranty does not extend to:**

- shipping and packaging costs.
- using the tool for a purpose other than that for which it was designed.
- the use and maintenance of the machine done in a manner not described in the user manual.

Due to our policy of continuous product improvement, we reserve the right to alter or change specifications without notice. Consequently, the product may be different from the information contained therein, but a modification will be undertaken without notice if it is recognized as an improvement of the preceding characteristic.

#### **READ THE MANUAL CAREFULLY BEFORE USING THE MACHINE.**

When ordering spare parts, please indicate the part number or code, you can find this in the spare parts list in this manual. Keep the purchase receipt; without it, the warranty is invalid. To help you with your product, we invite you to contact us by phone or via our website:

- **+33 (0)9.70.75.30.30**
- **<https://services.swap-europe.com/contact>**

You must create a "ticket" via the web platform.

- Register or create your account.
- Indicate the reference of the tool.
- Choose the subject of your request.
- Describe your problem.
- Attach these files: invoice or sales receipt, photo of the identification plate (serial number), photo of the part you need (for example: pins on the transformer plug which are broken).



# 10. PRODUCT FAILURE

## WHAT TO DO IF MY MACHINE BREAKS DOWN?

### If you bought your product in a store:

- a) Empty the fuel tank.
- b) Make sure that your machine is complete with all accessories supplied, and clean! If this is not the case, the repairer will refuse the machine.

Go to the store with the complete machine and with the receipt or invoice.

### If you bought your product on a website:

- a) Empty the fuel tank.
- b) Make sure that your machine is complete with all accessories supplied, and clean! If this is not the case, the repairer will refuse the machine.
- c) Create a SWAP-Europe service ticket on the site: <https://services.swap-europe.com> When making the request on SWAP-Europe, you must attach the invoice and the photo of the nameplate (serial number).
- d) Contact the repair station to make sure it is available before dropping off the machine.

Go to the repair station with the complete machine packed, accompanied by the purchase invoice and the station support sheet downloadable after the service request is completed on the SWAP-Europe site

For machines with engine failure from manufacturers BRIGGS & STRATTON, HONDA and RATO, please refer to the following instructions.

Repairs will be done by approved engine manufacturers of these manufacturers, see their site:

- <http://www.briggsandstratton.com/eu/fr>
- <http://www.honda-engines-eu.com/fr/service-network-page;jsessionid=5EE8456CF39CD572AA2AEEDFD290CDAE>
- <https://www.rato-europe.com/it/service-network>

**Please keep your original packaging to allow for after-sales service returns or pack your machine with a similar cardboard box of the same dimensions.**

**For any question concerning our after-sales service you can make a request on our website <https://services.swap-europe.com>**

**Our hotline remains available at +33 (9) 70 75 30 30.**



# 11. WARRANTY EXCLUSIONS

## THE WARRANTY DOES NOT COVER:

- Start-up and setting up of the product.
- Damage resulting from normal wear and tear of the product.
- Damage resulting from improper use of the product.
- Damage resulting from assembly or start-up not in accordance with the user manual.
- Breakdowns related to carburetion beyond 90 days and fouling of carburetors.
- Periodic and standard maintenance events.
- Actions of modification and dismantling that directly void the warranty.
- Products whose original authentication marking (brand, serial number) has been degraded, altered or withdrawn.
- Replacement of consumables.
- The use of non-original parts.
- Breakage of parts following impacts or projections.
- Accessories breakdowns.
- Defects and their consequences linked to any external cause.
- Loss of components and loss due to insufficient screwing.
- Cutting components and any damage related to the loosening of parts.
- Overload or overheating.
- Poor power supply quality: faulty voltage, voltage error, etc.
- Damages resulting from the deprivation of enjoyment of the product during the time necessary for repairs and more generally the costs related to the immobilization of the product.
- The costs of a second opinion established by a third party following an estimate by a SWAP-Europe repair station
- The use of a product which would show a defect or a breakage which was not the subject of an immediate report and/or repair with the services of SWAP-Europe.
- Deterioration linked to transport and storage\*.
- Launchers beyond 90 days.
- Oil, petrol, grease.
- Damages related to the use of non-compliant fuels or lubricants.

\* In accordance with transport legislation, damage related to transport must be declared to carriers within 48 hours maximum after observation by registered letter with acknowledgement of receipt.

This document is a supplement to your notice, a non-exhaustive list.

**Attention:** all orders must be checked in the presence of the delivery person. In case of refusal by the delivery person, it you must simply refuse the delivery and notify your refusal.

**Reminder:** the reserves do not exclude the notification by registered letter with acknowledgement within 72 hours.

### Information:

Thermal devices must be wintered each season (service available on the SWAP-Europe site). Batteries must be charged before being stored.