

Energizer®



MITER SAW

EZSO14210

USER GUIDE

CAUTION: Read this manual before use this machine!

Energizer®

©2021 Energizer. Energizer and certain graphic designs are trademarks of Energizer Brands, LLC and related subsidiaries and are used under license by Builder SAS. All other brand names are trademarks of their respective owners. Neither Builder SAS nor Energizer Brands, LLC is affiliated with the respective owners of their trademarks.

Let's get started.

You're excited to power up, so we'll keep this brief!

CONTENTS

1. SAFETY INSTRUCTIONS	5
2. TECHNICAL DATA	10
3. DESCRIPTION	12
4. INTENDED USE	16
5. BEFORE STARTING THE EQUIPMENT	17
6. ATTACHMENT AND OPERATION	18
7. TRANSPORT	21
8. MAINTENANCE	21
9. STORAGE	21
10. ELECTRICAL CONNECTION	22
11. TROUBLESHOOTING	23
12. DISPOSAL AND RECYCLING	23
13. DECLARATION OF CONFORMITY	24
14. WARRANTY	25
15. PRODUCT FAILURE	26
16. WARRANTY EXCLUSIONS	27

1. SAFETY INSTRUCTIONS

1.1 GENERAL POWER TOOL SAFETY WARNINGS

 **WARNING** Read all safety warnings, instructions, illustrations and specifications provided with this power tool. Failure to follow all instructions listed below may result in electric shock, fire and/or serious injury.

Save all warnings and instructions for future reference.

The term "power tool" in the warnings refers to your mains-operated (corded) power tool or battery-operated (cordless) power tool.

1) Work area safety

- a) **Keep work area clean and well lit.** Cluttered or dark areas invite accidents.
- b) **Do not operate power tools in explosive atmospheres, such as in the presence of flammable liquids, gases or dust.** Power tools create sparks which may ignite the dust or fumes.
- c) **Keep children and bystanders away while operating a power tool.** Distractions can cause you to lose control.

2) Electrical safety

- a) **Power tool plugs must match the outlet. Never modify the plug in any way. Do not use any adapter plugs with earthed (grounded) power tools.** Unmodified plugs and matching outlets will reduce risk of electric shock.
- b) **Avoid body contact with earthed or grounded surfaces, such as pipes, radiators, ranges and refrigerators.** There is an increased risk of electric shock if your body is earthed or grounded.
- c) **Do not expose power tools to rain or wet conditions.** Water entering a power tool will increase the risk of electric shock.
- d) **Do not abuse the cord. Never use the cord for carrying, pulling or unplugging the power tool. Keep cord away from heat, oil, sharp edges or moving parts.** Damaged or entangled cords increase the risk of electric shock.
- e) **When operating a power tool outdoors, use an extension cord suitable for outdoor use.** Use of a cord suitable for outdoor use reduces the risk of electric shock.
- f) **If operating a power tool in a damp location is unavoidable, use a residual current device (RCD) protected supply.** Use of an RCD reduces the risk of electric shock.

3) Personal safety

- a) **Stay alert, watch what you are doing and use common sense when operating a power tool. Do not use a power tool while you are tired or under the influence of drugs, alcohol or medication.** A moment of inattention while operating power tools may result in serious personal injury.
- b) **Use personal protective equipment. Always wear eye protection.** Protective equipment such as a dust mask, non-skid safety shoes, hard hat or hearing protection used for appropriate conditions will reduce personal injuries.
- c) **Prevent unintentional starting. Ensure the switch is in the off-position before connecting to power source and/or battery pack, picking up or carrying the tool.** Carrying power tools with your finger on the switch or energising power tools that have the switch on invites accidents.
- d) **Remove any adjusting key or wrench before turning the power tool on.** A wrench or a key left attached to a rotating part of the power tool may result in personal injury.
- e) **Do not overreach. Keep proper footing and balance at all times.** This enables better control of the power tool in unexpected situations.
- f) **Dress properly. Do not wear loose clothing or jewellery. Keep your hair and clothing away from moving parts.** Loose clothes, jewellery or long hair can be caught in moving parts.
- g) **If devices are provided for the connection of dust extraction and collection facilities, ensure these are connected and properly used.** Use of dust collection can reduce dust-related hazards.
- h) **Do not let familiarity gained from frequent use of tools allow you to become complacent and ignore tool safety principles.** A careless action can cause severe injury within a fraction of a second.

4) Power tool use and care

- a) **Do not force the power tool. Use the correct power tool for your application.** *The correct power tool will do the job better and safer at the rate for which it was designed.*
- b) **Do not use the power tool if the switch does not turn it on and off.** *Any power tool that cannot be controlled with the switch is dangerous and must be repaired.*
- c) **Disconnect the plug from the power source and/or remove the battery pack, if detachable, from the power tool before making any adjustments, changing accessories, or storing power tools.** *Such preventive safety measures reduce the risk of starting the power tool accidentally.*
- d) **Store idle power tools out of the reach of children and do not allow persons unfamiliar with the power tool or these instructions to operate the power tool.** *Power tools are dangerous in the hands of untrained users.*
- e) **Maintain power tools and accessories. Check for misalignment or binding of moving parts, breakage of parts and any other condition that may affect the power tool's operation. If damaged, have the power tool repaired before use.** *Many accidents are caused by poorly maintained power tools.*
- f) **Keep cutting tools sharp and clean.** *Properly maintained cutting tools with sharp cutting edges are less likely to bind and are easier to control.*
- g) **Use the power tool, accessories and tool bits etc. in accordance with these instructions, taking into account the working conditions and the work to be performed.** *Use of the power tool for operations different from those intended could result in a hazardous situation.*
- h) **Keep handles and grasping surfaces dry, clean and free from oil and grease.** *Slippery handles and grasping surfaces do not allow for safe handling and control of the tool in unexpected situations.*

5) Service

Have your power tool serviced by a qualified repair person using only identical replacement parts. *This will ensure that the safety of the power tool is maintained.*

1.2 SAFETY INSTRUCTIONS FOR MITER SAWS

- a) **Miter saws are intended to cut wood or wood-like products, they cannot be used with abrasive cut-off wheels for cutting ferrous material such as bars, rods, studs, etc.** *Abrasive dust causes moving parts such as the lower guard to jam. Sparks from abrasive cutting will burn the lower guard, the kerf insert and other plastic parts.*
- b) **Use clamps to support the workpiece whenever possible. If supporting the workpiece by hand, you must always keep your hand at least 100 mm from either side of the saw blade. Do not use this saw to cut pieces that are too small to be securely clamped or held by hand. If your hand is placed too close to the saw blade, there is an increased risk of injury from blade contact.**
- c) **The workpiece must be stationary and clamped or held against both the fence and the table. Do not feed the workpiece into the blade or cut "freehand" in any way. Unrestrained or moving workpieces could be thrown at high speeds, causing injury.**
- d) **Push the saw through the workpiece. Do not pull the saw through the workpiece. To make a cut, raise the saw head and pull it out over the workpiece without cutting, start the motor, press the saw head down and push the saw through the workpiece. Cutting on the pull stroke is likely to cause the saw blade to climb on top of the workpiece and violently throw the blade assembly towards the operator.**
NOTE the above warning is omitted for a simple pivoting arm miter saw.
- e) **Never cross your hand over the intended line of cutting either in front or behind the saw blade.** *Supporting the workpiece "cross handed" i.e. holding the workpiece to the right of the saw blade with your left hand or vice versa is very dangerous.*
- f) **Do not reach behind the fence with either hand closer than 100 mm from either side of the saw blade, to remove wood scraps, or for any other reason while the blade is spinning.** *The proximity of the spinning saw blade to your hand may not be obvious and you may be seriously injured.*
- g) **Inspect your workpiece before cutting. If the workpiece is bowed or warped, clamp it with the outside bowed face toward the fence. Always make certain that there is no gap between the workpiece, fence and table along the line of the cut. Bent or warped workpieces can twist or shift and may cause binding on the spinning saw blade while cutting. There should be no nails or foreign objects in the workpiece.**

- h) **Do not use the saw until the table is clear of all tools, wood scraps, etc., except for the workpiece.** *Small debris or loose pieces of wood or other objects that contact the revolving blade can be thrown with high speed.*
- i) **Cut only one workpiece at a time.** *Stacked multiple workpieces cannot be adequately clamped or braced and may bind on the blade or shift during cutting.*
- j) **Ensure the miter saw is mounted or placed on a level, firm work surface before use.** *A level and firm work surface reduces the risk of the miter saw becoming unstable.*
- k) **Plan your work. Every time you change the bevel or miter angle setting, make sure the adjustable fence is set correctly to support the workpiece and will not interfere with the blade or the guarding system.** *Without turning the tool "ON" and with no workpiece on the table, move the saw blade through a complete simulated cut to assure there will be no interference or danger of cutting the fence.*
NOTE the phrase "bevel or" does not apply for saws without bevel adjustment.
- l) **Provide adequate support such as table extensions, saw horses, etc. for a workpiece that is wider or longer than the table top.** *Workpieces longer or wider than the miter saw table can tip if not securely supported. If the cut-off piece or workpiece tips, it can lift the lower guard or be thrown by the spinning blade.*
- m) **Do not use another person as a substitute for a table extension or as additional support.** *Unstable support for the workpiece can cause the blade to bind or the workpiece to shift during the cutting operation pulling you and the helper into the spinning blade.*
- n) **The cut-off piece must not be jammed or pressed by any means against the spinning saw blade.** *If confined, i.e. using length stops, the cut-off piece could get wedged against the blade and thrown violently.*
- o) **Always use a clamp or a fixture designed to properly support round material such as rods or tubing.** *Rods have a tendency to roll while being cut, causing the blade to "bite" and pull the work with your hand into the blade.*
- p) **Let the blade reach full speed before contacting the workpiece.** *This will reduce the risk of the workpiece being thrown.*
- q) **If the workpiece or blade becomes jammed, turn the miter saw off. Wait for all moving parts to stop and disconnect the plug from the power source and/or remove the battery pack. Then work to free the jammed material.** *Continued sawing with a jammed workpiece could cause loss of control or damage to the miter saw.*
- r) **After finishing the cut, release the switch, hold the saw head down and wait for the blade to stop before removing the cut-off piece.** *Reaching with your hand near the coasting blade is dangerous.*
- s) **Hold the handle firmly when making an incomplete cut or when releasing the switch before the saw head is completely in the down position.** *The braking action of the saw may cause the saw head to be suddenly pulled downward, causing a risk of injury.*

1.3 ADDITIONAL INSTRUCTIONS

- When using the saw, wear personal protective equipment such as safety goggles or a screen, helmet, dust mask, gloves, non-slip footwear and protective clothing.
- Ensure that there is sufficient, generalized or localized lighting.
- Do not use the saw when the protective parts are not in place.
- Do not use the saw to cut metal or masonry parts.
- Do not allow persons under 18 to operate the tool.
- Ensure that users of this tool have received professional training and know how to set and use this tool.
- Do not use the saw to cut firewood
- Remove all stumbling blocks from the work area.
- Report or record any defects as soon as possible, including the guards and the saw blade.
- Install the saw as much as possible on a work stand. Always stay on the side when the saw is turning.
- Never use a saw blade that is cracked or deformed.
- When cutting round wood, use a clamping assembly to prevent slippage of the workpiece.
- Do not use your hand to remove sawdust, chips or debris near the saw blade.
- Use only blades recommended by the manufacturer that comply with EN847-1.
- Do not use high speed steel blades (HSS blades).
- If the plate inserted on the swivel table is worn or damaged, have it replaced by an authorized service

center.

- Objects such as cloth, strings, should never be left in the working zone. Avoid cutting nails. Check the workpiece and remove all nails and other foreign objects before starting the machine.
- Hold the workpiece firmly.
- Avoid collecting debris or sawdust on the saw before the saw is completely stopped and the blade guard is in the open position.
- Do not attempt to release a blocked blade before stopping the machine by pressing the switch
- Do not attempt to slow down or stop the blade when it is still in the workpiece.
- Let the machine stop by itself.
- When you want to pause, turn off the power and wait for the saw to stop completely before leaving the work area.
- Periodically check that all fasteners, screws, bolts and nuts are properly tightened.
- Do not put materials or equipment above the saw to prevent the possibility of an unfortunate fall.
- Use the saw to cut parts that are insulated from electricity. If you accidentally cut a wire hidden in the workpiece or cut the power cable of the saw, the metal parts of the saw are covered by the current, the power must then be switched off immediately and the plug removed from the saw outlet.
- Never use the saw near any flammable liquid or gaseous material.
- Note and remember the direction of rotation of the motor and that of the blade.
- Do not block the movable blade guard in the open position and make sure it can move freely and fully cover the blade teeth.
- Place a saw on a dust collecting bag and ensure it is working properly. As an operator, you need to know the factors that influence the severity of pollution, such as material type, performance, and setting of the dust collection or evacuation device. In any case we recommend the use of a dust mask.
- Wear gloves when handling saw blades and rough materials.
- Put the saw blades in a sheath during transport.
- Select the saw blades according to the type of material to be cut.
- Use sharp saw blades and observe the maximum speed marked on the blade.
- Redouble your attention by machining a groove.
- The miter saw can be transported safely by the main handle, but only when it has been disconnected from the power outlet and locked in the locked position.
- Do not use the saw when the guards are not properly assembled, in good condition or well maintained.
- Make sure that the arm is securely secured during bevel cutting.
- Apply the workpiece strongly against the swivel table on which there should be no other pieces of wood.
- Ensure that you have received training and / or training and know how to adjust and use this tool.
- Use blades that are properly sharpened and do not exceed the maximum rated speed.
- Do not pick up debris from the cutting area until the blade guard closes and the saw is completely stopped.
- Attach the miter saw to a workbench if possible.
- When cutting a long piece that extends far beyond the width of the table, supports should be used to support the ends of the workpiece at the same height as the cutting table. The supports must be positioned so that the workpiece does not fall to the ground when the cutting has finished. If the part is very long, several supports must be provided.
- Use only a saw blade diameter in accordance with the markings on the saw.
- Use only saw blades that are marked with a speed equal or higher than the speed marked on the tool.
- Adjust the saw for proper cutting capacity, if applicable.
- If adjustable and/or removable workpiece support extensions are provided always fix and use these extensions during operation.
- Avoid overheating the saw blade tips
- Always check if the saw blade guard is working properly. It shall be well assembled, and it shall be easily moving with hand and that it can be locked when operating the tool (see in instructions for use).

1.4 RESIDUAL RISKS



Warning: When using a power tool, basic safety precautions should be taken to avoid the risk of fire, electric shock or injury to persons.









Please read the additional safety instructions in this manual carefully and note that even if the power tool is used in accordance with the operating instructions, it is not entirely certain that all residual risk factors will be eliminated. The following hazards can occur:

- Contact with blade.
- Rebound of the workpiece or debris of the workpiece
- Fracture of the blade.
- Ejection of debris from the machined part.
- Hearing damage if you do not wear ear plugs.
- Projection of wood chips that are harmful to health when the tool is used in a poorly sealed room.

It is therefore important to take preventive measures:

- Always use a sawdust disposal device if possible.
- Do not use deformed or cracked blades.
- Remove the plug from the power tool before any adjustment or maintenance, including replacement of the blades.
- Choose a suitable blade for the material to be cut.
- Do not use the saw to cut material other than those designated by the manufacturer
- The miter saw can be transported safely by the main handle, but only when it has been disconnected from the power outlet and locked in the locked position.
- Do not use the saw when the guards are not properly assembled, in good condition or properly maintained.
- Make sure that the arm is securely secured during bevel cutting.
- Apply the workpiece strongly against the swivel table on which there should be no other pieces of wood.
- Install sufficient lighting.
- Make sure you have been trained or trained and know how to adjust and use this tool. Use blades that are properly sharpened and do not exceed the maximum rated speed.
- Do not pick up debris from the cutting area until the blade guard closes and the saw comes to a complete stop.
- Attach the miter saw to a workbench if possible.
- When cutting a long piece that extends far beyond the width of the table, supports must be used to support the ends of the workpiece at the same height as the cutting table.
- The supports must be positioned so that the workpiece does not fall to the ground when the cutting has finished. If the part is very long, several supports must be provided.
- Keep the floor area free of loose material e.g. chips and cut-offs;
- Ensure that any spacers and spindle rings used are suitable for the purpose as stated by the manufacturer.

1.5 SYMBOL EXPLANATION

	To reduce the risk of injury, the user must read and understand this manual before using this product.
	Wear ear protectors. Exposure to noise can cause hearing loss.
	Wear protective goggles.
	Wear respiratory protection.
	wear protective gloves
	Double insulation.
	Waste electrical products should not be disposed of with household waste. Please recycle where facilities exist. Check with your local authority or retailer for recycling advice.
	In accordance with essential applicable safety standards of European directives
	Do not touch

2. TECHNICAL DATA

Model	EZSO14210
Mains voltage/ frequency	220-240 V~50 Hz
Power	S1:1400W; S6(25%)1700W
Speed	4900/min
Type	Single Phase
Blade size	Ø210*Ø 30*48T*2.6 mm 7000/min
Tilting swing arm	45° G/D
Swivel base	45° G/D
Sound pressure level LpA	93 dB(A)
Sound power level LwA	104 dB(A)
Uncertainty K:	3 dB(A)
Max. Cutting depth at :	
90° x 90°	115 x 60 mm
90° x 45°	115 x 25 mm
45° x 90°	60 x 60 mm
45°*45°	80 x 25 mm
Table Tilting Range:	Left45° - Right45°
Saw Body Tilting:	45° - 45°

The vibration value does not exceed 2,5 m/s²

Information:

- The declared vibration total value has been measured in accordance with a standard test method and may be used for comparing one tool with another;
- The declared vibration total value may also be used in a preliminary assessment of exposure.

Warning:

- The vibration emission during actual use of the power tool can differ from the declared total value depending on the ways in which the tool is used;
- Need to identify safety measures to protect the operator that are based on an estimation of exposure in the actual conditions of use (taking account of all parts of the operating cycle such as the times when the tool is switched off and when it is running idle in addition to the trigger time)

3. PRODUCT DESCRIPTION

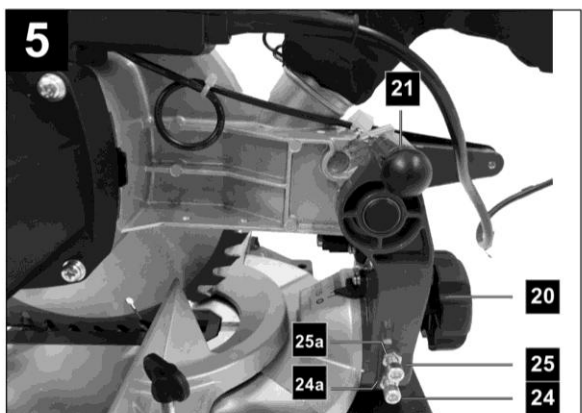
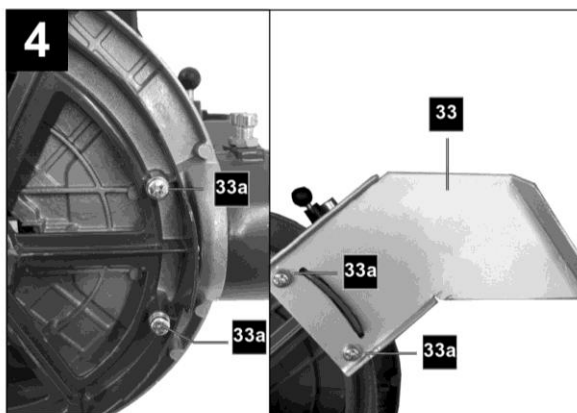
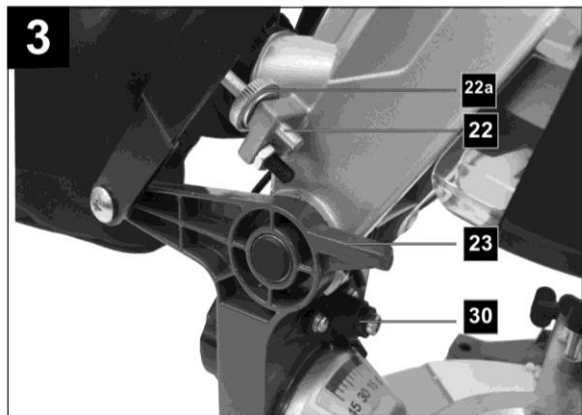
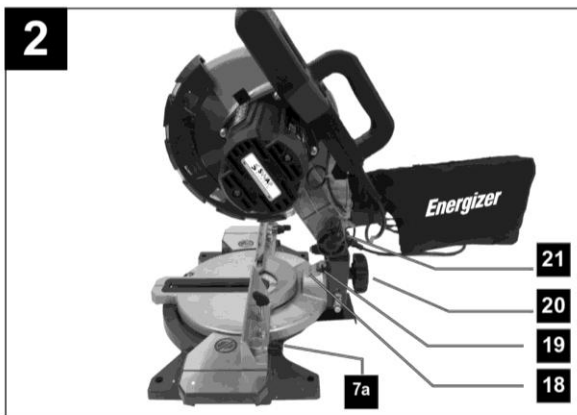
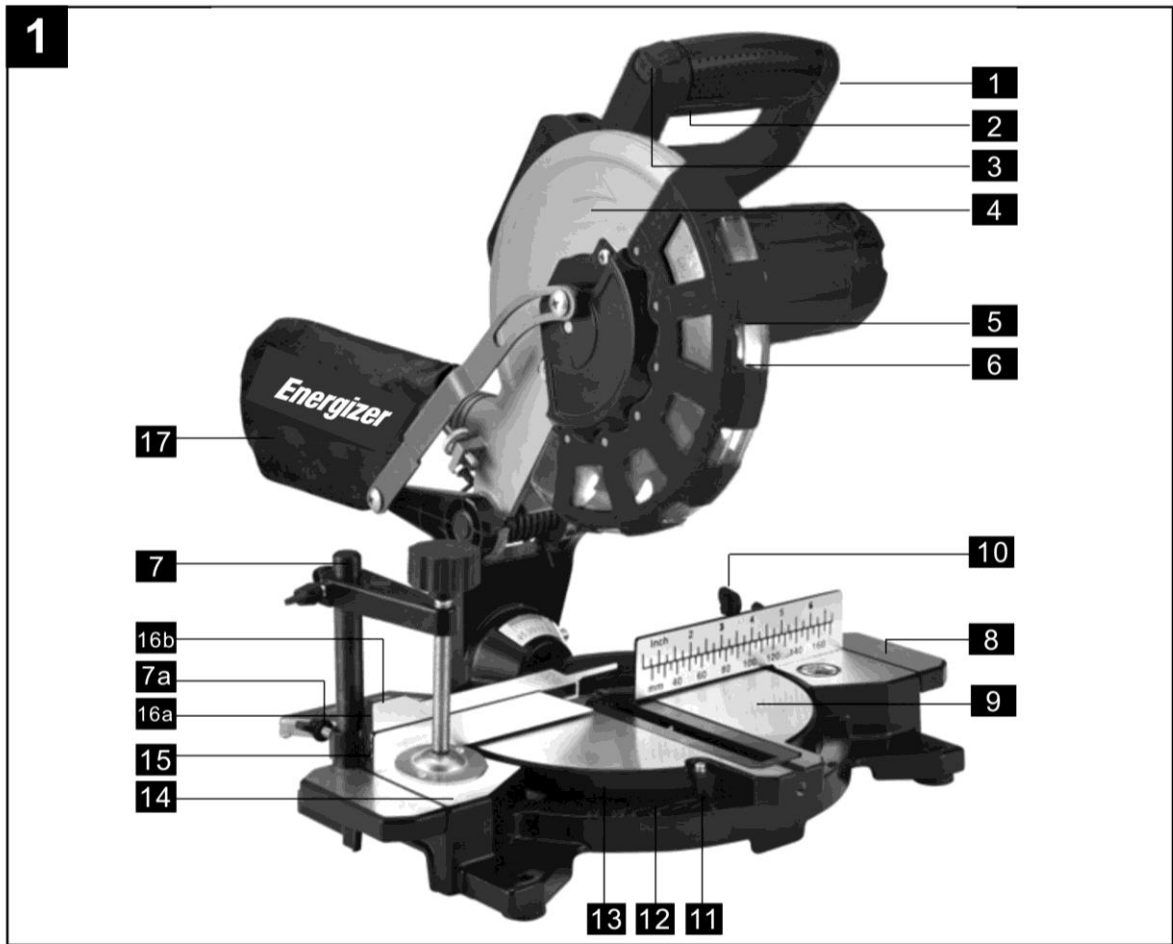

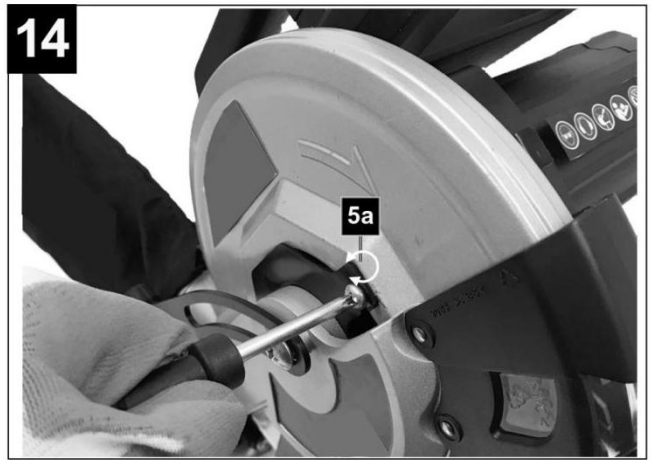
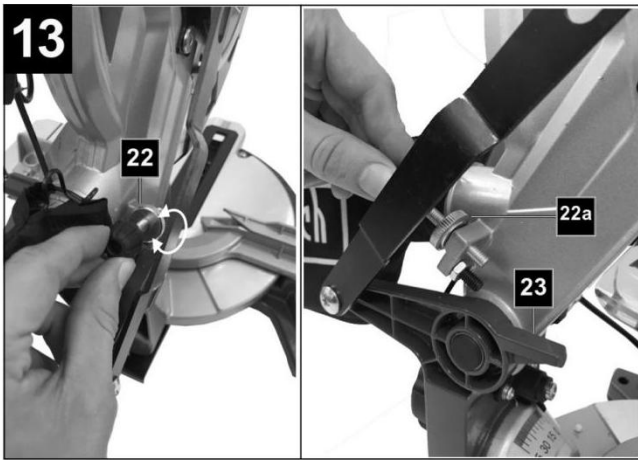
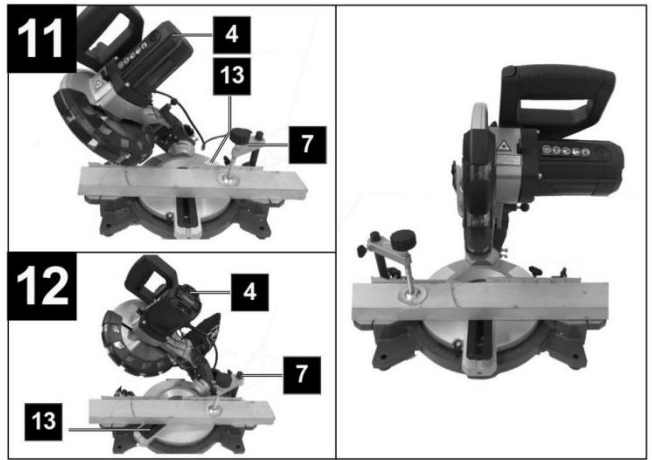
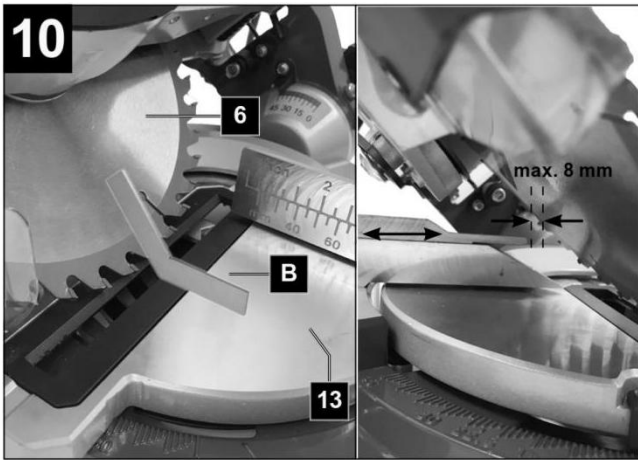
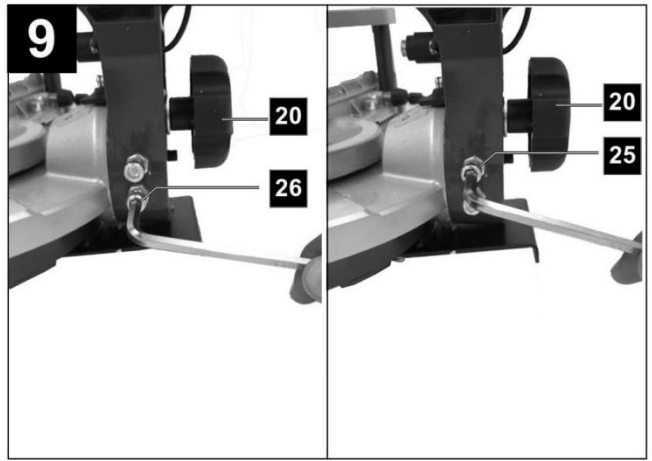
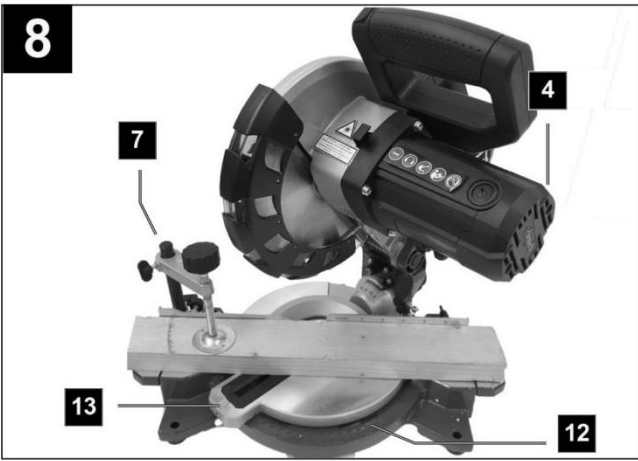
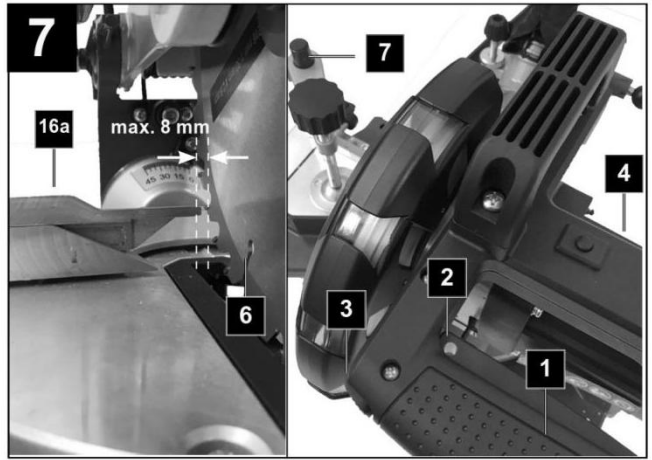
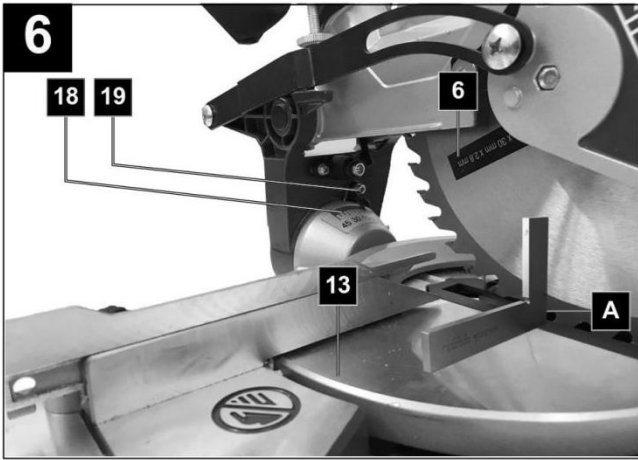

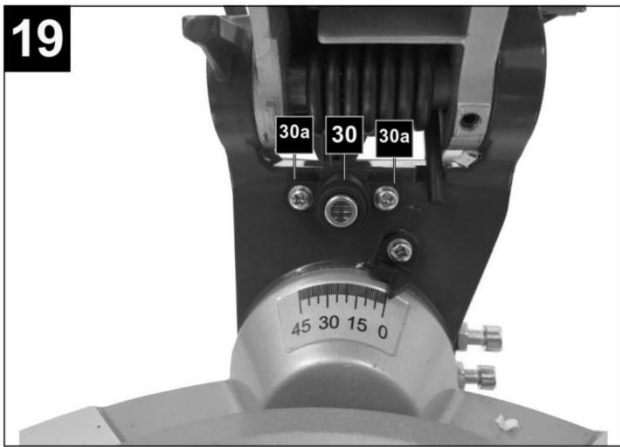
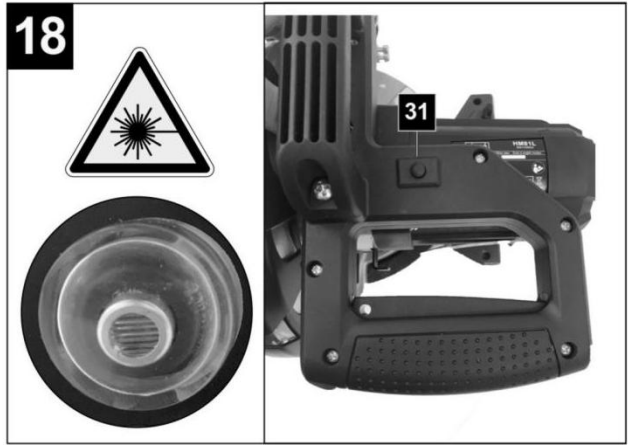
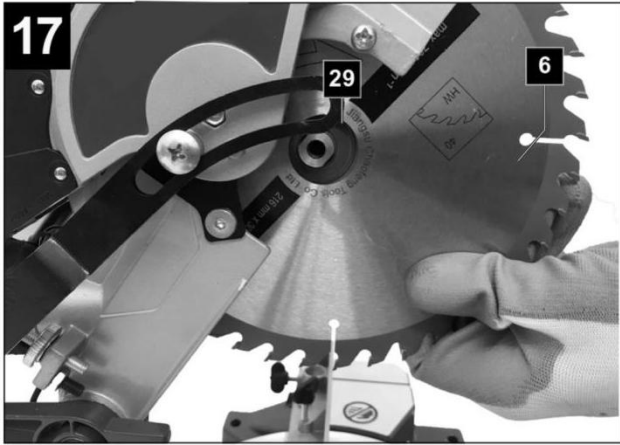
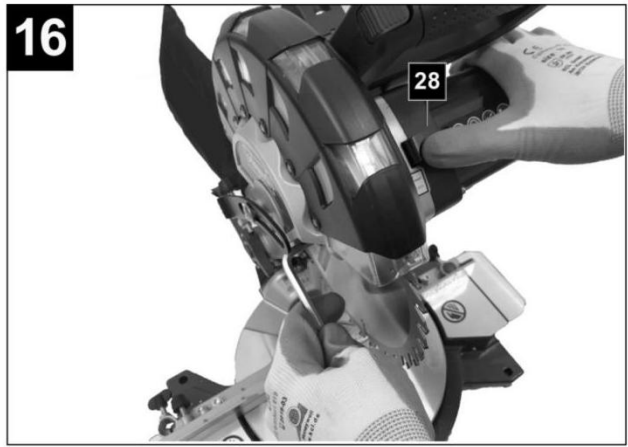
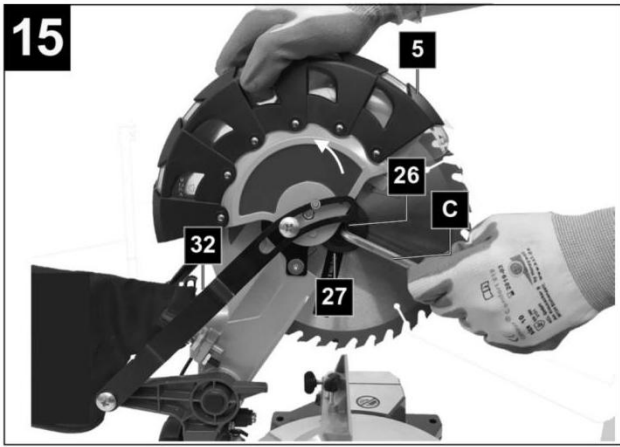

1	Handle	19	Pointer
2	ON/OFF switch	20	Set screw
3	Lock switch	21	Locking bolt
4	Machine head	22	Screw for cutting depth limiting
5	Moving saw blade guard	23	Stop for cutting depth limiting
6	Saw blade	24	Adjusting screw (90°)
7	Clamping device	25	Adjusting screw (45°)
8	Workpiece support	26	Flange screw
9	Table insert	27	Outer flange
10	Set screw for rotary table	28	Saw shaft lock
11	Pointer	29	Inner flange
12	Scale	30	N/A
13	Rotary table	31	N/A
14	Fixed saw table	32	Guide bracket
15	Stop rail	33	Tilt protection
16a	Movable stop rail	A	90° stop angle (not supplied)
16b	Set screw	B	45° stop angle (not supplied)
17	Sawdust bag	C	Allen key, 6 mm
18	Scale		

NOTE: THIS MODEL IS DELIVERED WITHOUT LASER AND WITHOUT LED INDICATOR. THE ILLUSTRATIONS IN THIS MANUAL MAY BE DIFFERENT THAN THE CURRENT MACHINE.

4. INTENDED USE

The miter saw is designed to crosscut wood respective of the machine's size. The saw is not designed for cutting firewood.



Warning! Do not use the saw to cut materials other than those specified described in manual.



Warning! The supplied saw blade is only intended for the sawing of wood! Do not use this blade for the sawing of firewood!

The equipment is to be used only for its prescribed purpose.

Any other use is deemed to be a case of misuse. The user / operator and not the manufacturer will be liable for any damage or injuries of any kind caused as a result of this.

The equipment is to be operated only with suitable saw blades. It is prohibited to use any type of cutting wheel.

To use the equipment properly you must also observe the safety information, the assembly instructions and the operating instructions to be found in this manual.

All persons who use and service the equipment have to be acquainted with this manual and must be informed about the equipment's potential hazards. It is also imperative to observe the accident prevention regulations in force in your area. The same applies for the general rules of health and safety at work.

The manufacturer will not be liable for any changes made to the equipment nor for any damage resulting from such changes. Even when the equipment is used as prescribed it is still impossible to eliminate certain residual risk factors. The following hazards may arise in connection with the machine's construction and design:

- Contact with the saw blade in the uncovered saw zone.
- Reaching into the running saw blade (cut injuries).
- Kick-back of workpieces and parts of workpieces.
- Saw blade fracturing.
- Catapulting of faulty carbide tips from the saw blade.
- Damage to hearing if hearing protection is not used as necessary.
- Harmful emissions of wood dust when used in closed rooms.
- Please note that our equipment has not been designed for use in commercial or industrial applications.

5. BEFORE STARTING THE EQUIPMENT

- Open the packaging and remove the device carefully.
- Remove the packaging material as well as the packaging and transport bracing (if available).
- Check that the delivery is complete.
- Check the device and accessory parts for transport damage.
- If possible, store the packaging until the warranty period has expired.



The device and packaging materials are not toys! Children must not be allowed to play with plastic bags, and small parts! There is a risk of swallowing and suffocation!

- The equipment must be set up where it can stand securely. Secure the machine on a workbench or a base frame with 4 screws (not included in delivery) using the holes on the fixed saw table (14).
- Mount the tilt protection (33).
- All covers and safety devices have to be properly fitted before the equipment is switched on.
- It must be possible for the blade to run freely.
- When working with wood that has been processed before, watch out for foreign bodies such as nails or screws, etc.
- Before you press the ON/OFF switch, check that the saw blade is fitted correctly. Moving parts must run smoothly.
- Before you connect the equipment to the power supply make sure the data on the rating plate are identical to the mains data.

Checking the moving saw blade guard safety device (5)

The saw blade guard protects against accidental contact with the saw blade and from chips flying around.

Check function

To do so, fold the saw downwards:

The saw blade guard must provide free access to the saw blade without touching other parts.

When folding the saw upwards into the starting position, the saw blade guard must cover the saw blade automatically.

6. ATTACHMENT AND OPERATION

6.1 ATTACHING THE MITER SAW (FIG. 1/2/4/5)

- In order to adjust the rotary table (13), loosen the set screw (10) approximately 2 turns.
- Turn the rotary table (13) and pointer (11) to the de-sired angle measurement on the scale (12) and use the set screw (10) to secure it.
- Pressing the machine head (4) lightly downwards and removing the locking bolt (21) from the motor bracket at the same time disengages the saw from the lowest position.
- Swing the machine head (4) up.
- It is possible to secure the clamping devices (7) to the left or right on the fixed saw table (14). Insert the clamping devices (7) in the holes on the rear side of the stop rail (15) and secure it with the star grip screws (7a). For 0°-45° miter cuts, the clamping device (7) must only be mounted on the right side (see fig. 11-12).
- It is possible to tilt the machine head (4) a max. 45° to the left by loosening the set screw (20).

6.2 PRECISION ADJUSTMENT OF THE STOP FOR CROSSCUT 90° (FIG. 1/2/5/6)

- No stop angle included.
- Lower the machine head (4) and secure it using the locking bolt (21).
- Loosen the set screw (20).
- Position the angle stop (A) between the saw blade (6) and the rotary table (13).
- Loosen the lock nut (24a).
- Adjust the adjusting screw (24) until the angle between the saw blade (6) and rotary table (13) is 90°.
- Re-tighten the lock nut (24a).
- Subsequently check the position of the angle indicator. If necessary loosen the pointer (19) using a Philips screwdriver, set to position 0° on the angle scale (18) and re-tighten the retaining screw.

6.3 CROSSCUT 90° AND TURNTABLE 0° (FIG. 1/2/7)

Attention! For 90° crosscuts, the moveable stop rail (16a) must be fixed in the inner position.

- Open the set screw (16b) for the moveable stop rail (16a) and push the moveable stop rail (16a) inwards.
- The moveable stop rail (16a) must be locked in a position far enough from the inner position that the distance between the stop rail (16a) and the saw blade (6) is no more than 8 mm.
- Before making the cut, check that the stop rail (16a) and the saw blade (6) cannot collide.
- Re-tighten the set screw (16b).
- Move the machine head (4) to its upper position.
- Use the handle (1) to push back the machine head (4) and fix it in this position if required (dependent on the cutting width).
- Place the piece of wood to be cut at the stop rail (15) and on the turntable (13).
- Lock the material with the clamping devices (7) on the fixed saw table (14) to prevent the material from moving during the cutting operation.
- Release the lock switch (3) and press the ON/OFF switch (2) to start the motor.
- When the cutting operation is completed, move the machine head back to its upper (home) position and release the ON/OFF button (2).

 **Warning!** The machine executes an upward stroke automatically due to the return spring, i.e. do not release the handle (1) after completing the cut; instead allow the machine head to move upwards slowly whilst applying light counter pressure.

6.4 CROSSCUT 90° AND TURNTABLE 0° - 45° (FIG. 1/7/8)

The miter saw can be used to make crosscuts of 0° -45° to the left and 0° -45° to the right in relation to the stop rail.

Important ! For 90° crosscuts, the moveable stop rail (16a) must be fixed in the inner position.

- Open the set screw (16b) for the moveable stop rail (16a) and push the moveable stop rail (16a) inwards.

- The moveable stop rail (16a) must be fixed far enough in front of the innermost position that the distance between the stop rail (16a) and the saw blade (6) amounts to a minimum of 8 mm.
- Before making the cut, check that the stop rail (16a) and the saw blade (6) cannot collide.
- Secure the set screw (16b) again.
- Loosen the set screw (10).
- Use the handle (1) to adjust the rotary table to the desired angle.
- The pointer (11) on the rotary table must match the desired angle on the scale (12) on the fixed saw table (14).
- Re-tighten the set screw (10) to secure the rotary table (13).
- Cut as described under section 6.3.

6.5 PRECISION ADJUSTMENT OF THE STOP FOR MITER CUT 45° (FIG. 1/2/5/9/10)

- No stop angle included.
- Lower the machine head (4) and secure it using the locking bolt (21).
- Fix the rotary table (13) in the 0° position.
- Attention! For miter cuts (inclined saw head), the moveable stop rails (16a) must be fixed in the outer position.
- Open the set screw (16b) for the moveable stop rail (16a) and push the moveable stop rail (16a) outwards.
- The moveable stop rail (16a) must be fixed far enough in front of the innermost position that the distance between the stop rail (16a) and the saw blade (6) amounts to a maximum of 8 mm.
- Before making a cut, check that the stop rail (16a) and the saw blade (6) cannot collide.
- Loosen the set screw (20) and use the handle (1) to angle the machine head (4) 45° to the left.
- Position angle stop (B) between the saw blade (6) and rotary table (13).
- Loosen the lock nut (25a) and adjust the adjustment screw (25) until the angle between the saw blade (6) and the rotary table (13) is precisely 45°.
- Re-tighten the lock nut (25a).
- Subsequently check the position of the angle indicator. If necessary, loosen the pointer (19) using a Philips screwdriver, set to position 45° on the angle scale (18) and re-tighten the retaining screw.

6.6 MITER CUT 0°- 45° AND TURNTABLE 0° (FIG. 1/2/11)

The miter saw can be used to make miter cuts of 0° - 45° in relation to the work face.

 **Warning!** For miter cuts (inclined saw head), the moveable stop rails (16a) must be fixed in the outer position.

- Open the set screw (16b) for the moveable stop rail (16a) and push the moveable stop rail (16a) outwards.
- The moveable stop rail (16a) must be fixed far enough in front of the innermost position that the distance between the stop rail (16a) and the saw blade (6) amounts to a minimum of 8 mm.
- Before making a cut, check that the stop rail (16a) and the saw blade (6) cannot collide.
- Secure the set screw (16b) again.
- Move the machine head (4) to the top position.
- Fix the rotary table (13) in the 0° position.
- Loosen the set screw (20) and use the handle (1) to angle the machine head (4) to the left, until the pointer (19) indicates the desired angle measurement on the scale (18).
- Re-tighten the set screw (20).
- Cut as described in section 6.3.

6.7 MITER CUT 0°- 45° AND TURNTABLE 0°- 45° (FIG. 2/4/12)

The miter saw can be used to make miter cuts to the left of 0°- 45° in relation to the work face and, at the same time, 0°-45° to the left or 0°-45° to the right in relation to the stop rail (double miter cut).

 **Warning!** For miter cuts (inclined saw head), the moveable stop rails (16a) must be fixed in the outer position.

- Open the set screw (16b) for the moveable stop rail (16a) and push the moveable stop rail (16a) out-

wards.

- The moveable stop rail (16a) must be fixed far enough in front of the innermost position that the distance between the stop rail (16a) and the saw blade (6) amounts to a minimum of 8 mm.
- Before making a cut, check that the stop rail (16a) and the saw blade (6) cannot collide.
- Re-tighten the set screw (16b).
- Move the machine head (4) to its upper position.
- Release the rotary table (13) by loosening the set screw (10).
- Using the handle (1), set the rotary table (13) to the desired angle (refer also to point 8.4 in this regard).
- Re-tighten the set screw (10) to secure the rotary table (13).
- Undo the set screw (20).
- Use the handle (1) to tilt the machine head (4) to the left until it coincides with the required angle value (in this connection see also section 6.6).
- Re-tighten the set screw (20).
- Cut as described under section 6.3.

6.8 LIMITING THE CUTTING DEPTH (FIG. 3/13)

- The cutting depth can be infinitely adjusted using the screw (22). To do this, loosen the knurled nut (22a) on the screw (22). Turn the screw (22) in or out to set the required cutting depth. Then re-tighten the knurled nut (22a) on the screw (22).
- Check the setting by completing a test cut.

6.9 SAWDUST BAG (FIG. 1/21)

The saw is equipped with a debris bag (17) for sawdust and chips.

Squeeze together the metal ring on the dust bag and attach it to the outlet opening in the motor area.

The debris bag (17) can be emptied by means of a zipper at the bottom.

Connection to an external dust extractor

- Connect the vacuum hose with the dust extraction spout.
- The industrial vacuum cleaner must be suitable for the material being worked.
- When vacuuming dust that is especially detrimental to health or carcinogenic, use a special vacuum cleaner.

6.10 CHANGING THE SAW BLADE (FIG. 1/2/14-17)



Warning! Remove the power plug!

Important! Wear safety gloves when changing the saw blade. Risk of injury!

- Swing the machine head (4) upwards and lock with the locking bolt (21).
- Loosen the retaining screw (5a) of the cover using a Philips screwdriver.



Warning! Do not fully remove this screw.

- Fold the saw blade guard (5) upwards until the saw blade guard (5) is above the flange screw (26).
- With one hand insert the Allen key (C) in the flange screw (27).
- Hold the Allen key (C) and slowly close the saw blade guard (5) until it touches the Allen key (C).
- Firmly press the saw shaft lock (28) and slowly rotate the flange screw (26) in clockwise direction. The saw shaft lock (28) engages after no more than one rotation.
- Now, using a little more force, slacken the flange screw (27) in the clockwise direction.
- Turn the flange screw (26) right out and remove the outer flange (27).
- Take the blade (6) off the inner flange (29) and pull out downwards.
- Carefully clean the flange screw (26), outer flange (27) and inner flange (29).
- Fit and fasten the new saw blade (6) in reverse order.
- Important! The cutting angle of the teeth, in other words the direction of rotation of the saw blade (6) must coincide with the direction of the arrow on the housing.
- Before continuing your work, make sure that all safety devices are in good working condition.
- Important! Every time that you change the saw blade (6), check to see that it spins freely in the table insert (9) in both perpendicular and 45° angle settings.
- Important! The work to change and align the saw blade (6) must be carried out correctly.

7. TRANSPORT

Tighten the set screw (10) to lock the rotary table.

Press the machine head (4) downwards and secure with the locking bolt (21).

Carry the equipment by the fixed saw table.

8. MAINTENANCE



Warning! Prior to any adjustment, maintenance or service work, disconnect the mains power plug!

General maintenance measures

Wipe chips and dust off the machine from time to time using a cloth. In order to extend the service life of the tool, oil the rotary parts once monthly. Do not oil the motor.

When cleaning the plastic do not use corrosive products.

Cleaning the moving saw blade guard safety device (5)

Always check the saw blade guard for debris before using the machine.

Remove old sawdust and splinters using a brush or similar tool.

Brush inspection

Check the carbon brushes after the first 50 operating hours with a new machine, or when new brushes have been fitted. After carrying out the first check, repeat the check every 10 operating hours.

If the carbon is worn to a length of 6 mm, or if the spring or contact wire are burned or damaged, it is necessary to replace both brushes. If the brushes are found to be usable following removal, it is possible to reinstall them.

When servicing the carbon brushes, open the two latches counter clockwise (as shown in Figure 20). Then remove the carbon brushes.

Replace the carbon brushes in the reverse order.

9. STORAGE

Store the device and its accessories in a dark, dry and frost-proof place that is inaccessible to children.

The optimum storage temperature is between 5 and 30°C.

Store the electrical tool in its original packaging.

Cover the electrical tool in order to protect it from dust and moisture.

Store the operating manual with the electrical tool.

10. ELECTRICAL CONNECTION

The electrical motor installed is connected and ready for operation. The connection complies with the applicable VDE and DIN provisions.

The customer's mains connection as well as the extension cable used must also comply with these regulations.

- The product meets the requirements of EN 61000-3-11 and is subject to special connection conditions. This means that use of the product at any freely selectable connection point is not allowed.
- Given unfavorable conditions in the power supply the product can cause the voltage to fluctuate temporarily.
- The product is intended solely for use at connection points that a) do not exceed a maximum permitted supply impedance "Z" ($Z_{\max} = 0.382 \Omega$), or b) have a continuous current-carrying capacity of the mains of at least 100 A per phase.
- As the user, you are required to ensure, in consultation with your electric power company if necessary, that the connection point at which you wish to operate the product meets one of the two requirements, a) or b), named above.

Important information

In the event of an overloading the motor will switch itself off. After a cool-down period (time varies) the motor can be switched back on again.

Damaged electrical connection cable

The insulation on electrical connection cables is often damaged.

This may have the following causes:

- Passage points, where connection cables are passed through windows or doors.
- Kinks where the connection cable has been improperly fastened or routed.
- Places where the connection cables have been cut due to being driven over.
- Insulation damage due to being ripped out of the wall outlet.
- Cracks due to the insulation ageing.

Such damaged electrical connection cables must not be used and are life-threatening due to the insulation damage.

Check the electrical connection cables for damage regularly. Make sure that the connection cable does not hang on the power network during the inspection.

Electrical connection cables must comply with the applicable VDE and DIN provisions. Only use connection cables with the marking „H05VV-F“.

The printing of the type designation on the connection cable is mandatory.

AC motor:

The mains voltage must be 220-240 V~.

- Extension cables up to 25 m long must have a cross-section of 1.5 mm².
- Connections and repairs of electrical equipment may only be carried out by an electrician. Please provide the following information in the event of any enquiries:
 - Type of current for the motor
 - Machine data - type plate

11. TROUBLESHOOTING

PROBLEMS	POSSIBLE CAUSES	SOLUTIONS
The motor does not start	1. Under voltage 2. Poor connection	Check the connections and the mains voltage.
The motor does not start and disconnects.	1. Short circuit in the socket 2. Short circuit in the motor 3. Bad fuse, or cut circuit breaker	1. Check the plugs 2. Inspect the connections on the machine 3. Check the fuses
The motor heats up	The motor is overloaded	Reduce the load on the motor
The rotation speed drops	1. The motor is in short circuit 2. The tension drops 3. Bad fuse 4. Overheating motor	1. Check the connections on the motor and the insulation of the connections 2. Check the voltages and fuses 3. Reduce the load
The machine vibrates, trembles	1. The saw blade is not circular 2. The saw blade is damaged 3. The saw blade is badly fixed	1. Replace or sharpen the saw blade 2. Replace the blade with a suitable blade adapted for the materials to cut 3. Tighten the screw of the shaft
Burn points appear on the workpiece	1. Malfunction 2. The saw blade is dull or not suitable	1. Replace or sharpen the blade 2. Replace the blade with a suitable blade for the materials to cut
The cutting angle is not accurate	1. The alignment is bad	1. Check the tightness of the different axes
The blade engine block oscillates	1. The pivot is moving	1. Check the tightness of the pivot

12. DISPOSAL AND RECYCLING

The equipment is supplied in packaging to prevent it from being damaged in transit. The raw materials in this packaging can be reused or recycled. The equipment and its accessories are made of various types of material, such as metal and plastic. Defective components must be disposed of as special waste. Ask your dealer or your local council.



The packaging is wholly composed of environmentally-friendly materials that can be disposed of at a local recycling center. Contact your local refuse disposal authority for more details of how to dispose of your worn-out electrical devices.



Electrical products should not be discarded with household products. According to the European Directive 2012/19/EU on waste electrical and electronic equipment and its implementation into national law, electrical products used must be collected separately and disposed of at collection points provided for this purpose. Talk with your local authorities or dealer for advice on recycling.

13. CE DECLARATION OF CONFORMITY



Declaration of conformity

BUILDER SAS

32, rue Aristide Bergès –Z1 31270 Cugnaux France

Phone: +33 (0) 5.34.508.508

Fax: +33 (0)5.34.508.509

Declares that the machinery designated below:

MITER SAW

Model: EZSO14210

Serial number: 20210736140-20210737139

Complies with the provisions of the Directive “Machinery” 2006/42/EC and national laws transposing it:

Also complies with the following European directives:

EMC Directive 2014/30/EU

ROHS Directive (EU) 2015/863 amending
2011/65/EU

Also complies with European standards, with national standards and the following technical provisions:

EN62841-1:2015

EN62841-3-9:2015/A11:2017

EN 55014-1:2017

EN 55014-2:2015

EN 61000-3-2: 2014

EN 61000-3-11: 2000

Responsible of the technical file: Mr Olivier Patriarca

Cugnaux, 19/04/2021

Philippe MARIE

14. WARRANTY

Energizer[®]

WARRANTY

The manufacturer guarantees the product against defects in material and workmanship for a period of 2 years from the date of the original purchase. The warranty only applies if the product is for household use. The warranty does not cover breakdowns due to normal wear and tear.

The manufacturer agrees to replace parts identified as defective by the designated distributor. The manufacturer does not accept responsibility for the replacement of the machine, in whole or in part, and/or ensuing damage.

The warranty does not cover breakdowns due to:

- insufficient maintenance.
- abnormal assembly, adjustment or operations of the product.
- parts subject to normal wear and tear.

The warranty does not extend to:

- shipping and packaging costs.
- using the tool for a purpose other than that for which it was designed.
- the use and maintenance of the machine done in a manner not described in the user manual.

Due to our policy of continuous product improvement, we reserve the right to alter or change specifications without notice. Consequently, the product may be different from the information contained therein, but a modification will be undertaken without notice if it is recognized as an improvement of the preceding characteristic.

READ THE MANUAL CAREFULLY BEFORE USING THE MACHINE.

When ordering spare parts, please indicate the part number or code, you can find this in the spare parts list in this manual. Keep the purchase receipt; without it, the warranty is invalid. To help you with your product, we invite you to contact us by phone or via our website:

- **+33 (0)9.70.75.30.30**
- **<https://services.swap-europe.com/contact>**

You must create a "ticket" via the web platform.

- Register or create your account.
- Indicate the reference of the tool.
- Choose the subject of your request.
- Describe your problem.
- Attach these files: invoice or sales receipt, photo of the identification plate (serial number), photo of the part you need (for example: pins on the transformer plug which are broken).



15. PRODUCT FAILURE

WHAT TO DO IF MY MACHINE BREAKS DOWN?

If you bought your product in a store:

- a) Empty the fuel tank if your product has one.
- b) Make sure that your machine is complete with all accessories supplied, and clean! If this is not the case, the repairer will refuse the machine.

Go to the store with the complete machine and with the receipt or invoice.

If you bought your product on a website:

- a) Empty the fuel tank if your product has one.
- b) Make sure that your machine is complete with all accessories supplied, and clean! If this is not the case, the repairer will refuse the machine.
- c) Create a SWAP-Europe service ticket on the site: <https://services.swap-europe.com> When making the request on SWAP-Europe, you must attach the invoice and the photo of the nameplate (serial number).
- d) Contact the repair station to make sure it is available before dropping off the machine.

Go to the repair station with the complete machine packed, accompanied by the purchase invoice and the station support sheet downloadable after the service request is completed on the SWAP-Europe site

For machines with engine failure from manufacturers BRIGGS & STRATTON, HONDA and RATO, please refer to the following instructions.

Repairs will be done by approved engine manufacturers of these manufacturers, see their site:

- <http://www.briggsandstratton.com/eu/fr>
- <http://www.honda-engines-eu.com/fr/service-network-page;jsessionid=5EE8456CF39CD572AA2AEEDFD290CDAE>
- <https://www.rato-europe.com/it/service-network>

Please keep your original packaging to allow for after-sales service returns or pack your machine with a similar cardboard box of the same dimensions.

For any question concerning our after-sales service you can make a request on our website <https://services.swap-europe.com>

Our hotline remains available at +33 (9) 70 75 30 30.



16. WARRANTY EXCLUSIONS

THE WARRANTY DOES NOT COVER:

- Start-up and setting up of the product.
- Damage resulting from normal wear and tear of the product.
- Damage resulting from improper use of the product.
- Damage resulting from assembly or start-up not in accordance with the user manual.
- Breakdowns related to carburetion beyond 90 days and fouling of carburetors.
- Periodic and standard maintenance events.
- Actions of modification and dismantling that directly void the warranty.
- Products whose original authentication marking (brand, serial number) has been degraded, altered or withdrawn.
- Replacement of consumables.
- The use of non-original parts.
- Breakage of parts following impacts or projections.
- Accessories breakdowns.
- Defects and their consequences linked to any external cause.
- Loss of components and loss due to insufficient screwing.
- Cutting components and any damage related to the loosening of parts.
- Overload or overheating.
- Poor power supply quality: faulty voltage, voltage error, etc.
- Damages resulting from the deprivation of enjoyment of the product during the time necessary for repairs and more generally the costs related to the immobilization of the product.
- The costs of a second opinion established by a third party following an estimate by a SWAP-Europe repair station
- The use of a product which would show a defect or a breakage which was not the subject of an immediate report and/or repair with the services of SWAP-Europe.
- Deterioration linked to transport and storage*.
- Launchers beyond 90 days.
- Oil, petrol, grease.
- Damages related to the use of non-compliant fuels or lubricants.

* In accordance with transport legislation, damage related to transport must be declared to carriers within 48 hours maximum after observation by registered letter with acknowledgement of receipt.

This document is a supplement to your notice, a non-exhaustive list.

Attention: all orders must be checked in the presence of the delivery person. In case of refusal by the delivery person, it you must simply refuse the delivery and notify your refusal.

Reminder: the reserves do not exclude the notification by registered letter with acknowledgement within 72 hours.

Information:

Thermal devices must be wintered each season (service available on the SWAP-Europe site). Batteries must be charged before being stored.

Energizer®