

Energizer®



AIR CONDITIONER

EZ2600FC3A / EZ3500FC3A

USER GUIDE

CAUTION: Read this manual before use of this machine!

Energizer®

©2021 Energizer. Energizer and certain graphic designs are trademarks of Energizer Brands, LLC and related subsidiaries and are used under license by Builder SAS. All other brand names are trademarks of their respective owners. Neither Builder SAS nor Energizer Brands, LLC is affiliated with the respective owners of their trademarks.

Let's get started.

You're excited to power up, so we'll keep this brief!

CONTENTS

1. SAFETY PRECAUTIONS	5
2. INSTRUCTIONS FOR SERVICING	13
3. NAMES OF PARTS	19
4. INDOOR UNIT DISPLAY	20
5. EMERGENCY FUNCTION & AUTO-RESTART FUNCTION	20
6. REMOTE CONTROL	21
7. OPERATING INSTRUCTIONS	30
8. INSTALLATION MANUAL-IMPORTANT CONSIDERATIONS	31
9. INSTALLATION MANUAL-SELECTING THE INSTALLATION PLACE	34
10. INSTALLATION MANUAL-INSTALLATION OF THE INDOOR UNIT	35
11. INSTALLATION MANUAL-INSTALLATION OF THE OUTDOOR UNIT	39
12. INSTALLATION MANUAL-OPERATION TEST	41
13. INSTALLATION MANUAL-INFORMATION FOR THE INSTALLER	41
14. MAINTENANCE	44
15. TROUBLESHOOTING	45
16. DISPOSAL	46
17. WARRANTY	47
18. PRODUCT FAILURE	48
19. WARRANTY EXCLUSIONS	49





THE APPLIANCE IS IN CONFORMITY WITH EUROPEAN DIRECTIVE 2014/30/EU FOR EMC 2014/35/EU FOR LVD, 2009/125/EC FOR ERP AND 2011/65/EU FOR ROHS, AND COMPLY WITH THE RELEVANT STANDARDS.

1. SAFETY PRECAUTIONS

1.1 SAFETY RULES AND RECOMMENDATIONS FOR THE INSTALLER

 Read this guide before installing and using the appliance.

 During the installation of the indoor and outdoor units, access to the working area should be forbidden to children. Unforeseeable accidents could happen.

 Make sure that the base of the outdoor unit is firmly fixed.

 Check that air cannot enter the refrigerant system and check for refrigerant leaks when moving the air conditioner.

 Carry out a test cycle after installing the air conditioner and record the operating data.

 The ratings of the fuse installed in the built in control unit are 4A /250V.

 Protect the indoor unit with a fuse of suitable capacity for the maximum input current or with another overload protection device.

 Check that the socket is suitable for the plug, otherwise have the socket changed.

 The appliance must be fitted with means for disconnection from the supply mains having a contact separation in all poles that provide full disconnection under over voltage category III conditions, and these means must be incorporated in the fixed wiring in accordance with the wiring rules.

 The air conditioner must be installed by professional or qualified persons.

 Do not install the appliance at a distance of less than 50 cm from inflammable substances (alcohol, etc.) or from pressurised containers (e.g. spray cans).

 If the appliance is used in areas without the possibility of ventilation, precautions must be taken to prevent any leaks of refrigerant gas from remaining in the environment and creating a danger of fire.

 The packaging materials are recyclable and should be disposed of in the separate waste bins. Take the air conditioner at the end of its useful life to a special waste collection centre for disposal.

 Only use the air conditioner as instructed in this booklet. These instructions are not intended to cover every possible condition and situation. As with any electrical household appliance, common sense and caution are therefore always recommended for installation, operation and maintenance.

 The appliance must be installed in accordance with applicable national regulations.

 Before accessing the terminals, all the power circuits must be disconnected from the power supply.

 The appliance shall be installed in accordance with national wiring regulations.

 This appliance can be used by children aged from 8 years and above and persons with reduced physical, sensory or mental capabilities or lack of experience and knowledge. Only if they have been given supervision or instruction concerning use of the appliance in a safe way and understand the hazards involved. Children shall not play with the appliance. Cleaning and user maintenance shall not be made by children without supervision.

1.2 SAFETY RULES AND RECOMMENDATIONS

FOR THE USER

 Do not try to install the conditioner alone; always contact specialized technical personnel.

 Cleaning and maintenance must be carried out by specialized technical personnel. In any case, disconnect the appliance from the mains electricity supply before carrying out any cleaning or maintenance.

 Ensure that the mains voltage corresponds to that stamped on the rating plate. Keep the switch or power plug clean. Insert the power plug correctly and firmly into the socket, thereby avoiding the risk of electric shock or fire due to insufficient contact.

 Do not pull out the plug to switch off the appliance when it is in operation, since this could create a spark and cause a fire, etc.

 This appliance has been made for air conditioning domestic environments and must not be used for any other purpose, such as for drying clothes, cooling food, etc.

 The packaging materials are recyclable and should be disposed of in the separate waste bins. Take the air conditioner at the end of its useful life to a special waste

collection center for disposal.

 Always use the appliance with the air filter mounted.

The use of the conditioner without an air filter could cause an excessive accumulation of dust or waste on the inner parts of the device with possible subsequent failures.

 The user is responsible for having the appliance installed by a qualified technician, who must check that it is earthed in accordance with current legislation and insert a thermomagnetic circuit breaker.

 The batteries in the remote controller must be recycled or disposed of properly. For disposal of scrap batteries, please discard the batteries as sorted municipal waste at the accessible collection point.

 Never remain directly exposed to the flow of cold air for a long time. The direct and prolonged exposure to cold air could be dangerous for your health. Particular care should be taken in the rooms where there are children, old or sick people.

 If the appliance gives off smoke or there is a smell of burning, immediately cut off the power supply and contact the Service Centre.

 The prolonged use of the device in such conditions could cause fire or electrocution.

 Have repairs carried out only by an authorised Service Centre of the manufacturer. Incorrect repair could expose the user to the risk of electric shock, etc.

 Unhook the automatic switch if you will not be using the device for a long time. The airflow direction must be properly adjusted.

 The flaps must be directed downwards in the heating mode and upwards in the cooling mode.

 Only use the air conditioner as instructed in this booklet. These instructions are not intended to cover every possible condition and situation. As with any electrical household appliance, common sense and caution are therefore always recommended for installation, operation and maintenance.

 Ensure that the appliance is disconnected from the power supply when it will remain inoperative for a long period and before carrying out any cleaning or maintenance.

 Selecting the most suitable temperature can prevent damage to the appliance.

1.3 SAFETY RULES AND PROHIBITIONS

- ⊖ Do not bend, tug or compress the power cord since this could damage it. Electrical shocks or fire are probable due to a damaged power cord. Specialized technical personnel only must replace a damaged power cord.
- ⊖ Do not use extensions or gang modules.
- ⊖ Do not touch the appliance when barefoot or parts of the body are wet or damp.
- ⊖ Do not obstruct the air inlet or outlet of the indoor or the outdoor unit. The obstruction of these openings causes a reduction in the operative efficiency of the conditioner with possible consequential failures or damages. In no way alter the characteristics of the appliance.
- ⊖ Do not install the appliance in environments where the air could contain gas, oil or sulphur or near sources of heat.
- ⊖ This appliance is not intended for use by persons (including children) with reduced physical, sensory or mental capabilities, or lack of experience and knowledge, unless they have been given supervision or instruction concerning use of the appliance by a person responsible.

- ⊖ Do not climb onto or place any heavy or hot objects on top of the appliance.
- ⊖ Do not leave windows or doors open for long periods of time when the air conditioner is operating.
- ⊖ Do not direct the airflow onto plants or animals.
- ⊖ A long direct exposure to the flow of cold air of the conditioner could have negative effects on plants and animals.
- ⊖ Do not put the conditioner in contact with water. The electrical insulation could be damaged and thus causing electrocution.
- ⊖ Do not climb onto or place any objects on the outdoor unit.
- ⊖ Never insert a stick or similar object into the appliance. It could cause injury. Children should be supervised to ensure that they do not play with the appliance. If the supply cord is damaged, it must be replaced by the manufacturer, its service agent or similarly qualified persons in order to avoid a hazard.

2. INSTRUCTIONS FOR SERVICING

1. Check the information in this manual to find out the dimensions of space needed for proper installation of the device, including the minimum distances allowed compared to adjacent structures.
2. Appliance shall be installed, operated and stored in a room with a floor area larger than 4m².
3. The installation of pipe-work shall be kept to a minimum.
4. The pipe-work shall be protected from physical damage, and shall not be installed in an unventilated space if the space is smaller than 4m².
5. The compliance with national gas regulations shall be observed.
6. The mechanical connections shall be accessible for maintenance purposes.
7. Follow the instructions given in this manual for handling, installing, cleaning, maintaining and disposing of the refrigerant.
8. Make sure ventilation openings are clear of obstruction.
9. Notice: the servicing shall be performed only as recommended by the manufacturer.
10. **Warning:** the appliance shall be stored in a well-ventilated area where the room size corresponds to the room area as specified for operation.
11. **Warning:** the appliance shall be stored in a room without continuously operating open flames (for example an operating gas appliance) and ignition sources (for example an operating electric heater).
12. The appliance shall be stored so as to prevent mechanical damage from occurring.
13. It is appropriate that anyone who is called upon to work on a refrigerant circuit should hold a valid and up-to-date certificate from an assessment authority accredited by the industry and recognizing their competence to handle refrigerants, in accordance with the assessment specification recognized in the industrial sector concerned. Service operations should only be carried out in accordance with the recommendations of the equipment manufacturer. Maintenance and repair operations that require the assistance of other qualified persons must be conducted under the supervision of the person competent for the use of flammable refrigerants.
14. Every working procedure that affects safety means shall only be carried out by competent persons.
15. **Warning:**
 - ❖ *Do not use means to accelerate the defrosting process or to clean, other than those recommended by the manufacturer.*
 - ❖ *The appliance shall be stored in a room without continuously operating ignition sources (for example: open flames, an operating gas appliance or an operating electric heater).*
 - ❖ *Do not pierce or burn.*
 - ❖ **Be aware that refrigerants may not contain an odour.*



Caution: Risk of fire



Operating instructions



Read technical manual

16. Information on servicing:

- 1) Checks to the area: Prior to beginning work on systems containing flammable refrigerants, safety checks are necessary to ensure that the risk of ignition is minimized. For repair to the refrigerating system, the following precautions shall be complied with prior to conducting work on the system.
- 2) Work procedure: Work shall be undertaken under a controlled procedure so as to minimize the risk of a flammable gas or vapour being present while the work is being performed.
- 3) General work area: All maintenance staff and others working in the local area shall be instructed on the nature of work being carried out. Work in confined spaces shall be avoided. The area around the workspace shall be sectioned off. Ensure that the conditions within the area have been made safe by control of flammable material.
- 4) Checking for presence of refrigerant: The area shall be checked with an appropriate refrigerant detector prior to and during work, to ensure the technician is aware of potentially flammable atmospheres. Ensure that the leak detection equipment being used is suitable for use with flammable refrigerants, i.e. non-sparking, adequately sealed or intrinsically safe.
- 5) Presence of fire extinguisher: If any hot work is to be conducted on the refrigeration equipment or any associated parts, appropriate fire extinguishing equipment shall be available to hand. Have a dry powder or Co2 fire extinguisher adjacent to the charging area.
- 6) No ignition sources: No person carrying out work in relation to a refrigeration system which involves exposing any pipe work shall use any sources of ignition in such a manner that it may lead to the risk of fire or explosion. All possible ignition sources, including cigarette smoking, should be kept sufficiently far away from the site of installation, repairing, removing and disposal, during which refrigerant can possibly be released to the surrounding space. Prior to work taking place, the area around the equipment is to be surveyed to make sure that there are no flammable hazards or ignition risks. No Smoking signs shall be displayed.
- 7) Ventilated area: Ensure that the area is in the open or that it is adequately ventilated before breaking into the system or conducting any hot work. A degree of ventilation shall continue during the period that the work is carried out. The ventilation should safely disperse any released refrigerant and preferably expel it externally into the atmosphere.
- 8) Checks to the refrigeration equipment: Where electrical components are being changed, they shall be fit for the purpose and to the correct specification. At all times the manufacturer's maintenance and service guidelines shall be followed. If in doubt consult the manufacturer's technical department for assistance.

The following checks shall be applied to installations using flammable refrigerants:

- The charge size is in accordance with the room size within which the refrigerant containing parts are installed;
- The ventilation machinery and outlets are operating adequately and are not obstructed;
- If an indirect refrigerating circuit is being used, the secondary circuit shall be checked for the presence of refrigerant;
- Marking to the equipment continues to be visible and legible. Markings and signs that are

illegible shall be corrected;

- Refrigeration pipe or components are installed in a position where they are unlikely to be exposed to any substance which may corrode refrigerant containing components, unless the components are constructed of materials which are inherently resistant to being corroded or are suitably protected against being so corroded.
- 9) Checks to electrical devices: Repair and maintenance to electrical components shall include initial safety checks and component inspection procedures. If a fault exists that could compromise safety, then no electrical supply shall be connected to the circuit until it is satisfactorily dealt with. If the fault cannot be corrected immediately but it is necessary to continue operation, an adequate temporary solution shall be used.

This shall be reported to the owner of the equipment so all parties are advised.

Initial safety checks shall include:

- That capacitors are discharged: this shall be done in a safe manner to avoid possibility of sparking;
- That there no live electrical components and wiring are exposed while charging, recovering or purging the system;
- That there is continuity of earth bonding.

17. Repairs to sealed components:

- 1) During repairs to sealed components, all electrical supplies shall be disconnected from the equipment being worked upon prior to any removal of sealed covers, etc. If it is absolutely necessary to have an electrical supply to equipment during servicing, then a permanently operating form of leak detection shall be located at the most critical point to warn of a potentially hazardous situation.
- 2) Particular attention shall be paid to the following to ensure that by working on electrical components, the casing is not altered in such a way that the level of protection is affected. This shall include damage to cables, excessive number of connections, terminals not made to original specification, damage to seals, incorrect fitting of glands, etc.
- 3) Ensure that apparatus is mounted securely.
- 4) Ensure that seals or sealing materials have not degraded such that they no longer serve the purpose of preventing the ingress of flammable atmospheres. Replacement parts shall be in accordance with the manufacturer's specifications.

NOTE: The use of silicon sealant may inhibit the effectiveness of some types of leak detection equipment. Intrinsically safe components do not have to be isolated prior to working on them.

18. Repair to intrinsically safe components:

- 1) Do not apply any permanent inductive or capacitance loads to the circuit without ensuring that this will not exceed the permissible voltage and current permitted for the equipment in use. Intrinsically safe components are the only types that can be worked on while live in the presence of a flammable atmosphere. The test apparatus shall be at the correct rating.

- 2) Replace components only with parts specified by the manufacturer. Other parts may result in the ignition of refrigerant in the atmosphere from a leak.

19. Cabling

Check that cabling will not be subject to wear, corrosion, excessive pressure, vibration, sharp edges or any other adverse environmental effects. The check shall also take into account the effects of aging or continual vibration from sources such as compressors or fans.

20. Detection of flammable refrigerants

Under no circumstances shall potential sources of ignition be used in the searching for or detection of refrigerant leaks. A halide torch (or any other detector using a naked flame) shall not be used.

21. Leak detection methods

The following leak detection methods are deemed acceptable for systems containing flammable refrigerants.

Electronic leak detectors shall be used to detect flammable refrigerants, but the sensitivity may not be adequate, or may need re-calibration. (Detection equipment shall be calibrated in a refrigerant-free area).

Ensure that the detector is not a potential source of ignition and is suitable for the refrigerant used. Leak detection equipment shall be set at a percentage of the LFL of the refrigerant and shall be calibrated to the refrigerant employed and the appropriate percentage of gas (25 % maximum) is confirmed.

Leak detection fluids are suitable for use with most refrigerants but the use of detergents containing chlorine shall be avoided as the chlorine may react with the refrigerant and corrode the copper pipe-work.

If a leak is suspected, all naked flames shall be removed/ extinguished.

If a leakage of refrigerant is found which requires brazing, all of the refrigerant shall be recovered from the system, or isolated (by means of shut off valves) in a part of the system remote from the leak. Oxygen free nitrogen (OFN) shall then be purged through the system both before and during the brazing process.

22. Removal and evacuation

When breaking into the refrigerant circuit to make repairs or for any other purpose conventional procedures shall be used. However, it is important that best practice is followed since flammability is a consideration. The following procedure shall be adhered to:

- Remove refrigerant;
- Purge the circuit with inert gas;
- Evacuate;
- Purge again with inert gas;
- Open the circuit by cutting or brazing.

The refrigerant charge shall be recovered into the correct recovery cylinders. The system shall be flushed with OFN to render the unit safe. This process may need to be repeated several times. Compressed air or oxygen shall not be used for this task.

Flushing shall be achieved by breaking the vacuum in the system with OFN and continuing to fill until the working pressure is achieved, then venting to atmosphere, and finally pulling down to a vacuum. This process shall be repeated until no refrigerant is within the system. When the final OFN charge is used, the system shall be vented down to atmospheric pressure to enable work to take place. This operation is absolutely vital if brazing operations on the pipe-work are to take place.

Ensure that the outlet for the vacuum pump is not close to any ignition sources and there is ventilation available.

23. Decommissioning

Before carrying out this procedure, it is essential that the technician is completely familiar with the equipment and all its detail. It is recommended good practice that all refrigerants are recovered safely. Prior to the task being carried out, an oil and refrigerant sample shall be taken in case analysis is required prior to re-use of reclaimed refrigerant. It is essential that electrical power is available before the task is commenced.

- 1) Become familiar with the equipment and its operation.
- 2) Isolate system electrically.
- 3) Before attempting the procedure, ensure that:
 - Mechanical handling equipment is available, if required, for handling refrigerant cylinders;
 - All personal protective equipment is available and being used correctly;
 - The recovery process is supervised at all times by a competent person;
 - Recovery equipment and cylinders conform to the appropriate standards.
- 4) Pump down refrigerant system, if possible.
- 5) If a vacuum is not possible, make a manifold so that refrigerant can be removed from various parts of the system.
- 6) Make sure the cylinder is situated on the scales before recovery takes place.
- 7) Start the recovery machine and operate in accordance with manufacturer's instructions.
- 8) Do not overfill cylinders. (No more than 80% volume liquid charge).
- 9) Do not exceed the maximum working pressure of the cylinder, even temporarily.
- 10) When the cylinders have been filled correctly and the process completed, make sure that the cylinders and the equipment are removed from site promptly and all isolation valves on the equipment are closed off.
- 11) Recovered refrigerant shall not be charged into another refrigeration system unless it has been cleaned and checked.

24. Labelling

Equipment shall be labelled stating that it has been de-commissioned and emptied of refrigerant. The label shall be dated and signed. Ensure that there are labels on the equipment stating the

equipment contains flammable refrigerant.

25. Charging procedures

In addition to conventional charging procedures, the following requirements shall be followed.

- Ensure that contamination of different refrigerants does not occur when using charging equipment. Hoses or lines shall be as short as possible to minimise the amount of refrigerant contained in them.
- Cylinders shall be kept upright.
- Ensure that the refrigeration system is earthed prior to charging the system with refrigerant.
- Label the system when charging is complete (if not already).
- Extreme care shall be taken not to overfill the refrigeration system.

Prior to recharging the system, it shall be pressure-tested with the appropriate purging gas.

The system shall be leak-tested on completion of charging but prior to commissioning. A follow up leak test shall be carried out prior to leaving the site.

26. Recovery

When removing refrigerant from a system, either for servicing or decommissioning, it is recommended good practice that all refrigerants are removed safely.

When transferring refrigerant into cylinders, ensure that only appropriate refrigerant recovery cylinders are employed. Ensure that the correct number of cylinders for holding the total system charge are available. All cylinders to be used are designated for the recovered refrigerant and labelled for that refrigerant (i.e. special cylinders for the recovery of refrigerant).

Cylinders shall be complete with pressure-relief valve and associated shut-off valves in good working order. Empty recovery cylinders are evacuated and, if possible, cooled before recovery occurs.

The recovery equipment shall be in good working order with a set of instructions concerning the equipment that is at hand and shall be suitable for the recovery of all appropriate refrigerants including, when applicable, flammable refrigerants. In addition, a set of calibrated weighing scales shall be available and in good working order. Hoses shall be complete with leak-free disconnect couplings and in good condition. Before using the recovery machine, check that it is in satisfactory working order, has been properly maintained and that any associated electrical components are sealed to prevent ignition in the event of a refrigerant release. Consult manufacturer if in doubt. The recovered refrigerant shall be returned to the refrigerant supplier in the correct recover cylinder, and the relevant waste transfer note arranged. Do not mix refrigerants in recovery units and especially not in cylinders.

If compressors or compressor oils are to be removed, ensure that they have been evacuated to an acceptable level to make certain that flammable refrigerant does not remain within the lubricant.

The evacuation process shall be carried out prior to returning the compressor to the suppliers.

Only electric heating to the compressor body shall be employed to accelerate this process. When oil is drained from a system, it shall be carried out safely.

3. NAMES OF PARTS

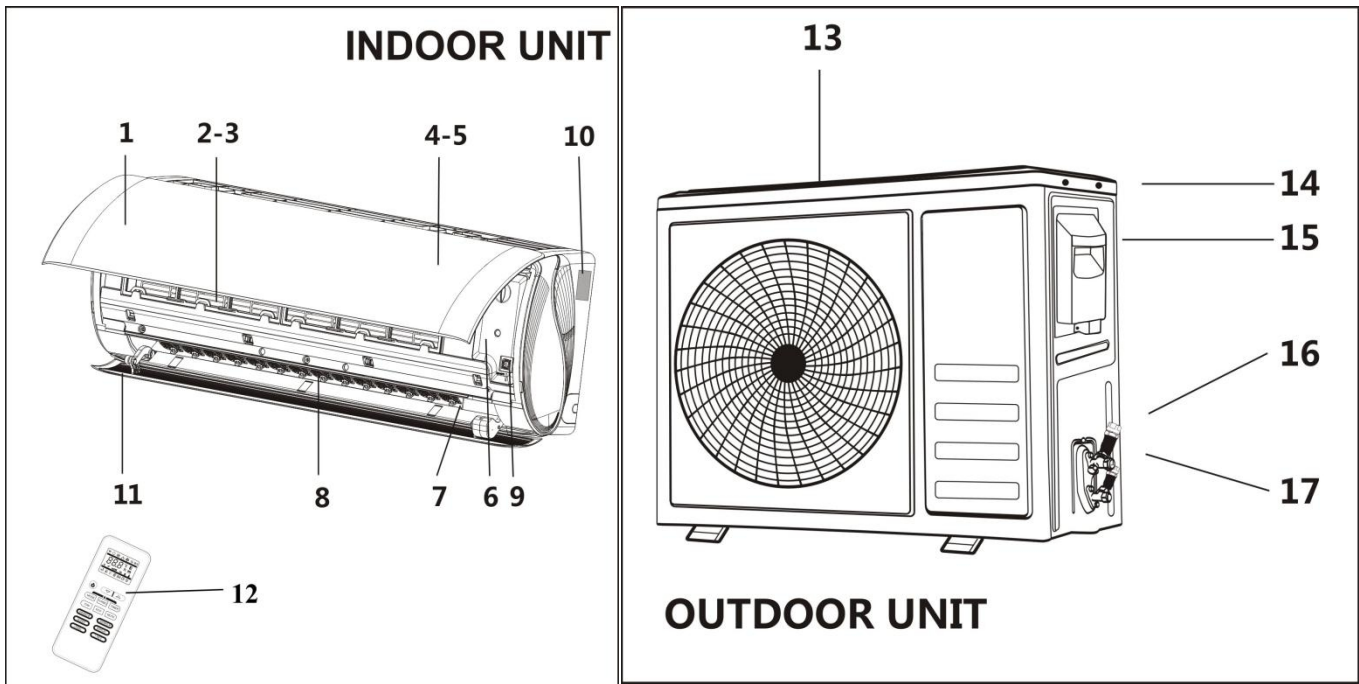



Note: The above figures are only intended to be a simple diagram of the appliance and may not correspond to the appearance of the units that have been purchased.

1. Front panel
2. Air filter
3. Optional filter (if installed)
4. LED Display
5. Signal receiver
6. Terminal block cover
7. Ionizer generator (if installed)
8. Deflectors
9. Emergency button
10. Indoor unit rating label (Sticker position optional)
11. Airflow direction louver
12. Remote controller
13. Air outlet grille
14. Outdoor unit rating label
15. Terminal block cover
16. Gas valve
17. Liquid valve

4. INDOOR UNIT DISPLAY



No.	Led		Function
1	SLEEP		SLEEP mode
2	Temperature display (if present) /Error code		(1) Lights up during Timer operation when the air conditioner is operational (2) Displays the malfunction code when fault occurs.
3	TIMER		Lights up during Timer operation.



The shape and position of switches and indicators may be different according to the model, but their function is the same.

5. EMERGENCY FUNCTION & AUTO-RESTART FUNCTION

5.1 EMERGENCY FUNCTION

If the remote controller fails to work or maintenance is necessary, proceed as following:

- Open and lift the front panel up to an angle to reach the emergency button.
- For heating model, press the emergency button the first time, the unit will operate in COOL mode. Press a second time within 3 seconds, the unit will operate in HEAT mode. Press the third time after 5 seconds, the unit will turn off.
- For cooling only model, press the emergency button the first time, the unit will operate in COOL mode.
- Press again, the unit will turn off.

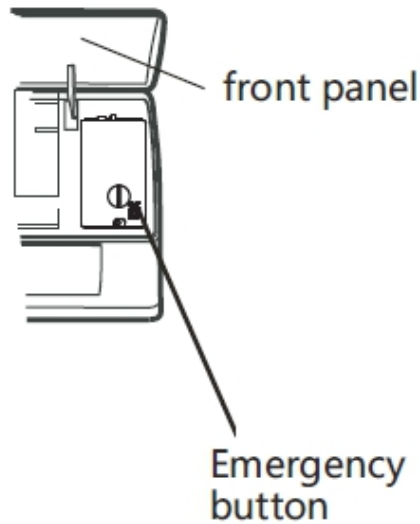

The emergency button is located on E-box cover of the unit under the front panel.

5.2 AUTO-RESTART FUNCTION

The appliance is preset with an auto-restart function.

In case of a sudden power failure, the module will memorize the setting conditions before the power failure. When the power restores, the unit will restart automatically with the previous settings preserved by the memory function.







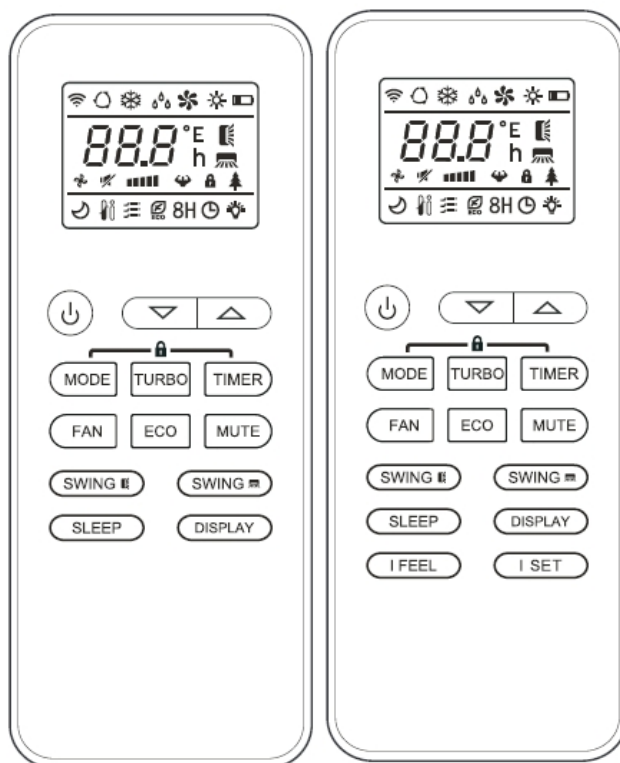











The shape and position of the emergency button may be different according to the model, but their function is the same.





6. REMOTE CONTROL



The display and some functions of the remote control may vary according to the model.

6.1 REMOTE CONTROL DISPLAY

No.	Symbol	Meaning
1		Battery indicator
2		Auto Mode
3		Cooling Mode
4		Dry Mode
5		Fan only Mode
6		Heating Mode
7		ECO Mode
8		Timer
9		Temperature indicator
10		Fan speed: Auto/ low/ low-mid/ mid/ mid-high/ high
11		Mute function
12		TURBO function
13		Up-down auto swing
14		Left-right auto swing
15		SLEEP function
16		Health function
17		I FEEL function
18		8°C heating function
19		Signal indicator
20		Gentle wind
21		Child-Lock
22		Display ON/OFF

No.	Button	Function
1		To turn on/off the air conditioner.
2	^	To decrease temperature, or Timer setting hours.
3	v	To increase temperature, or Timer setting hours.
4	MODEL	To select the mode of operation (AUTO, COOL, DRY, FAN, HEAT).
5	ECO	To activate/deactivate the ECO function. Long press to activate/deactivate the 8 heating function (depending on models).
6	TURBO	To activate/deactivate the TURBO function.
7	FAN	To select the fan speed of auto/low/mid/high.
8	TIMER	To set the time for timer on/off.
9	SLEEP	To switch-on/off the function SLEEP.
10	DISPLAY	To switch-on/off the LED display.
11	SWING  	To stop or start horizontal louver movement or set the desired up/down air flow direction.
12	SWING < >	To stop or start horizontal louver movement or set the desired left/right air flow direction.
13	I FEEL	To switch-on/off the I FEEL function.
14	MUTE	To switch-on/off the MUTE function. Long press to activate/deactivate the GEN function (depending on models).
15	MODE +TIMER	To activate/deactivate the CHILD-LOCK function.
16	SWING   SWING < >	To activate/deactivate the SELF-CLEAN function (depending on models).
17	FAN + MUTE	To activate/deactivate the GENTLE WIND function (depending on models).
18	SLEEP +DISPLAY	To activate/deactivate the HEALTH function (depending on models).
19	I SET	To memorize the setting temperature, setting mode and setting fan speed as you need.



The display and some functions of the remote control may vary according to the model.



The shape and position of buttons and indicators may vary according to the model, but their function is the same.



The unit confirms the correct reception of each button with the beep.

6.2 REPLACEMENT OF BATTERIES

- 1) Remove the battery cover plate from the rear of the remote control, by sliding it in the same direction as the arrow.
- 2) Install the batteries according to the direction (+ and -) shown on the Remote Control.
- 3) Reinstall the battery cover by sliding it into place.



Use 2 pieces LRO3 AAA (1.5V) batteries.

Do not use rechargeable batteries.

Replace the old batteries with new ones of the same type when the display is no longer legible.

Do not dispose batteries as unsorted municipal waste.

Collection of such waste separately for special treatment is necessary.

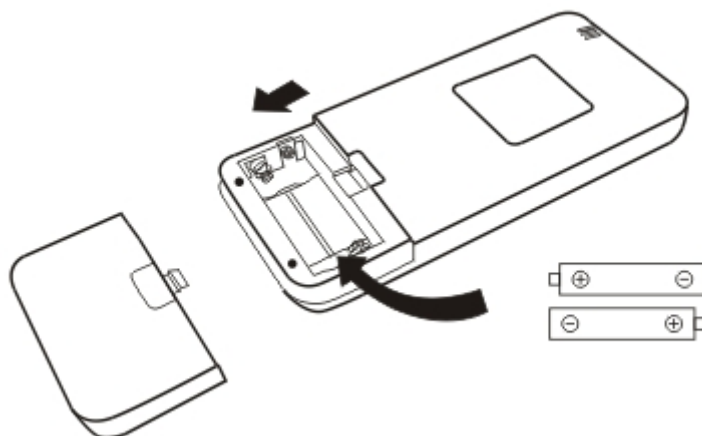

For some models, each time you insert the batteries in the remote controller for the first time, you can set the Cooling only or Heating pump control type. As soon as you insert the batteries, turn off the remote controller, and operate as below.

1. Long press the **MODE** button, until the () icon flash, to set the Cooling only type.

2. Long press the **MODE** button, until the () icon flash, to set the Heating pump type.

Note: If you set the remote control in cooling mode, it will not be possible to activate the heating function in units with a heating pump. If you need to reset, take out the batteries and install again.



For some models of the remote controller, you can program the temperature display between °C and °F.

1. Press and hold the **TURBO** button over 5 seconds to get into the change mode;

2. Press and hold the **TURBO** button, until it switches to °C and °F;

3. Then release the pressing and wait for 5 seconds, the function will be selected.

Note:

1. Direct the remote control toward the air conditioner.

2. Check that there are no objects between the remote control and the signal receptor in the indoor unit.

3. Never leave the remote control exposed to the rays of the sun.

4. Keep the remote control at a distance of at least 1m from the television or other electrical appliances.

6.3 COOLING MODE

COOL 

The cooling function allows the air conditioner to cool the room and reduce air humidity at the same time. To activate the cooling function (**COOL**), press the **MODE** button until the

symbol  appears on the display.

With the button  or  set a temperature lower than that of the room.

6.4 FAN MODE (Not FAN button)



Fan mode, air ventilation only. To set the **FAN** mode, press the **MODE** button until



appears on the display.

6.5 DRY MODE



This function reduces the humidity of the air to make the room more comfortable.

To set the DRY mode, press the **MODE** button until  appears in the display. An automatic function of pre-setting is activated.

6.5 AUTO MODE



Automatic mode.

To set the AUTO mode, press MODE until  appears on the display. In AUTO mode the run mode will be set automatically according to the room temperature.

6.6 HEATING MODE



The heating function allows the air conditioner to heat the room.

To activate the heating function (**HEAT**), press the **MODE** button until the symbol  appears on the display.

With the button  or  set a temperature higher than that of the room.



In **HEATING** operation, the appliance can automatically activate a defrost cycle, which is essential to clean the frost on the condenser so as to recover its heat exchange function. This procedure usually lasts for 2-10 minutes. During defrosting, the indoor unit fan will stop operation. After defrosting, it resumes to **HEATING** mode automatically.



(For North American market) If necessary, you can press **ECO** button 10 times within 8 seconds under heating mode to start the forced defrosting. It will defrost the outdoor ice much **faster**.

6.7 FAN SPEED FUNCTION (FAN BUTTON)



Change the operating fan speed. Press **FAN** button to set the running fan speed, it can be set to AUTO/ MUTE/ LOW/ LOW-MID/ MID/ MID-HIGH/ HIGH/ TURBO speed circularly.

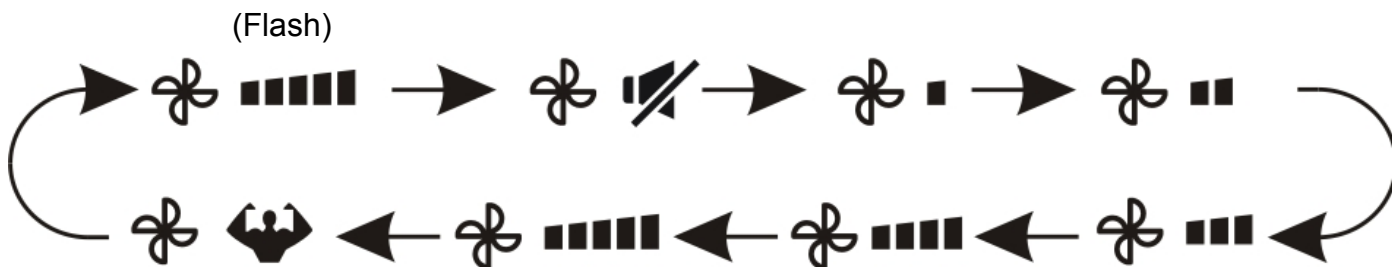

6.8 CHILD-LOCK FUNCTION







- 1) Long press **MODE** and **TIMER** button together to activate this function, and do it again to deactivate this function.
- 2) Under this function, no single button will activate.

6.7 TIMER FUNCTION - TIMER ON

TIMER 

To start-up the appliance.

When the unit is turned off, you can set the **TIMER ON**. To set the time of automatic start-up below:

- 1) Press **TIMER** button the first time to set the start time,  and  will appear on the remote display and flashes.
- 2) Press  or  button to set desired Timer-on time. Each time you press the button, the time increases/decreases by half an hour between 0 and 10 hours and by one between 10 and 24 hours.
- 3) Press **TIMER** button a second time to confirm.
- 4) After Timer-on setting, set the needed mode (Cool/ Heat/ Auto/ Fan/ Dry), by pressing the **MODE** button. Set the needed fan speed, by pressing **FAN** button. And press  or  to set the needed operation temperature.
- 5) CANCEL it by pressing **TIMER** button.



6.8 TIMER FUNCTION - TIMER OFF

TIMER 

To automatically shutdown the appliance.

When the unit is running, you can set the **TIMER OFF**.

To set the time of automatic shutdown, see below:



- 1) Confirm the appliance is ON.
- 2) Press **TIMER** button the first time to set the shutdown time. Press  or  to set the needed timer.
- 3) Press **TIMER** button a second time to confirm.
- 4) CANCEL it by pressing **TIMER** button.



Note: All programming should be operated within 5 seconds, otherwise the setting will be cancelled.

6.9 SWING FUNCTION



1. Press the button **SWING** to activate the louver.

1) Press  to activate the horizontal flaps to swing from up to down, the  will appear on the remote display. Press again to stop the swing movement at the current angle.

2) Press  to active the vertical deflectors to swing from left to right, the  will appear on the remote display. Press again to stop the swing movement at the current angle.

3) For some inverter heating models, press the horizontal and vertical **SWING** buttons together at the same time, it will activate the Self-Clean function.



This adjustment must be done while the appliance is switched off.



Never position “Flaps” manually, the delicate mechanism might become seriously damaged!



Never put fingers, sticks or other objects into the air inlet or outlet vents. Such accidental contact with live parts might cause unforeseeable damage or injury.

6.10 TURBO FUNCTION



To activate turbo function, press the **TURBO** button, and  will appear on the display. Press again to cancel this function.

In COOL/ HEAT mode, when you select **TURBO** feature, the appliance will turn to quick COOL or quick HEAT mode, and operate the highest fan speed to blow strong airflow.

6.11 MUTE FUNCTION



1. Press MUTE button to active this function, and  will appears on the remote display. Do it again to deactivate this function.

2. When the **MUTE** function runs, the remote controller will display the auto fan speed, and the indoor unit will operate at lowest fan speed to be quiet.

3. When pressing FAN/ TURBO/ SLEEP button, the **MUTE** function will be cancel. **MUTE** function can not be activated under dry mode.

6.12 SLEEP FUNCTION



Pre-setting automatic operating program.

Press **SLEEP** button to activate the **SLEEP** function, and  appears on the display. Press again to cancel this function. After 10 hours running in sleep mode, the air conditioner will change to the previous setting mode.

6.13 I FEEL FUNCTION (OPTIONAL)



Press **I FEEL** button to activate the function, the  will appear on the remote display. Do it again to deactivate this function.

This function enables the remote control to measure the temperature at its current location, and send this signal to the air conditioner to optimize the temperature around you and ensure comfort.

It will automatically deactivate 2 hours later.

6.14 ECO FUNCTION



In this mode the appliance automatically sets the operation to save energy.

Press the **ECO** button, the  appears on the display, and the appliance will run in ECO mode. Press again to cancel it.

Note: The **ECO** function is available in both **COOLING** and **HEATING** modes.

6.15 DISPLAY FUNCTION (INDOOR DISPLAY)



Switch ON/OFF the LED display on panel.



Press **DISPLAY** button to switch off the LED display on the panel. Press again to switch on the LED display.

6.16 GEN FUNCTION (OPTIONAL)

1. Turn on the indoor unit at first, and long press **MUTE** button 3 seconds to active, and do it again to deactivate this function.
2. Under this function, short press **MUTE** button to select the General type L3 - L2 - L1 - OFF.
3. Select OFF and wait 2 seconds to exit.

6.17 SELF-CLEAN FUNCTION (OPTIONAL)

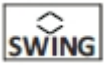
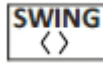
Only optional for some heating pump inverter appliance.

To activate this function, turn off the indoor unit first, then press  and  button at the same time toward the indoor unit, until you hear a beep, and  will appear on the remote controller display and the indoor LED display.

1. This function helps carry away the accumulated dirt, bacteria, etc. from the indoor evaporator.
2. This function will run about 30 minutes, and it will return to the pre-setting mode. You can press

 button to cancel this function during the process.

You will hear 2 beeps when it's finished or cancelled.



 It's normal if there is some noise during this function process, as plastic materials expand with heat and contract with cold.

 We suggest operating this function at the following ambient conditions to avoid certain safety protection features.

Indoor unit	Temp < 86 °F (30 °C)
Outdoor unit	41°F (5°C) < Temp < 86°F (30°C)

 It's suggested to utilize this function every 3 months.

6.18 8°C HEATING FUNCTION (OPTIONAL)

1. Long press **ECO** button over 3 seconds to active this function, and  () will appear on the remote display.

Do it again to deactivate this function.

2. This function will auto start the heating mode when the room temperature is lower than 8°C (46°F), and it will return to standby if the temperature reaches 9°C (48°F).

3. If the room temperature is higher than 18°C (64°F), the appliance will cancel this function automatically.

6.19 GENTLE WIND FUNCTION (OPTIONAL)

1. Turn on the indoor unit, and change to **COOL** mode, then long press **FAN** and **MUTE** button together 3 seconds to activate this function,  will appear on the display.

Do it again to deactivate it.

2. This function will auto close the vertical flaps, and give you the comfortable gentle wind feeling.

6.20 HEALTH FUNCTION (OPTIONAL)

1. Turn on the indoor unit first, and long press **SLEEP** and **DISPLAY** button together 3 seconds to active this function, will appear on the display. Do it again to deactivate it.

2. When the **HEALTH** function is initiated, the Ionizer/ Plasma/ Bipolar Ionizer/ UVC Lights (depending on models) will be energized and running.

6.21 I SET FUNCTION (OPTIONAL)

Remember your favorite setting and run remove into it by pressing one button

Remember the favorite setting:

1. In each mode (COOLING/ HEATING/ FAN/ DRY), long press " **I SET** " button over 3 seconds to remember it;

2. When "**AU**" flashes on the remote controller display, that means the remote controller remembers your favorite setting;

* Press any button to quit, and you can reset it by repeat steps 1 and 2 operation.

Running your favorite setting:

1. In each mode (COOLING/ HEATING/ FAN/ DRY), one press " **I SET** " button to activate;

2. The appliance will run your favorite setting and you will see **[AU]** flashing on the remote controller;

3. Press it again or other buttons to cancel this function.

7. OPERATING INSTRUCTIONS

Operating Temperature

The air conditioner is programmed for comfortable and suitable living conditions as below, If used outside the conditions, certain safety protection features might come into effect. Fix air conditioner:

MODE Temperature	Cooling operating	Heating operating	Drying operating
Room temperature	17°C ~32°C	0°C ~27°C	17°C ~32°C
Outdoor temperature	15°C ~43°C For T1 Climate	-7°C ~24°C	15°C ~43°C For T1 Climate
	15°C ~52v For T3 Climate		15°C ~52°C For T3 Climate

Inverter air conditioner:

MODE Temperature	Cooling operating	Heating operating	Drying operating
Room temperature	17°C ~32°C	0°C ~30°C	17°C ~32°C
Outdoor temperature	15°C ~53°C For T1 Climate	-20°C ~30°C	15°C ~53°C For T1 Climate
	-15°C ~53°C For models with low temperature cooling system		-15°C ~53°C For models with low temperature cooling system

 The unit does not operate immediately if it is turned on after being turned off or after changing the mode during operation. This is a normal self-protection action, you need wait for about 3 minutes.

 The capacity and efficiency are according to the test conducted at full-load operation (the highest speed of indoor fan motor and the maximum open angle of the flaps and deflectors are requested).

8. INSTALLATION MANUAL - IMPORTANT

CONSIDERATIONS

Important Considerations

- The air conditioner you buy must be installed by professional personnel and the “Installation manual” is used only for the professional installation personnel! The installation specifications should be subject to our after-sale service regulations.
- When filling the combustible refrigerant, any rude operation may cause serious injury or injuries to human body or bodies and object or objects.
- A leak test must be done after the installation is completed.
- It is a must to do the safety inspection before maintaining or repairing an air conditioner using combustible refrigerant in order to ensure that the fire risk is reduced to minimum.
- It is necessary to operate the machine under a controlled procedure in order to ensure that any risk arising from the combustible gas or vapor during the operation is reduced to minimum.
- Requirements for the total weight of filled refrigerant and the area of a room to be equipped with an air conditioner (are shown as in the following Tables GG.1 and GG.2)



The maximum charge and the required minimum floor area

$$m_1 = (4m^3) \times \text{LFL}, m = (26m^3) \times \text{LFL}, m = (130m^3) \times \text{LFL}$$

Where LFL is the lower flammable limit in kg/m³, R290 LFL is 0.038 kg/m³, R32 LFL is 0.038kg/m³.

For the appliances with a charge amount $m_1 < M = m_2$

The maximum charge in a room shall be in accordance with the following:

$$m = 2.5 \times (\text{LFL})^{(5/4)} \times h_0 \max \times (A)^{1/2}$$

The required minimum floor area A_{\min} to install an appliance with refrigerant charge M (kg) shall be in accordance with following:

$$A_{\min} = (M / (2.5 \times (\text{LFL})^{(5/4)} \times h_0))^2$$

Where:

m_{\max} is the allowable maximum charge in a room, in kg;

M is the refrigerant charge amount in appliance, in kg;

A_{\min} is the required minimum room area, in m²;

A is the room area, in m ;

LFL is the lower flammable limit, in kg³/m ;

h_0 is the installation height of the appliance, in meters for calculating m_{\max} or A_{\min} ,

1.8 m for wall mounted;

Table GG.1 - Maximum charge (kg)

Category	LFL (kg/m ³)	h ₀ (m)	Floor area (m ²)						
			4	7	10	15	20	30	50
R290	0.038	0.6	0.05	0.07	0.08	0.1	0.11	0.14	0.18
		1	0.08	0.11	0.13	0.16	0.19	0.2	0.3
		1.8	0.15	0.2	0.24	0.29	0.34	0.41	0.53
		2.2	0.18	0.24	0.29	0.36	0.41	0.51	0.65
R32	0.306	0.6	0.68	0.9	1.08	0.32	1.53	1.87	2.41
		1	1.14	1.51	1.8	2.2	2.54	3.12	4.02
		1.8	2.05	2.71	3.24	3.97	4.58	5.61	7.254
		2.2	2.5	3.31	3.96	4.85	5.6	6.86	8.85

Table GG.2 - Minimum room area (m²)

Category	LFL (kg/m ³)	h ₀ (m)	Charge amount (M) (kg)						
			Minimum room area (m ²)						
R290	0.038		0.152kg	0.228kg	0.304kg	0.456kg	0.608kg	0.76kg	0.988kg
		0.6		82	146	328	584	912	1514
		1		30	53	118	210	328	555
		1.8		9	16	36	65	101	171
		2.2		6	11	24	43	68	115
R32	0.306		1.224kg	1.836kg	2.448kg	3.672kg	4.896kg	6.12kg	7.956kg
		0.6		29	51	116	206	321	543
		1		10	19	42	74	116	196
		1.8		3	6	13	23	36	60
		2.2		2	4	9	15	24	40

Installation Safety Principles

1. Site Safety



Open Flames Prohibited



Ventilation Necessary

2. Operation Safety



Mind Static Electricity/ Must wear protective clothing and anti-static gloves/ Don't use mobile phone

3. Installation Safety

- Refrigerant Leak Detector
- Appropriate Installation Location



Please note that:

1. The installation site should be in a well-ventilated area.
2. The sites for installing and maintaining an air conditioner using Refrigerant R290 should be free from open fire or welding, smoking, drying oven or any other heat source higher than 370°C which easily produces open fire; the sites for installing and maintaining an air conditioner using Refrigerant R32 should be free from open fire, welding, smoking, drying oven or any other heat source higher than 548°C which easily produces open fire.
3. When installing an air conditioner, it is necessary to take appropriate anti-static measures such as wearing anti-static clothing and/or gloves.
4. It is necessary to choose the site convenient for installation or maintenance wherein the air inlets and outlets of the indoor and outdoor units should not be surrounded by obstacles or close to any heat source or combustible and/or explosive environment.
5. If the indoor unit suffers a refrigerant leak during installation, it is necessary to immediately turn off the valve of the outdoor unit and all the personnel should go out until the refrigerant leak clears completely for 15 minutes. If the product is damaged, it is a must to carry such damaged product back to the maintenance station and it is prohibited to weld the refrigerant pipe or conduct other operations on the user's site.
6. It is necessary to choose the place where the inlet and outlet air of the indoor unit is even.
7. It is necessary to avoid the places where there are other electrical products, power switch plugs and sockets, kitchen cabinet, bed, sofa and other valuables right under the lines on two sides of the indoor unit.

Special Tools

Tool Name	Requirement(s) for Use
Mini Vacuum Pump	It should be an explosion-proof vacuum pump; can ensure certain precision and its vacuum degree should be lower than 10Pa.
Filling Device	It should be a special explosion-proof filling device; have certain precision and its filling deviation should be less than 5g.
Leak Detector	It should be calibrated regularly; and its annual leak rate should not exceed 10g.
Concentration	<p>A) The maintenance site should be equipped with a fixed-type combustible refrigerant concentration detector and connected to a safeguard alarm system; its error must be not more than 5%.</p> <p>B) The installation site should be equipped with a portable combustible refrigerant concentration detector which can realize two-level audible and visual alarm; its error must be not more than 10%.</p> <p>C) The concentration detectors should be calibrated regularly.</p> <p>D) It is necessary to check and confirm the functions before using the concentration detectors.</p>
Pressure Gauge	<p>A) The pressure gauges should be calibrated regularly.</p> <p>B) The pressure gauge used for Refrigerant 22 can be used for Refrigerants R290 and R161; the pressure gauge used for R410A can be used for Refrigerant 32.</p>
Fire Extinguisher	It is necessary to carry fire extinguisher(s) when installing and maintaining an air conditioner. On the maintenance site, there should be two or more kinds of dry powder, carbon dioxide and foam fire extinguishers and that such fire extinguishers should be placed at stipulated positions, with eye-catching labels and in handy places.

9. INSTALLATION MANUAL-SELECTING THE INSTALLATION PLACE

9.1 INDOOR UNIT

- Install the indoor unit on a strong wall that is not subject to vibrations.
- The inlet and outlet ports should not be obstructed: the air should be able to blow all over the room.
- Do not install the unit near a source of heat, steam or flammable gas.
- Do not install the unit where it will be exposed to direct sunlight.
- Select a site where the condensed water can be easily drained out, and where it is easily connected to outdoor unit.
- Check the machine operation regularly and reserve the necessary spaces as shown in the picture.
- Select a place where the filter can be easily taken out.

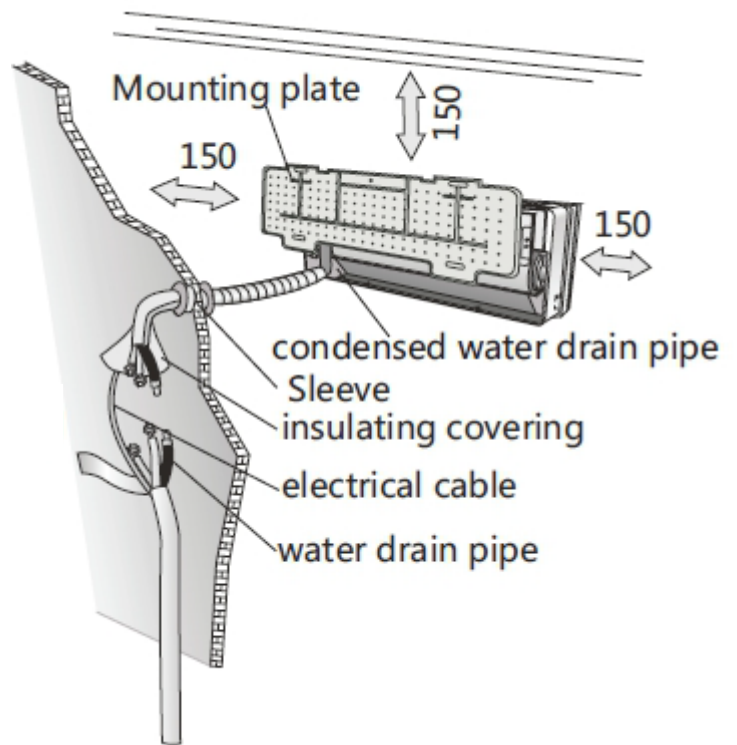

Minimum space to be reserved (mm) shown in the picture

9.2 OUTDOOR UNIT

- Do not install the outdoor unit near sources of heat, steam or flammable gas.
- Do not install the unit in too windy or dusty places.
- Do not install the unit where people often pass. Select a place where the air discharge and operating sound will not disturb the neighbours.
- Avoid installing the unit where it will be exposed to direct sunlight (otherwise use a protection, if necessary, that should not interfere with the air flow).
- Reserve the spaces as shown in the picture for the air to circulate freely.
- Install the outdoor unit in a safe and solid place.
- If the outdoor unit is subject to vibration, place rubber gaskets onto the feet of the unit.

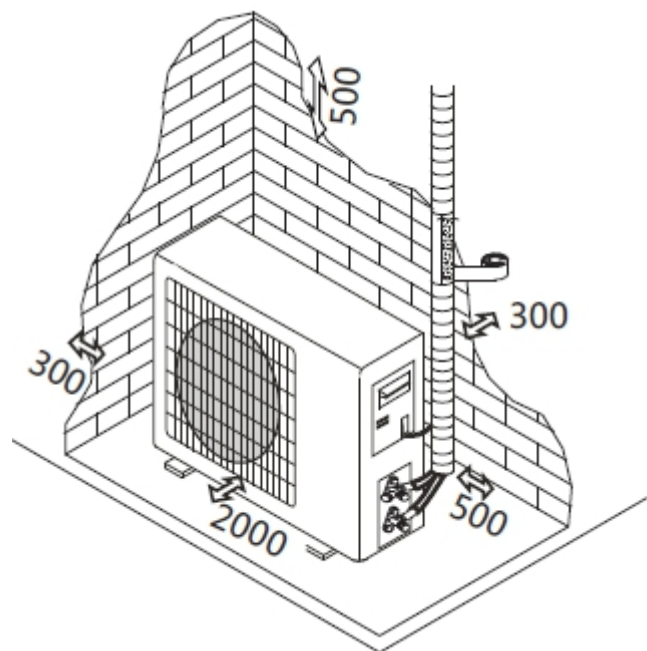

Installation Diagram

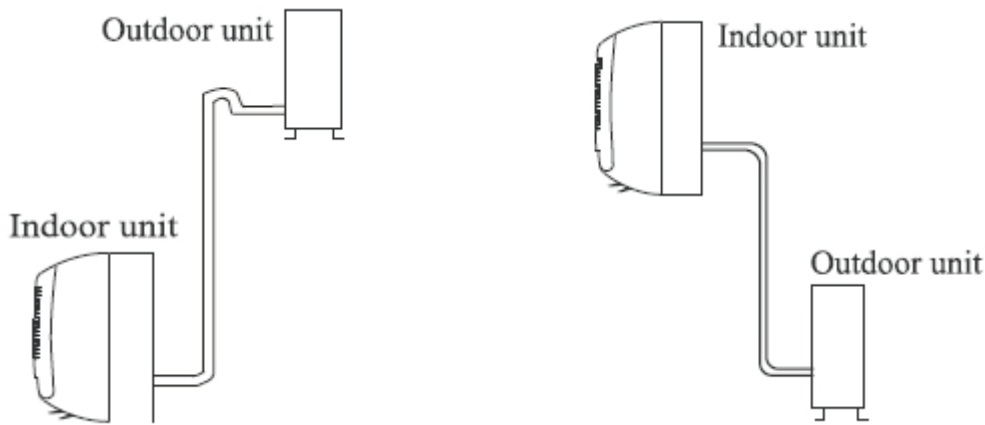

The purchaser must ensure that the person and/or company who is to install, maintain or repair this air conditioner has qualifications and experience in refrigerant products.

10. INSTALLATION MANUAL- INSTALLATION OF THE INDOOR UNIT

Before starting installation, decide on the position of the indoor and outdoor units, taking into account the minimum space reserved around the units

 Do not install your air conditioner in a wet room such as a bathroom or laundry etc.

 The installation site should be 250cm or more above the floor.

To install, proceed as follows:

10.1 INSTALLATION OF THE MOUNTING PLATE

1. Always mount the rear panel horizontally and vertically;
2. Drill 32 mm deep holes in the wall to fix the plate;
3. Insert the plastic anchors into the hole;
4. Fix the rear panel on the wall with provided tapping screws;
5. Be sure that the rear panel has been fixed firmly enough to withstand the weight.

Note:

The shape of the mounting plate may be different from the one above, but installation method is similar.

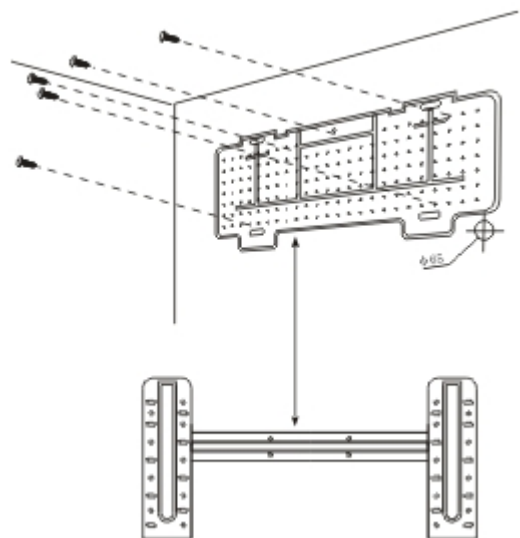

10.2 DRILLING A HOLE IN THE WALL FOR THE PIPING

1. Make the piping hole (65) in the wall at a slight downward slant to the outdoor side.
2. Insert the piping-hole sleeve into the hole to prevent the connection piping and wiring from being damaged when passing through the hole.

 The hole must slope downwards towards the exterior

Note:

Keep the drain pipe down towards the direction of the wall hole, otherwise leakage may occur.

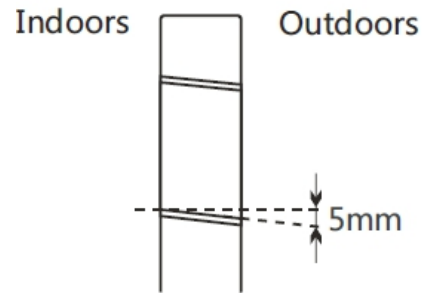

10.3 ELECTRICAL CONNECTIONS-INDOOR UNIT

1. Open the front panel.
2. Take off the cover as indicated in the picture (by removing a screw or breaking the hooks).
3. For the electrical connections, see the circuit diagram on the right part of the unit under the front panel.
4. Connect the cable wires to the screw terminals by following the numbering, use wire size suitable to the electric power input (see name plate on the unit) and according to all current national safety code requirements.

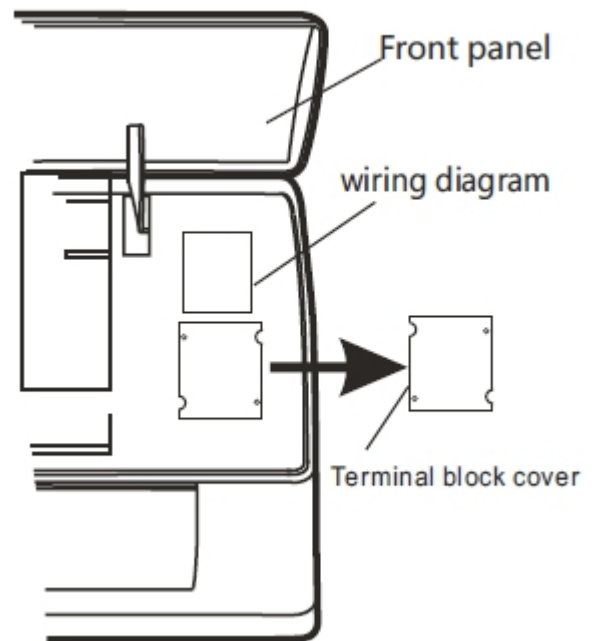

 The cable connecting the outdoor and indoor units must be suitable for outdoor use.

 The plug must be accessible also after the appliance has been installed so that it can be pulled out if necessary.

 An efficient earth connection must be ensured.

 If the power cable is damaged, it must be replaced by an authorised Service Centre.

10.4 REFRIGERANT PIPING CONNECTION

The piping can be run in the 3 directions indicated by numbers in the picture. When the piping is run in direction 1 or 3, cut a notch along the groove on the side of the indoor unit with a cutter. Run the piping in the direction of the wall hole and bind the copper pipes, the drain pipe and the power cables together with the tape with the drain pipe at the bottom, so that water can flow freely.

- Do not remove the cap from the pipe until connecting it, to avoid dampness or dirt from entering.
- If the pipe is bent or pulled too often, it will become stiff. Do not bend the pipe more than three times at one point.
- When extending the rolled pipe, straighten the pipe by unwinding it gently as shown in the picture.

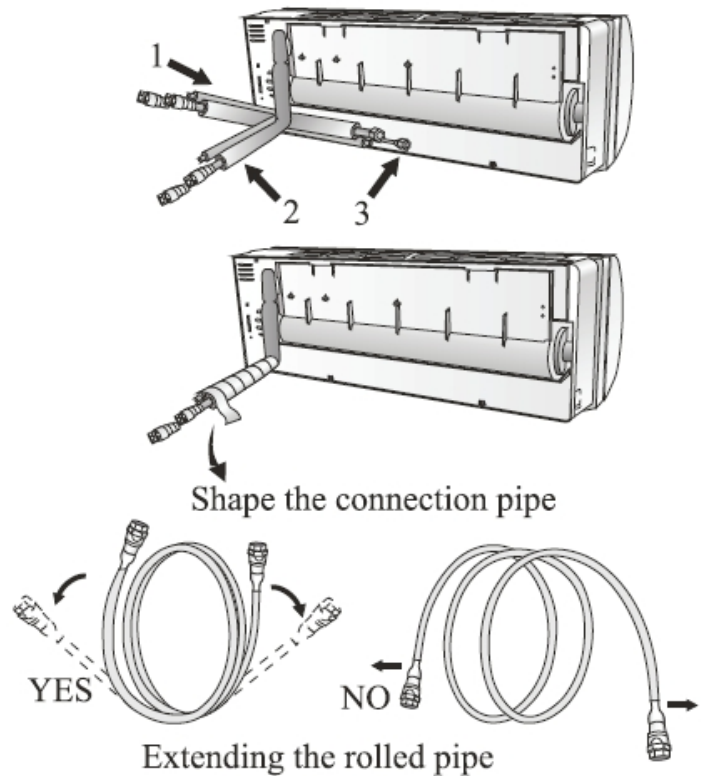

10.5 CONNECTIONS TO THE INDOOR UNIT

1. Remove the indoor unit pipe cap (check that there is no debris inside).
2. Align the refrigerant pipes correctly and tighten the first few threads by hand.
3. Tighten the connections by using two wrenches working in opposite directions.
4. For R32/R290 refrigerants, mechanical connectors should be outdoors.

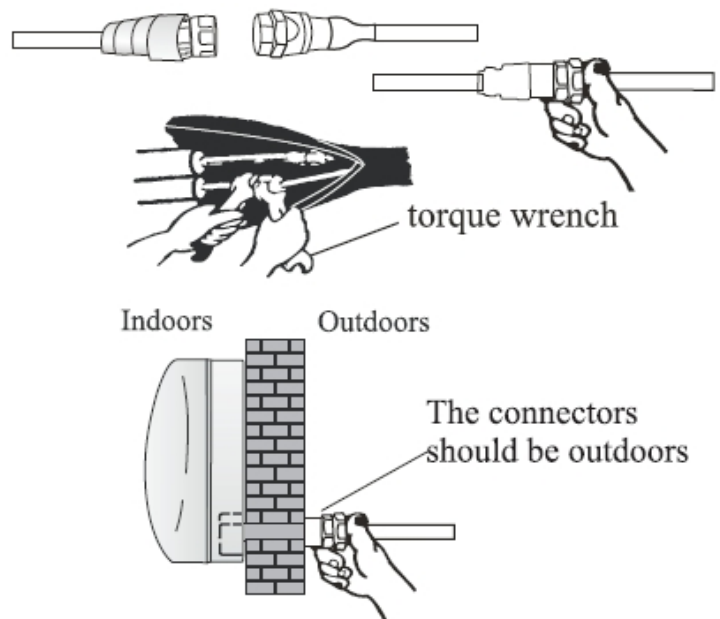

10.6 INDOOR UNIT CONDENSED WATER DRAINAGE

The indoor unit condensed water drainage is fundamental for the success of the installation.

1. Place the drain hose below the piping. Taking care not to create siphons.
2. The drain hose must slant downwards to aid drainage.

3. Do not bend the drain hose or leave it protruding or twisted and do not put the end of it in water.

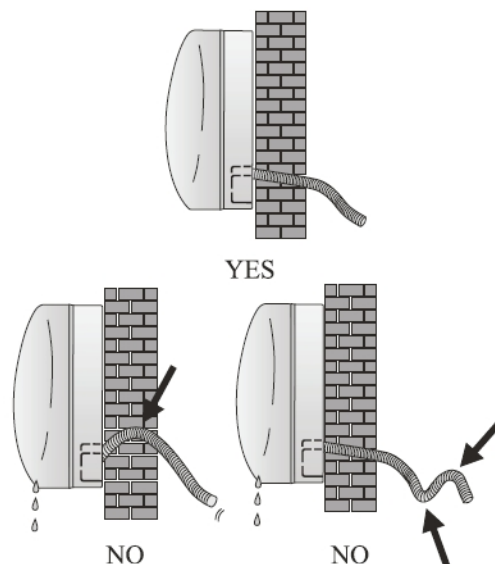

10.7 INSTALLATION OF THE INDOOR UNIT

After having connected the pipe according to the instructions, install the connection cables. Now install the drain pipe. After connection, lag the pipe, cables and drain pipe with the insulating material.

1. Arrange the pipes, cables and drain hose well.
2. Lag the pipe joints with insulating material, securing it with vinyl tape.
3. Run the bound pipe, cables and drain pipe through the wall hole and mount the indoor unit onto the upper part of the mounting plate securely.
4. Press and push the lower part of the indoor unit tightly against the mounting plate

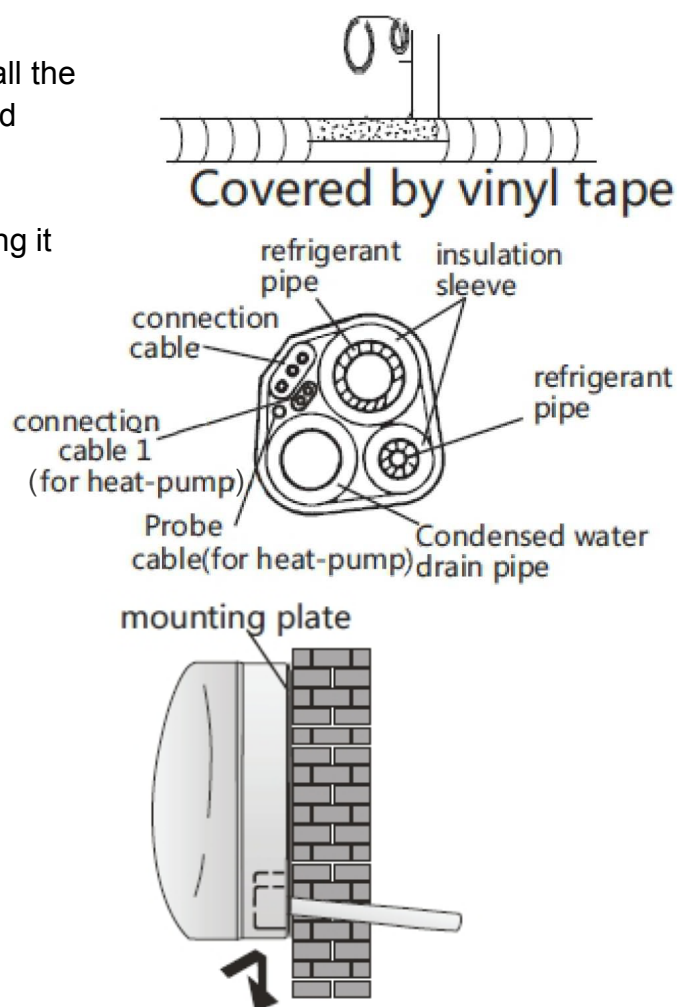

11. INSTALLATION MANUAL- INSTALLATION OF THE OUTDOOR UNIT

- The outdoor unit should be installed on a solid wall and fastened securely.
- The following procedure must be observed before connecting the pipes and connecting cables, decide which is the best position on the wall and leave enough space to be able to carry out maintenance easily.
- Fasten the support to the wall using screw anchors which are particularly suited to the type of wall;
- Use a larger quantity of screw anchors than normally required for the weight they have to bear to avoid vibration during operation and remain fastened in the same position for years without the screws becoming loose.
- The unit must be installed following the national regulations.

11.1 OUTDOOR UNIT CONDENSED WATER DRAINAGE

(only for heat pump models)

The condensed water and the ice formed in the outdoor unit during heating operation can be drained away through the drain pipe

1. Fasten the drain port in the 25mm hole placed in the part of the unit as shown in the picture.
2. Connect the drain port and the drain pipe. Pay attention that water is drained in a suitable place.

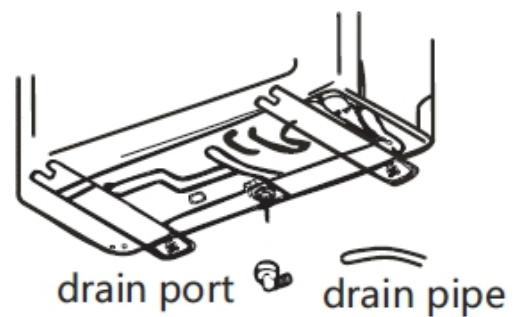

11.2 ELECTRICAL CONNECTIONS

1. Remove the handle on the right side plate of outdoor unit.
2. Connect the power connection cord to the terminal board. Wiring should fit that of indoor unit.
3. Fix the power connection cord with wire clamp.
4. Confirm if the wire has been fixed properly.
5. An efficient earth connection must be ensured.
6. Recover the handle.

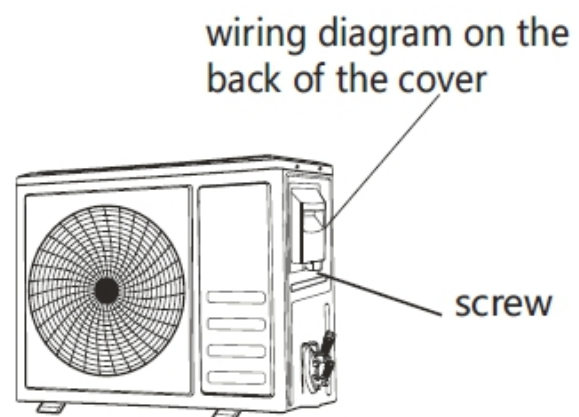

11.3 CONNECTING THE PIPES

Screw the flare nuts to the outdoor unit coupling with the same tightening procedures described for the indoor unit.

To avoid leakage, pay attention to the following points:

1. Tighten the flare nuts using two wrenches. Pay attention not to damage the pipes.
2. If the tightening torque is not sufficient, there will probably be some leakage. With excessive tightening torque there will also be some leakage, as the flange could be damaged.
3. The surest system consists in tightening the connection by using a fix wrench and a torque wrench:

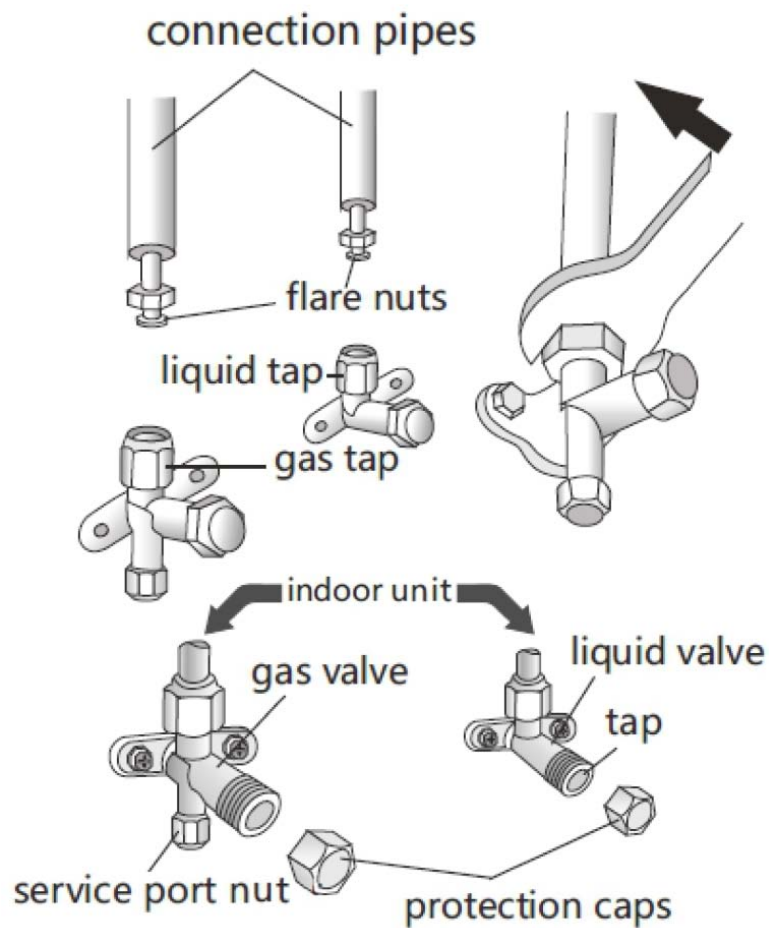

11.4 BLEEDING

Air and humidity left inside the refrigerant circuit can cause compressor malfunction. After having connected the indoor and outdoor units, bleed the air and humidity from the refrigerant circuit by using a vacuum pump.

11.5 REFRIGERANT PRESSURE INSPECTION

Air-returning Low-pressure Range of Refrigerant R290: 0.4-0.6Mpa; Air-exhausting High-pressure Range: 1.5-2.0Mpa;
 Air-returning Low-pressure Range of Refrigerant R32: 0.8-1.2Mpa; Air-exhausting High-pressure Range: 3.2-3.7Mpa;

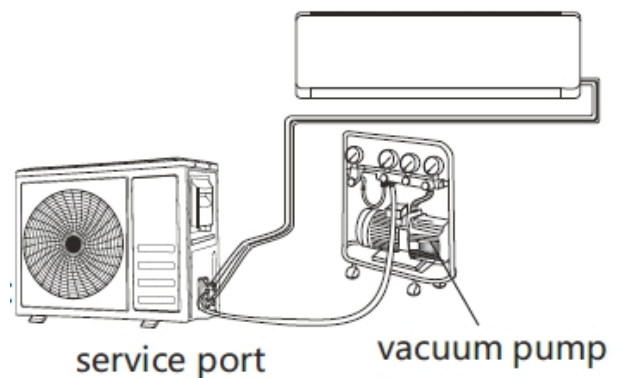

It means that the refrigerating system or refrigerant of an air conditioner is abnormal if the air-exhausting and air-returning pressure range of the detected compressor exceed the normal ranges to a large extent.

12. INSTALLATION MANUAL- OPERATION TEST

1. Wind insulating covering around the joints of the indoor unit and fix it with insulating tape.
2. Fix the exceeding part of the signal cable to the piping or to the outdoor unit.
3. Fix the piping to the wall (after having coated it with insulating tape) using clamps or insert them into plastic slots.
4. Seal the hole in the wall through which the piping is passed so that no air or water can fill.

12.1 INDOOR UNIT TEST

- Do the ON/OFF and FAN operate normally?
- Does the MODE operate normally?
- Do the set point and TIMER function properly?
- Does each lamp light normally?
- Does the flap for air flow direction operate normally?
- Is the condensed water drained regularly?

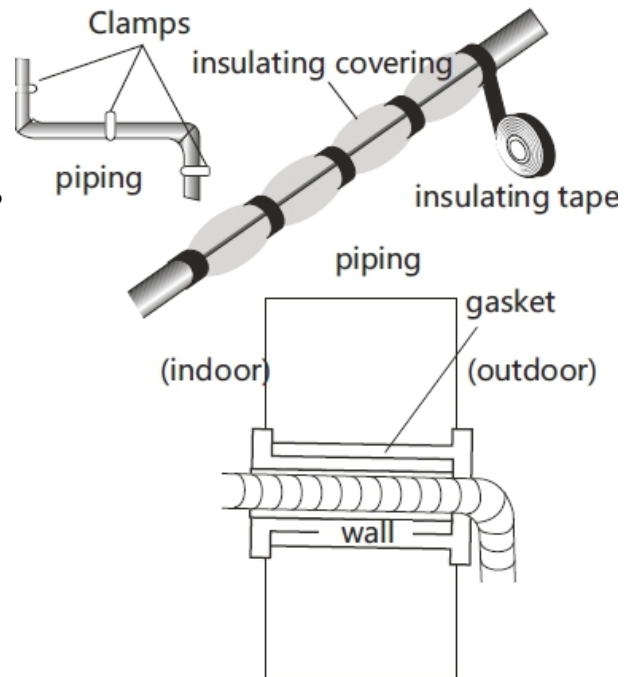

12.2 OUTDOOR UNIT TEST





- Is there any abnormal noise or vibration during operation?
- Could the noise, the air flow or the condensed water drainage disturb the neighbours?
- Is there any coolant leakage?





Note: the electronic controller allows the compressor to start only three minutes after voltage has reached the system.

13. INSTALLATION MANUAL- INFORMATION FOR THE INSTALLER

MODEL capacity (Btu/h)	9k/12k	18k/24k
Lenght of pipe with standard charge	5m	5m
Maximum distance between indoor and outdoor unit	25m	25m
Additional refrigerant charge	15g/m	25g/m
Max. diff. in level between indoor and outdoor unit	10m	10m
Type of refrigerant(1)	R32/R290	R32/R290

(1) REFER TO THE DATA RATING LABEL STICKED ON THE OUTDOOR UNIT.

   		
CLIMATISEUR MURAL		
EZ3500FC3A		
Model	Indoor	EZ3500FC3A
	Outdoor	EZ3500FC3A
	Cooling	Heating
Capacity	3660W	3940W
Current	5.4A (1.2~7.2)	4.5A (1.2~8.0)
Rated Current (IEC/EN60335)	7.2A	8.0A
Power Input	966A (240~1600)	1010A (240~1750)
Rated Power Input (IEC/EN60335)	1600W	1750W
Indoor Air Volume	850m ³ /h	850m ³ /h
Max. Pressure	Discharge	3.7MPa
	Suction	1.2MPa
Sound Pressure	Indoor	53dB(A)
	Outdoor	62dB(A)
Weight	Indoor	10.5kg
	Outdoor	28kg
Rated Voltage	220-240V~	
Rated Frequency	50Hz	
Refrigerant/Charge/GWP	R32/0.80kg/675	
CO ₂ equivalent	0.54 tonnes	
Contains fluorinated greenhouse gases		
Outdoor Unit Water Proof Protection IPX4		
S/N: 20210335857		
BUILDER SAS		
32, rue Aristide Bergés-ZI 31270 Cugnaux-France		
Made in PRC - 2021		

   		
CLIMATISEUR MURAL		
EZ2600FC3A		
Model	Indoor	EZ2600FC3A
	Outdoor	EZ2600FC3A
	Cooling	Heating
Capacity	2760W	2900W
Current	3.8A (1.2~6.5)	3.7A (1.2~7.0)
Rated Current (IEC/EN60335)	6.5A	7.0A
Power Input	620A (200~1450)	660A (200~1550)
Rated Power Input (IEC/EN60335)	1450W	1550W
Indoor Air Volume	850m ³ /h	850m ³ /h
Max. Pressure	Discharge	3.7MPa
	Suction	1.2MPa
Sound Pressure	Indoor	53dB(A)
	Outdoor	62dB(A)
Weight	Indoor	10.5kg
	Outdoor	25kg
Rated Voltage	220-240V~	
Rated Frequency	50Hz	
Refrigerant/Charge/GWP	R32/0.620kg/675	
CO ₂ equivalent	0.419 tonnes	
Contains fluorinated greenhouse gases		
Outdoor Unit Water Proof Protection IPX4		
S/N: 20210332857		
BUILDER SAS		
32, rue Aristide Bergés-ZI 31270 Cugnaux-France		
Made in PRC - 2021		

(2) THE TOTAL CHARGE AMOUNT SHOULD UNDER THE MAXIMUM ACCORDING TO THE TABLE GG.1 ON PAGE 32.

Torque Parameters

PIPE Size	Newton meter[N x m]	Pound-force foot (1bf-ft)	Kilogram-force meter (kgf-m)
1/4 " (φ 6.35)	18 - 20	24.4 - 27.1	2.4 - 2.7
3/8 " (φ 9.52)	30 - 35	40.6 - 47.4	4.1 - 4.8
1/2 " (φ 12)	45 - 50	61.0 - 67.7	6.2 - 6.9
5/8 " (φ 15.88)	60 - 65	81.3 - 88.1	8.2 - 8.9

13.3 WIRING DIAGRAM

For different models, the wiring diagram may be different. Please refer to the wiring diagrams pasted on the indoor unit and outdoor unit respectively.

On indoor unit, the wiring diagram is pasted under the front panel;

On outdoor unit, the wiring diagram is pasted on the backside of the outdoor handle cover.

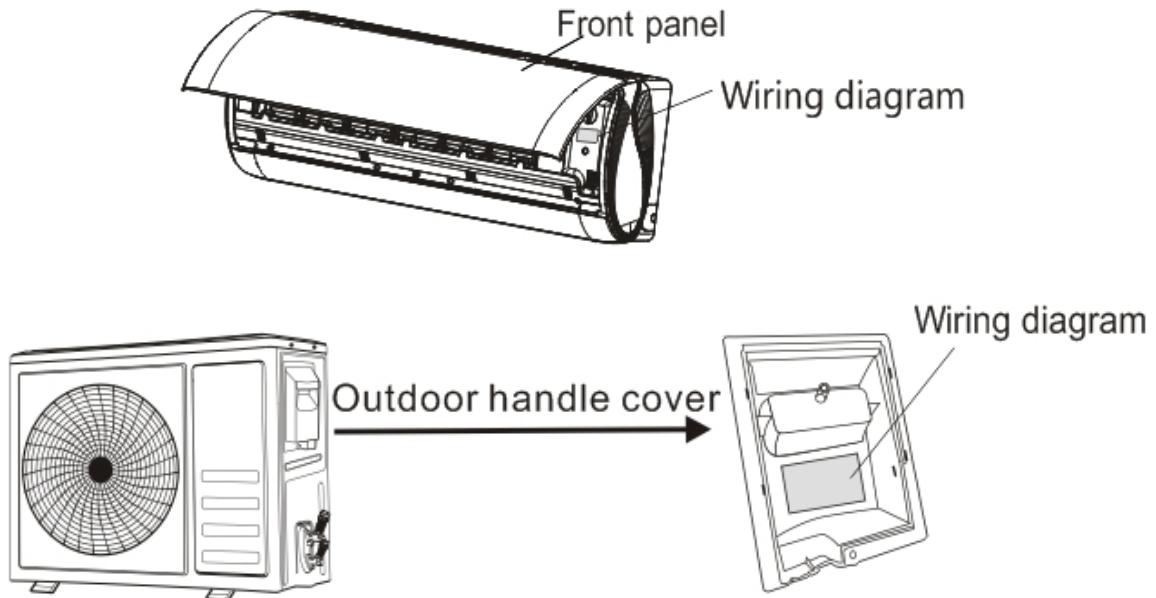

Note: For some models the wires have been connected to the main PCB of indoor unit by manufacturer without terminal block.

13.4 CABLE WIRES SPECIFICATION

INVERTER TYPE MODEL capacity (Btu/h)	LINES	9k	12k
Power supply cable	N	1.0mm ²	1.5mm ²
	L	1.0mm ²	1.5mm ²
	⊕	1.0mm ²	1.5mm ²
Connection supply cable	N	1.0mm ²	1.5mm ²
	L	1.0mm ²	1.5mm ²
	1	1.0mm ²	1.5mm ²
	⊕	1.0mm ²	1.5mm ²

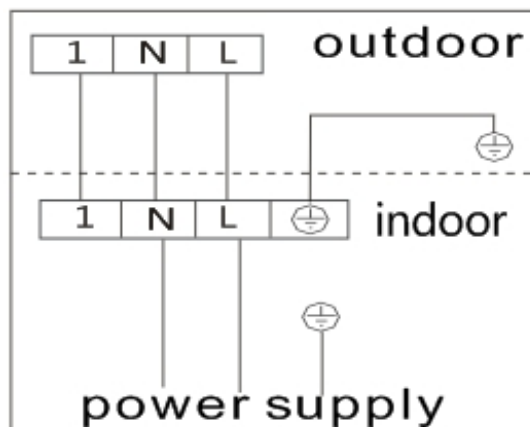

14. MAINTENANCE

Periodic maintenance is essential for keeping your air conditioner efficient.

Before carrying out any maintenance, disconnect the power supply by taking the plug out from the socket.

14.1 INDOOR UNIT

ANTIDUST FILTERS

1. Open the front panel following the direction of the arrow.
2. Keeping the front panel raised with one hand, take out the air filter with the other hand.
3. Clean the filter with water; if the filter is soiled with oil, it can be washed with warm water (not exceeding 45°C). Leave to dry in a cool and dry place.
4. Keeping the front panel raised with one hand, insert the air filter with the other hand.

14.2 CLEANING THE HEAT EXCHANGER

1. Open the front panel of the unit and lift it until its greatest stroke and then unhook it from the hinges to make the cleaning easier.
2. Clean the indoor unit using a cloth with the water (not higher than 40) and neutral soap. Never use aggressive solvents or detergents.
3. If the outdoor unit is clogged, remove the leaves and the waste and remove the dust with air jet or a bit of water.

14.3 END OF SEASON MAINTENANCE

1. Disconnect the automatic switch or the plug.
2. Clean and replace the filters.
3. On a sunny day let the conditioner work in ventilation for some hours, so that the inside of the unit can dry completely.

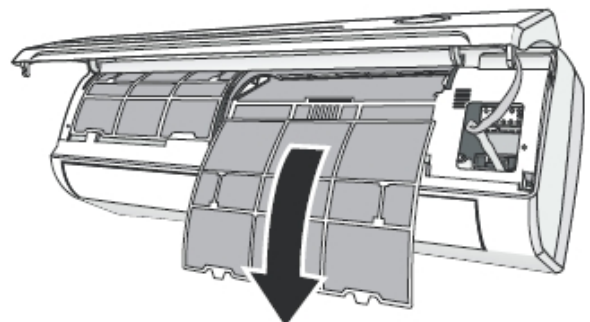
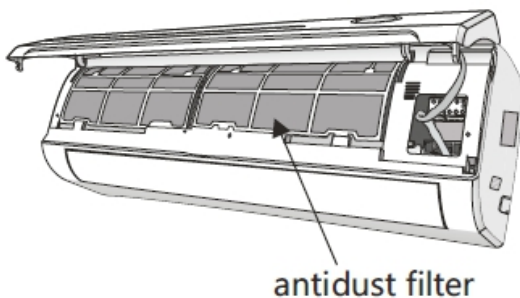
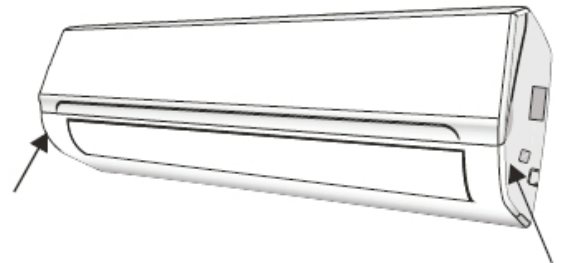

15. TROUBLESHOOTING

MALFUNCTION	POSSIBLE CAUSES
The appliance does not operate	Power failure/plug pulled out.
	Damaged indoor/outdoor unit fan motor.
	Faulty compressor thermomagnetic circuit breaker.
	Faulty protective device or fuses.
	Loose connections or plug pulled out.
	It sometimes stops operating to protect the appliance.
	Voltage higher or lower than the voltage range.
	Active TIMER-ON function.
	Damaged electronic control board.
Strange odor	Dirty air filter.
Noise of running water	Back flow of liquid in the refrigerant circulation.
A fine mist comes from the air outlet	This occurs when the air in the room becomes very cold, for example in the COOLING or DEHUMIDIFYING/DRY modes.
A strange noise can be heard	This noise is made by the expansion or contraction of the front panel due to variations in temperature and does not indicate a problem.
Insufficient airflow, either hot or cold	Unsuitable temperature setting.
	Obstructed air conditioner intakes and outlets.
	Dirty air filter.
	Fan speed set at minimum.
	Other sources of heat in the room.
The appliance does not respond to commands	No refrigerant.
	Remote control is not close enough to indoor unit.
	The batteries of remote control need to be replaced.
The display is off	Obstacles between remote control and signal receiver in indoor unit.
	Active LIGHT function.
Switch off the air conditioner immediately and cut off the power supply in the event of:	Power failure.
	Strange noises during operation.
	Faulty electronic control board.
	Faulty fuses or switches.
	Spraying water or objects inside the appliance.
	Overheated cables or plugs.
Very strong smells coming from the appliance.	

ERROR SIGNALS ON THE DISPLAY			
In case of error, the display on the indoor unit shown the following error codes:			
Display	Description of the trouble	Display	Description of the trouble
E1	Indoor temperature sensor fault	E8	Outdoor discharge temperature sensor fault
E2	Indoor pipe temperature sensor fault	E9	Outdoor IPM module fault
E3	Outdoor pipe temperature sensor fault	EA	Outdoor current detect fault

E4	Malfunction of indoor fan motor	EE	Outdoor PCB EEPROM fault
E6	Refrigerant system leakage or fault	EF	Outdoor fan motor fault
E7	Outdoor air temperature sensor fault	EH	Outdoor suction temperature sensor fault

16. DISPOSAL

Disposal of the appliance

A crossed-out wheellie bin icon means: Batteries and rechargeable batteries, electrical or electronic devices must not be disposed of with household waste. They may contain substances that are harmful to the environment and human health.

Consumers must dispose of waste electrical devices, spent portable batteries and rechargeable batteries separately from household waste at an official collection point to ensure that these items are processed correctly. Information on returning these items is available from the seller. Sellers are required to accept these items free of charge.



Batteries and rechargeable batteries, which are not permanently installed in waste electrical devices, must be removed prior to disposal and must be disposed of separately.

Lithium batteries and battery packs in all systems must only be returned to a collection point when discharged.

Batteries must always be protected against short circuits by covering the poles with adhesive tape.

All end users are responsible for deleting any personal data stored on waste devices prior to their disposal.



Disposal of the packaging

The packaging consists of cardboard and correspondingly marked plastics that can be recycled.

Make these materials available for recycling.



17. WARRANTY

Energizer[®]

WARRANTY

The manufacturer guarantees the product against defects in material and workmanship for a period of 2 years from the date of the original purchase. The warranty only applies if the product is for household use. The warranty does not cover breakdowns due to normal wear and tear.

The manufacturer agrees to replace parts identified as defective by the designated distributor. The manufacturer does not accept responsibility for the replacement of the machine, in whole or in part, and/or ensuing damage.

The warranty does not cover breakdowns due to:

- insufficient maintenance.
- abnormal assembly, adjustment or operations of the product.
- parts subject to normal wear and tear.

The warranty does not extend to:

- shipping and packaging costs.
- using the tool for a purpose other than that for which it was designed.
- the use and maintenance of the machine done in a manner not described in the user manual.

Due to our policy of continuous product improvement, we reserve the right to alter or change specifications without notice. Consequently, the product may be different from the information contained therein, but a modification will be undertaken without notice if it is recognized as an improvement of the preceding characteristic.

READ THE MANUAL CAREFULLY BEFORE USING THE MACHINE.

When ordering spare parts, please indicate the part number or code, you can find this in the spare parts list in this manual. Keep the purchase receipt; without it, the warranty is invalid. To help you with your product, we invite you to contact us by phone or via our website:

- **+33 (0)9.70.75.30.30**
- **<https://services.swap-europe.com/contact>**

You must create a "ticket" via the web platform.

- Register or create your account.
- Indicate the reference of the tool.
- Choose the subject of your request.
- Describe your problem.
- Attach these files: invoice or sales receipt, photo of the identification plate (serial number), photo of the part you need (for example: pins on the transformer plug which are broken).



18. PRODUCT FAILURE

WHAT TO DO IF MY MACHINE BREAKS DOWN?

If you bought your product in a store:

- a) Empty the fuel tank if your product has one.
- b) Make sure that your machine is complete with all accessories supplied, and clean! If this is not the case, the repairer will refuse the machine.

Go to the store with the complete machine and with the receipt or invoice.

If you bought your product on a website:

- a) Empty the fuel tank if your product has one.
- b) Make sure that your machine is complete with all accessories supplied, and clean! If this is not the case, the repairer will refuse the machine.
- c) Create a SWAP-Europe service ticket on the site: <https://services.swap-europe.com> When making the request on SWAP-Europe, you must attach the invoice and the photo of the nameplate (serial number).
- d) Contact the repair station to make sure it is available before dropping off the machine.

Go to the repair station with the complete machine packed, accompanied by the purchase invoice and the station support sheet downloadable after the service request is completed on the SWAP-Europe site.

For machines with engine failure from manufacturers BRIGGS & STRATTON, HONDA and RATO, please refer to the following instructions.

Repairs will be done by approved engine manufacturers of these manufacturers, see their site:

- <http://www.briggsandstratton.com/eu/fr>
- <http://www.honda-engines-eu.com/fr/service-network-page;jsessionid=5EE8456CF39CD572AA2AEEDFD290CDAE>
- <https://www.rato-europe.com/it/service-network>

Please keep your original packaging to allow for after-sales service returns or pack your machine with a similar cardboard box of the same dimensions.

For any question concerning our after-sales service you can make a request on our website <https://services.swap-europe.com>

Our hotline remains available at +33 (9) 70 75 30 30.



19. WARRANTY EXCLUSIONS

THE WARRANTY DOES NOT COVER:

- Start-up and setting up of the product.
- Damage resulting from normal wear and tear of the product.
- Damage resulting from improper use of the product.
- Damage resulting from assembly or start-up not in accordance with the user manual.
- Breakdowns related to carburetion beyond 90 days and fouling of carburetors.
- Periodic and standard maintenance events.
- Actions of modification and dismantling that directly void the warranty.
- Products whose original authentication marking (brand, serial number) has been degraded, altered or withdrawn.
- Replacement of consumables.
- The use of non-original parts.
- Breakage of parts following impacts or projections.
- Accessories breakdowns.
- Defects and their consequences linked to any external cause.
- Loss of components and loss due to insufficient screwing.
- Cutting components and any damage related to the loosening of parts.
- Overload or overheating.
- Poor power supply quality: faulty voltage, voltage error, etc.
- Damages resulting from the deprivation of enjoyment of the product during the time necessary for repairs and more generally the costs related to the immobilization of the product.
- The costs of a second opinion established by a third party following an estimate by a SWAP-Europe repair station
- The use of a product which would show a defect or a breakage which was not the subject of an immediate report and/or repair with the services of SWAP-Europe.
- Deterioration linked to transport and storage*.
- Launchers beyond 90 days.
- Oil, petrol, grease.
- Damages related to the use of non-compliant fuels or lubricants.

* In accordance with transport legislation, damage related to transport must be declared to carriers within 48 hours maximum after observation by registered letter with acknowledgement of receipt.

This document is a supplement to your notice, a non-exhaustive list.

Attention: All orders must be checked in the presence of the delivery person. In case of refusal by the delivery person, you must simply refuse the delivery and notify your refusal.

Reminder: The reserves do not exclude the notification by registered letter with acknowledgement within 72 hours.

Information: Thermal devices must be wintered each season (service available on the SWAP-Europe site). Batteries must be charged before being stored.

Energizer®