



**ORIGINAL INSTRUCTIONS**

**LEAF BLOWERS VACUUMS**

**FAST175T -1/ FAST175P-1**

**USER MANUAL**



● **Note:** Because the manual of this product is not divided into high and low configuration independent versions, The internal description is a full-featured version of the machine. So the description of the function that is not available on the machine you purchased will appear in it.

For this we use the "△" to distinguish this function description in the following content, You can also compare on this page. If your machine is not configured with the function or operation instructions marked "△", Then please skip here.

## Included accessories

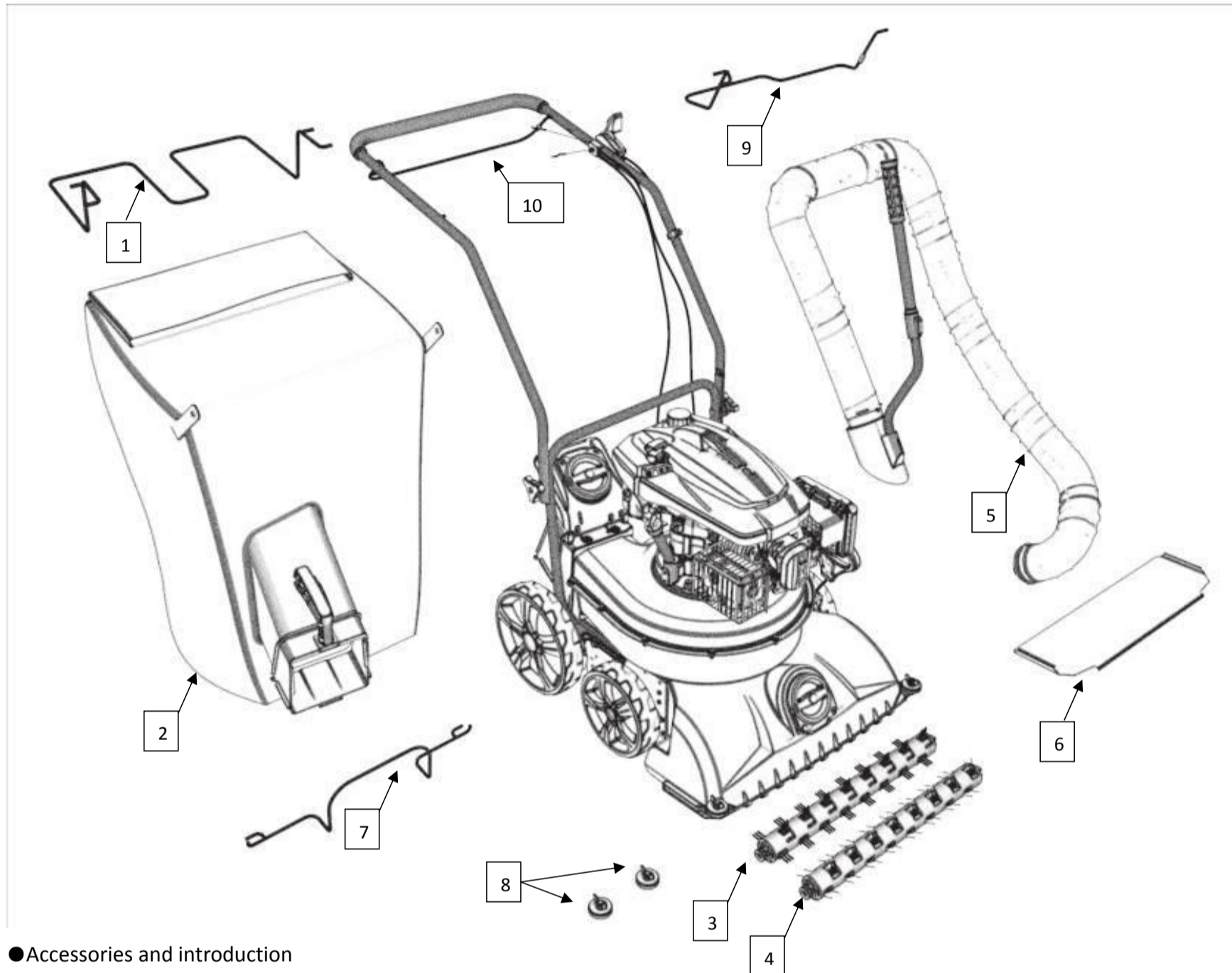

### ● Accessories and introduction

Accessories (1) Collection bag fixing bracket—Used to fixed collection bags

(Must assembled)

Accessories (2) Collection bag—Collecting inhaled garbage

(Must assembled)

△ Accessories (3) Cleaning disk—Used to clean the ground

(Optional)

△ Accessories (4) Comb brush—Used to comb the lawn

(Optional)

△ Accessories (5) Auxiliary hose—Blowing or sucking away rubbish in areas that the machine cannot enter

(Optional)

△ Accessories (6) Suction port baffle—When the suction port is completely closed by the flap, Maximize the vacuum of the hose

(Optional)

Accessories (7) Hose bracket—Used to suspend hoses and hang collection bags

(Must assembled)

△ Accessories (8) pulley—When an impact occurs, change the direction of the machine and protect the suction port

(Optional)

△ Accessories (9) Rear wheel drive lever—Used to drive rear wheel self-propelled

(Optional)

△ Accessories (10) Roller brush drive lever—Used to drive rear Roller brush

(Optional)

● **Note:** When assembling the machine, please select one of the assemblies (3) and (4) according to your needs or work area, or neither.

**⚠ Warning:** For your own safety, please read this manual before attempting to operate a new device. Failure to follow instructions can result in serious personal injury. Take time to familiarize yourself with the machine before each use.

# Table of Contents

<b>Included accessories.....</b>	<b>2</b>
<b>Table of Contents.....</b>	<b>3</b>
<b>Chapter 1 Safety and specification introduction.....</b>	<b>4-7</b>
1) Product safety warning.....	4
2) Indicator mark.....	6
3) Control mark.....	6
4) Parameter mark.....	6
5) LOGO mark.....	7
<b>Chapter 2 Assembly instructions.....</b>	<b>8-13</b>
1) Rear wheel drive lever assembly.....	8
2) Upper armrest assembly.....	8
3) Collection bag fixing bracket assembly.....	9
4) Hose bracket assembly.....	9
5) Collection bag assembly.....	9
6) Roller brush assembly.....	12
7) Auxiliary hose assembly.....	12
8) Suction port baffle assembly.....	13
9) pulley assembly.....	13
<b>Chapter 3 Product specification.....</b>	<b>14</b>
1) Host parameter.....	14
2) Accessory parameters.....	14
<b>Chapter 4 Instructions for use.....</b>	<b>15-21</b>
1) Start the machine.....	15
2) Adjust the height of the suction inlet.....	15
3) The use and function of the guide wheel.....	16
4) Start and function of the roller brush.....	16
5) self-propelled Operating Instructions for use.....	18
6) Auxiliary hose instructions for use.....	18
7) Collection bag Instructions for use.....	20
8) Stop the engine.....	21
<b>Chapter 5 Lubrication instructions.....</b>	<b>22</b>
<b>Chapter 6 Engine description.....</b>	<b>22</b>
<b>Chapter 7 Machine cleaning and storage.....</b>	<b>22-23</b>
1) clean.....	22
2) storage.....	23
<b>Chapter 8 Machine maintenance instructions.....</b>	<b>23</b>
1) The importance of proper maintenance.....	23
2) Maintenance safety.....	23
3) Safety instructions.....	23
4) Routine maintenance.....	23
<b>Chapter 9 Maintenance planning cycle.....</b>	<b>24</b>
<b>Chapter 10 Troubleshooting and solutions.....</b>	<b>25-26</b>
<b>Chapter 11 Environmental protection.....</b>	<b>26</b>
<b>Chapter 12 Declaration of conformity.....</b>	<b>27</b>
<b>Chapter 13 WARRANTY.....</b>	<b>28</b>
<b>Chapter 14 PRODUCT FAILURE.....</b>	<b>29</b>
<b>Chapter 15 WARRANTY EXCLUSIONS.....</b>	<b>30</b>

**⚠ WARNING: If any of the labels are damaged or missing, replace them before operating the equipment.**

## **Chapter 1: Safety and specification introduction**

---

### **Intended use**

- This blower is meant to be used for blowing leaves, dust or garden debris into a desired direction. It must not be used for blowing water, chemical products, flammable material, metal or wood and other dangerous objects.
- This product is intended for private domestic use only. It must be used outdoors.
- This product is not intended to be used in a closed room and places where exhausted gas and flames can be present.
- The use of this product in case of rain or humid environments is prohibited.
- Any other use might lead to damage of the appliance, property or personal injury.

### **1 ) Product safety warning**

- This appliance is not intended for use by persons (including children) with reduced physical, sensory or mental capabilities, or lack of experience and knowledge, unless they have been given supervision or instruction concerning use of the appliance by a person responsible for their safety.
- Children should be supervised to ensure that they do not play with the appliance.
- Never allow children, persons with reduced physical, sensory or mental capabilities or lack of experience and knowledge or people unfamiliar with these instructions to use the machine, local regulations may restrict the age of the operator.
- Never use the machine when people, especially children, or pets are nearby.
- Remember that the operator or user is responsible for accidents or hazards occurring to persons or their belongings.
- Do not disassemble the tool yourself. Disassembly, repair or verification must be made exclusively by qualified personnel.
- WEAR CLOSE FITTING, TOUGH WORK CLOTHING that will provide protection, such as long slacks or trousers, safety work shoes, heavy duty work gloves, hard hat, a safety face shield, or safety glasses for eye protection. The tool is extremely noisy and requires the use of ear protection, such as a good grade of ear plugs or other sound barriers.
- Always carry the machine by its handle; never use any other part of the machine.
- REFUEL IN A SAFE PLACE. Open fuel cap slowly to release any pressure which may have formed in fuel tank. Always wipe unit of fuel or oil spills before starting. To prevent a fire hazard, move at least 10 feet (3meters) from fueling area before starting.
- TURN UNIT OFF before setting it down and also before installing or removing attachments.
- KEEP ALL SCREWS AND FASTENERS TIGHT and the unit in good operating condition. Never operate this equipment if it is improperly adjusted or not completely and securely assembled.
- KEEP HANDLES DRY, clean and free of fuel mixture.
- STORE EQUIPMENT AWAY FROM POSSIBLE IGNITION SOURCES, such as gas-powered water heaters, clothes dryers, or oil-fired furnaces, portable heaters, etc.
- ALWAYS KEEP the engine free of debris build-up.
- OPERATION OF EQUIPMENT should always be restricted to mature and properly instructed individuals.
  
- ALL PERSONS WITH RESPIRATORY PROBLEMS and persons operating blower in very dusty environments, should wear a dust particle mask at all times. Paper dust masks are available at most paint and hardware stores.
- Operate the machine only at reasonable hours - not early in the morning or late at night when people might be disturbed. Comply with times listed in local ordinances.
- Avoid using the machine in bad weather, especially when there is a risk of thunderstorms and lightning.
- In case of accident, immediately stop using the machine. Turn the machine off and check the problem. Do not use the machine while the machine is damaged.
- If the machine should start making any unusual noise or vibration, immediately shut off the power source and allow the machine to stop. Take the following steps before restarting and operating the machine:
  - a) Inspect for damage;
  - b) Replace or repair any damaged parts;
  - c) Check for and tighten any loose parts.
- If the machine becomes clogged, shut-off the power source before cleaning debris.
- Never operate the machine with defective guards or shields, or without safety devices in place.
- Keep the power source clean of debris and other accumulations to prevent damage to the power source or possible fire.
- Do not carry this machine while it is in operation. Always switch off the tool and always transport it by its handle and in order to avoid accidents and a fuel leak.
- Stop the machine and make sure that all moving parts have come to a complete stop
  - a) Whenever you leave the machine;
  - b) Before clearing blockages or unclogging chute;
  - c) Before checking, cleaning or working on the machine.
- Do not tilt the machine while the power source is running.
- Operate the machine at the lowest possible engine speed to do the job. Like this, vibration and noise levels as well as the tool's

wear can be kept to a minimum.

- Use rakes and brooms to loosen debris before blowing.
- In dusty conditions, slightly dampen surfaces.
- Use the full blower nozzle extension so the air stream can work close to the ground.
- Watch out for children, pets, open windows etc. and blow debris safety away.

**WARNING: DO NOT USE ANY OTHER FUEL** than that recommended in your manual. Always follow instructions in the Fuel and Lubrication section of this manual. Never use gasoline unless it is properly mixed with 2-cycle engine lubricant. Permanent damage to engine will result, voiding manufacturer's warranty.

- **DO NOT SMOKE** while refueling or operating equipment.
- **DO NOT OPERATE UNIT WITHOUT A MUFFLER** and properly installed muffler shield.
- **DO NOT TOUCH** or let your hands or body come in contact with a hot muffler or spark plug wire.
- **DUE TO THE DANGER** of exhaust fumes, never operate blower in a confined or poorly ventilated area.
- **NEVER POINT BLOWER** in the direction of people, animals, buildings, automobiles, or open windows, etc.
- **DO NOT** operate unit without inlet cover installed to prevent contact with impeller.
- **DO NOT** set a hot engine down where flammable material is present.
- **DO NOT OPERATE UNIT FOR PROLONGED PERIODS.** Rest periodically to prevent damage from vibration, damage to ears or damage to the appliance.
- Operate the machine in a recommended position and only on a firm, level surface.
- Do not operate the machine on a paved or gravel surface where ejected material could cause injury.

**WARNING: DO NOT ADD, REMOVE OR ALTER ANY COMPONENTS OF THIS PRODUCT.** Doing so could cause personal injury and/or damage the unit, voiding the manufacturer's warranty.

- **DO NOT OPERATE UNIT WHILE TIRED, SICK OR UNDER THE INFLUENCE OF ALCOHOL OR DRUGS.**
  - **DO NOT** operate your unit near or around flammable liquids or gases whether in or out of doors. An explosion and/or fire may result.
  - **DO NOT WEAR** loose clothing, scarfs, neck chains, unconfined long hair, and the like. Doing so could cause injury associated with objects being drawn into the rotating parts.
  - **DO NOT** refuel a running engine or an engine that is hot.
  - Before using, always visually inspect to see that fasteners are secure, the housing is undamaged and that guards and screens are in place. Replace worn or damaged components in sets to preserve balance. Replace damaged or unreadable labels.
  - Before starting the machine, make certain that the tube is empty.
  - Keep your face and body away from the nozzle.
  - Do not allow hands or any other part of the body or clothing inside the discharge chute or near any moving part.
  - Keep proper balance and footing at all times. Do not overreach. Never stand at a higher level than the base of the machine when blowing material with it.
  - Always stand clear of the discharge zone when operating this machine.
- To reduce the risk of hearing loss associated with sound level, hearing protection is required.
  - To reduce the risk of injury associated with contacting rotating parts, stop the engine before installing or removing attachments. Do not operate without guard in place. Always disconnect the spark plug before performing maintenance or accessing any movable parts.
  - Do not point the blower nozzle in the direction of people or pets.
  - Never run the unit without the proper equipment attached. When used as a blower, always install the blower tubes.
  - operate the machine only at reasonable hours – not early in the morning or late at night when people might be disturbed;
  - Do not to operate the machine near open windows.
  - use rakes and brooms to loosen debris before blowing
  - slightly dampen surfaces in dusty conditions or use mister attachment;
  - Limit the time of use of the tool. Take a time of rest between 2 operations. Do not work earlier or later in the night. Do be exposed to noise and vibration for a prolonged time. Noise can bring damage to the ears.
  - This machine is extremely noisy. Always wear a hearing protection when use the tool.
  - In the event of accident or breakdown, stop to use the machine. Switch off the tool and wait until it completely stops. Check the problem. In case of blockage, clear the blockage carefully. In case of breakdown, bring the tool to an after sales service for inspection and reparation. Only use the tool when it is safely unblocked.
  - operate the machine only at reasonable hours – not early in the morning or late at night when people might be disturbed;
  - **WARNING – there is danger from rotating parts; do not enter in contact with them.**

#### **Maintenance and storage**

When the machine is stopped for servicing, inspection, or storage, or to change an accessory, shut off the power source and make sure that all moving parts have come to a complete stop. Allow the machine to cool before making any inspections, adjustments, etc. Maintain the machine with care and keep it clean.

- Store the machine in a dry place out of the reach of children.
- Always allow the machine to cool before storing.
- Replace worn or damaged parts for safety. Use only genuine replacement parts and accessories.
- Never attempt to override the interlocked feature of the guard.

#### **Residuals risks**

Even if you use this product in compliance with all safety requirements, potential risks of injury and damage remain. The following hazards may arise from the structure and design of this product. Always be vigilant when using this product, so you can recognize and manage the risks early. Rapid intervention can prevent serious injury and property damage. Turn off the tool if there are any malfunctions. Have it checked by a qualified professional and have repairs carried out, if necessary, before using it again.

- There are harmful health consequences resulting from the emission of vibrations if the product is used for long periods of time or not properly managed and properly maintained.
- There is risk of injury and property damage due to attachments or broken the sudden impact of hidden objects.
- Risk of injury to persons and property caused by flying objects.
- Prolonged use of this product exposes the operator to vibration and can produce so-called "white finger" disease. To reduce the risk, wear gloves and keep your hands warm.
- If any of the symptoms of "white finger syndrome" occur, seek immediate medical attention. Symptoms of the "white finger" include numbness, loss of sensitivity, tingling, tingling, and pain, loss of strength, color changes or skin condition. These symptoms usually appear on the fingers, hands or wrists. Risk increases at low temperatures.
- Inhalation of particles of material blown.
- Unattended projections.
- Contact with foreign objects.
- Contact with the tool in operation.
- Hearing loss in the absence of correct hearing protection.

## 2 ) Indicator mark

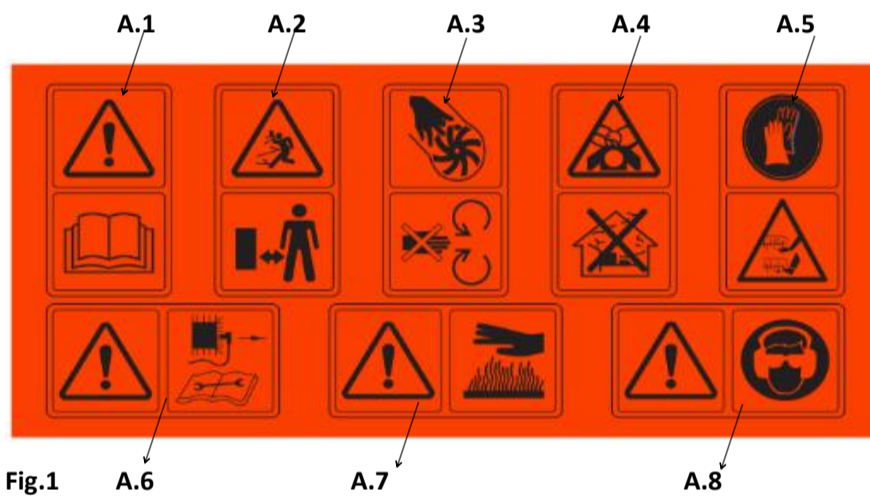

- A.1 Read the operating manual.
- A.2 Keep the bystanders away, **risk of projections.**
- A.3 Do not touch the rotating parts while operating.
- A.4 Toxic gases; do not operate inside the house.
- A.5 Please wear protective gloves; pay more attention to your hands and feet to avoid injury.
- A.6 When repairing, please pick up the spark plug and repair it according to the operation manual.
- A.7 Caution: The engine is hot.
- A.8 Wear glasses and earplugs to protect the operator.

## 3 ) Control mark

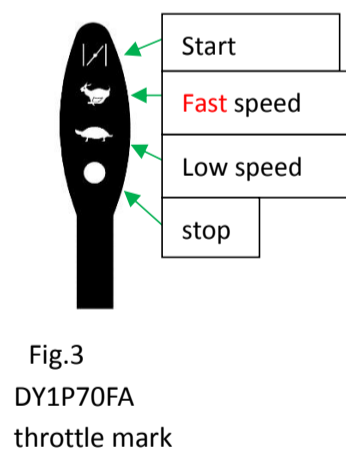

Fig.3  
DY1P70FA  
throttle mark

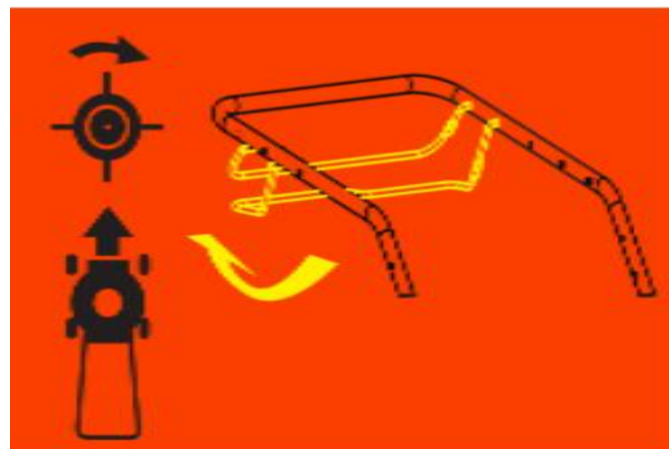

Fig.4.1  $\Delta$ Self-propelled drive tag

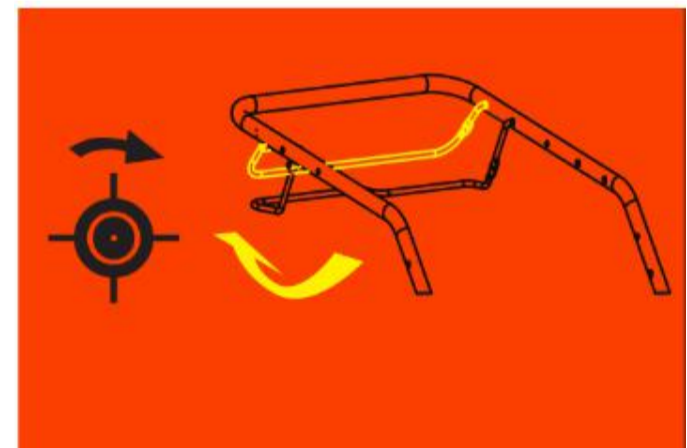

Fig.4.2  $\Delta$ Roller brush drive mark

## 4 ) Parameter mark



Fig.5.1 Self-propelled parameter marker



Fig.5.2 Hand push parameter marker

**5 ) LOGO mark**



Fig.6

## Chapter 2: Assembly instructions

● Your machine cannot be used immediately after it has been removed from the box. Please understand the name and function of each part on the second page of this manual, and then assemble it with the installation steps described in the following figure. Note: The shape of the part contained in the assembly diagram is not inconsistent with the actual part shape.

△ **Assembly step 1 ) Rear wheel drive lever assembly**—Install the wheel drive lever as directed by the diagram below (Please see Fig a-1, 2, 3)

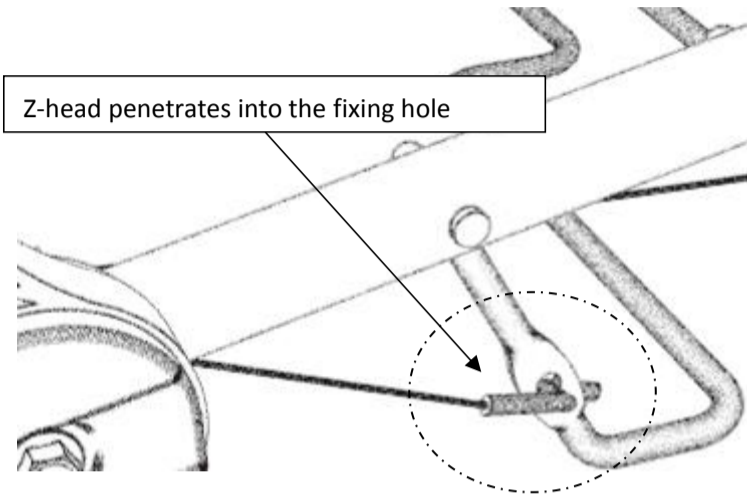

Fig.a-1

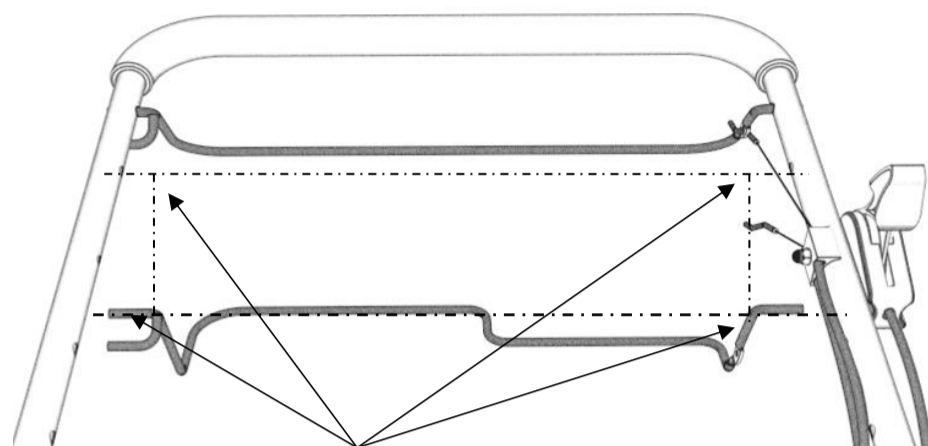

Fig.a-2

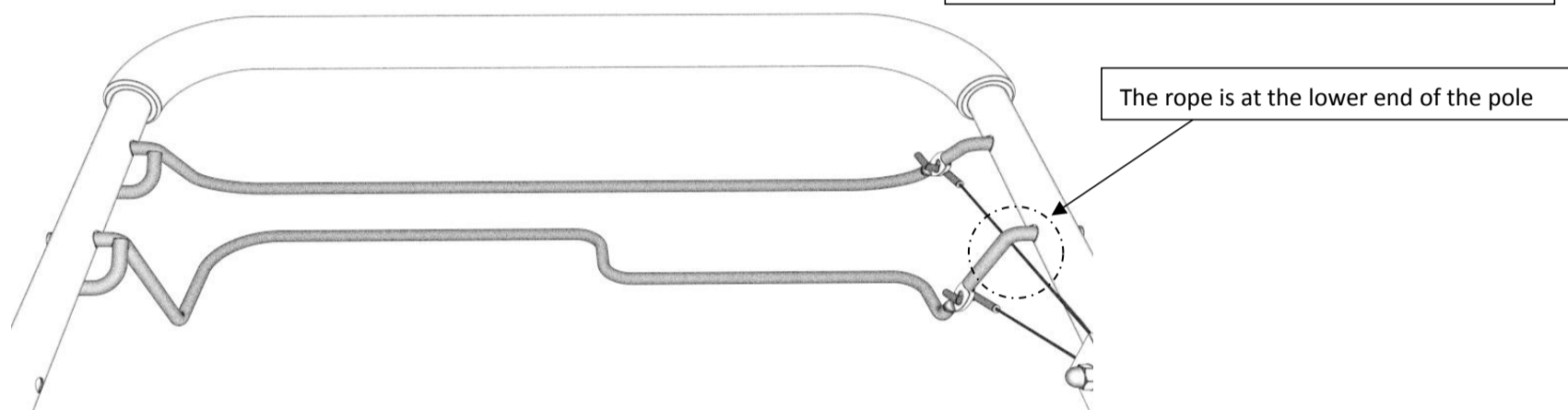

Fig.a-3

Assembly completion diagram

**Assembly step 2 ) Upper armrest assembly**—Please put the upper handrail bar assembly on the lower handrail bar, guide according to the dotted line, and then pass the two bolts through the mounting holes, and tighten the knob firmly.

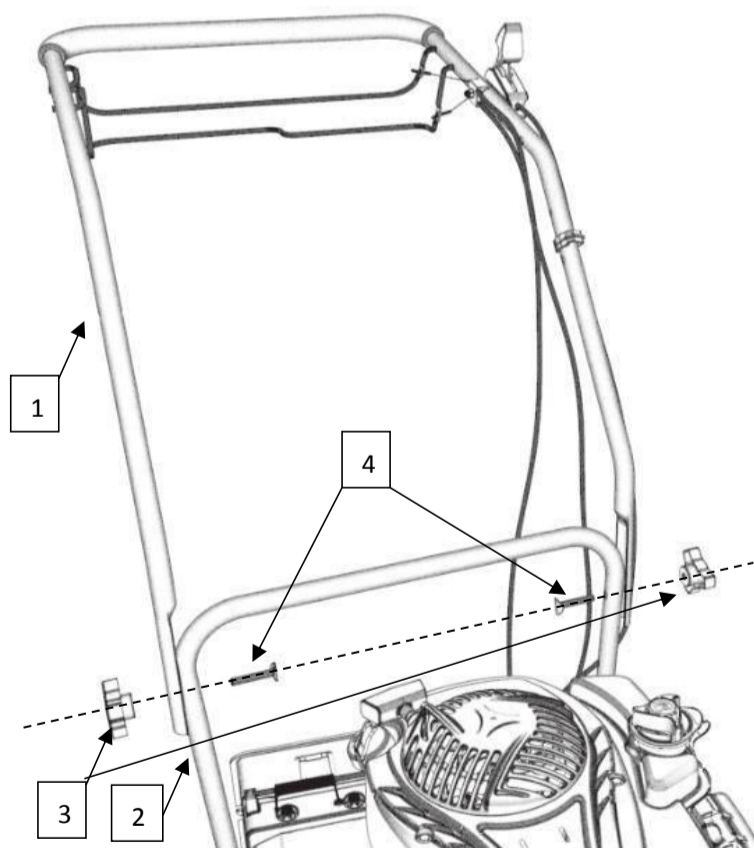

Fig.7-1

Assembly guide

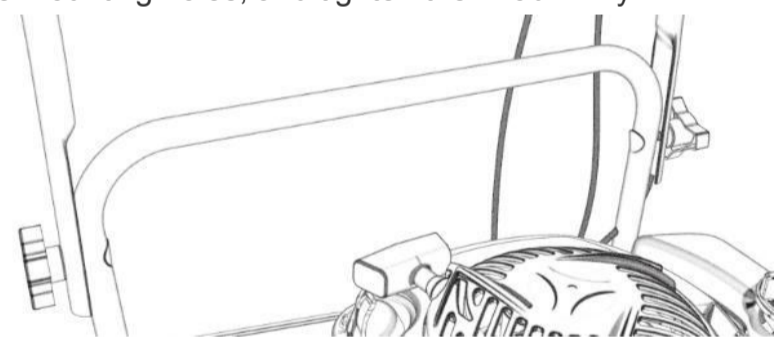

Fig.7-2 Assembly completion diagram

- Part 1——Upper grab bar assembly
- Part 2——Lower grab bar assembly
- Part 3——Knob M8
- Part 4——Semi-circular head square neck bolt M8X46



**Assembly 3 ) Collection bag fixing bracket assembly**—Insert the left and right ends of the collection bag fixing bracket into the corresponding four holes on the upper handrail bar assembly.

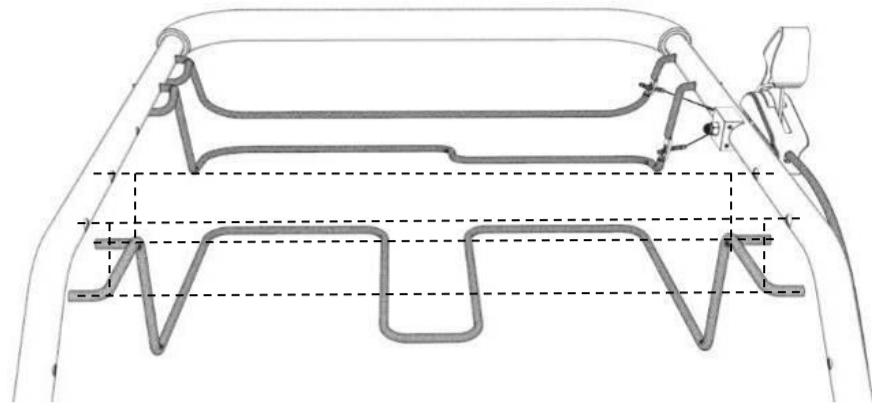

Fig.8-1 Assembly guide

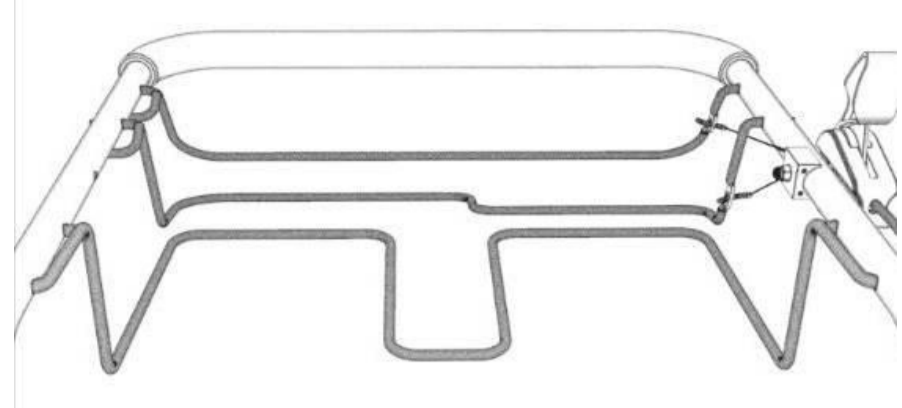

Fig.8-2 Assembly completion diagram

**Assembly step 4 ) Hose bracket assembly**—Insert the left and right ends of the hose bracket into the corresponding two holes on the upper grab bar assembly.

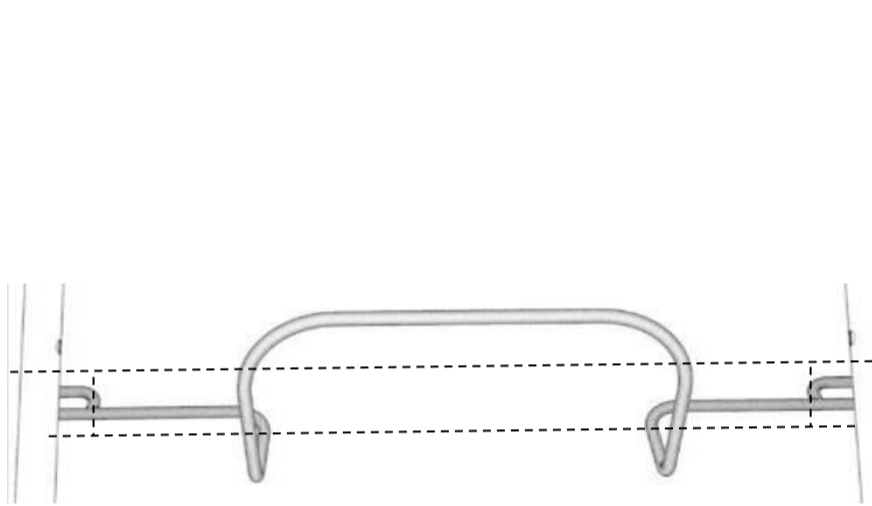

Fig.9-1 Assembly guide

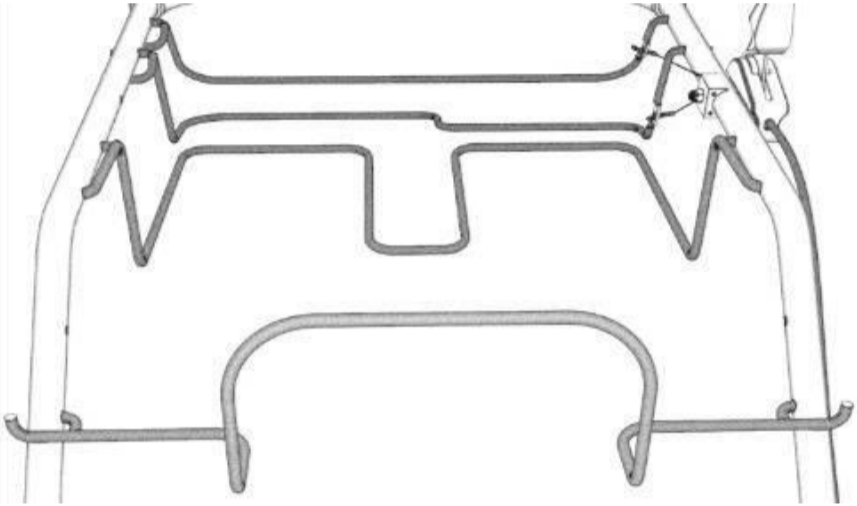

Fig.9-2 Assembly completion diagram

**Assembly step 5 ) Collection bag assembly**—Put the upper layer of the collection bag into the collection bag fixing bracket. The left and right clips are fastened to the bracket. Hang the two left and right hanging plates on the ends of the hose fixing bracket. Press the baffle and open the rear cover. Insert the collection bag interface into the back cover bracket.

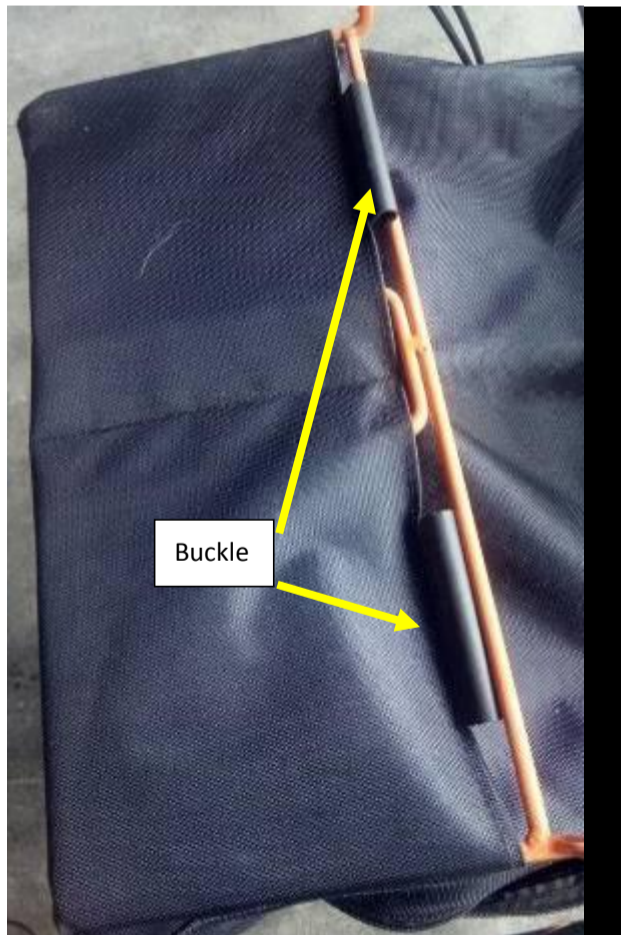



Fig.10-1 Nested into the collection bag

Fig.10-2 Fastening Card strip

Fig.10-3 Assembly hanging board



Fig.10-4



Fig.10-5 Press the baffle and open the rear cover



Fig.10-6 Insert back cover bracket



Fig.10-7 Insert in place



Fig.10-8 Installation completion diagram

△**Assembly step 6 ) Roller brush assembly**—Lift the suction port, pull the quick release trigger and open the quick release cover.

Align the square end of the roller brush into the square shaft, insert the bearing end into the quick-release bracket bearing mounting position, and pull the quick release trigger and fasten the upper cover.

⚠ **Note:** Before installing this component, it is necessary to turn off the machine engine to ensure that the entire machine is not working, replace or install the roller brush.

⚠ **Note:** The quick release cover must be snapped into place. Pull the roller brush firmly without pulling the trigger, please check if the roller brush will fall off; if it will fall, please reinstall this component.



Fig.11-1 Pull the trigger



Fig.11-2 Open the top cover

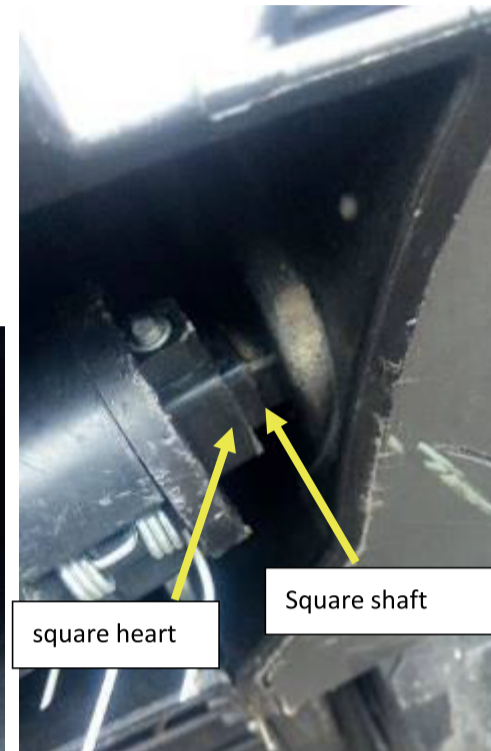

Fig.11-3 Insert square heart

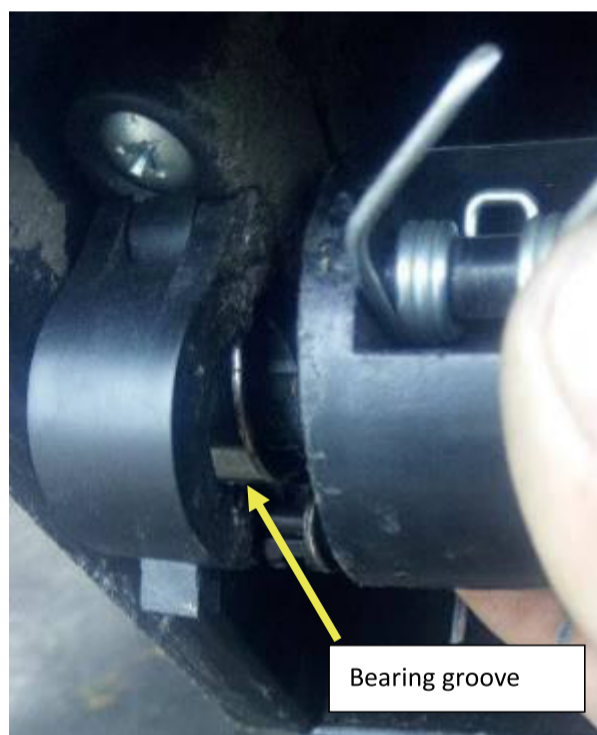

Fig.11-4 Snap in bearing



Fig.11-5 Fitting the cover



Fig.11-6 Installation completion diagram

△**Assembly step 7 ) Auxiliary hose assembly**—Open the cover on the suction port, align the end of the hose into the interface fixing bracket, and tighten it to the right according to the marking indication on the interface fixing bracket.



Fig.12-1 Open the cover



Fig.12-2 Insert hose connector



Fig.12-3 Screw the interface



Fig.12-4 Complete the installation diagram

△Assembly step 8 ) Placement of the suction port baffle—Barbs the baffle on the hose fixing bracket.

●Note: This is where the baffle is placed when the hose is not being used for suction.



Fig.13-1 Hanging baffle

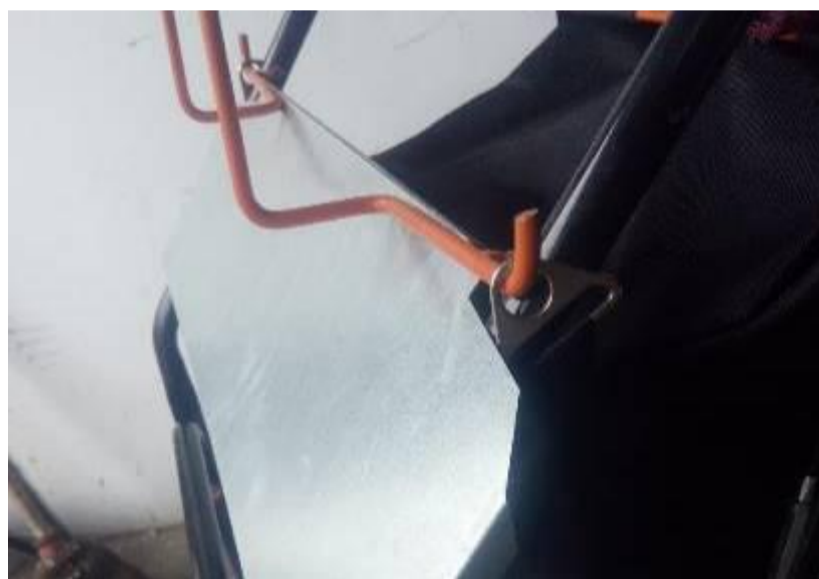

Fig.13-2 Installation completion diagram

△Assembly step 9 ) pulley assembly—Assemble the pulley according to the instructions in the diagram and tighten the nut.

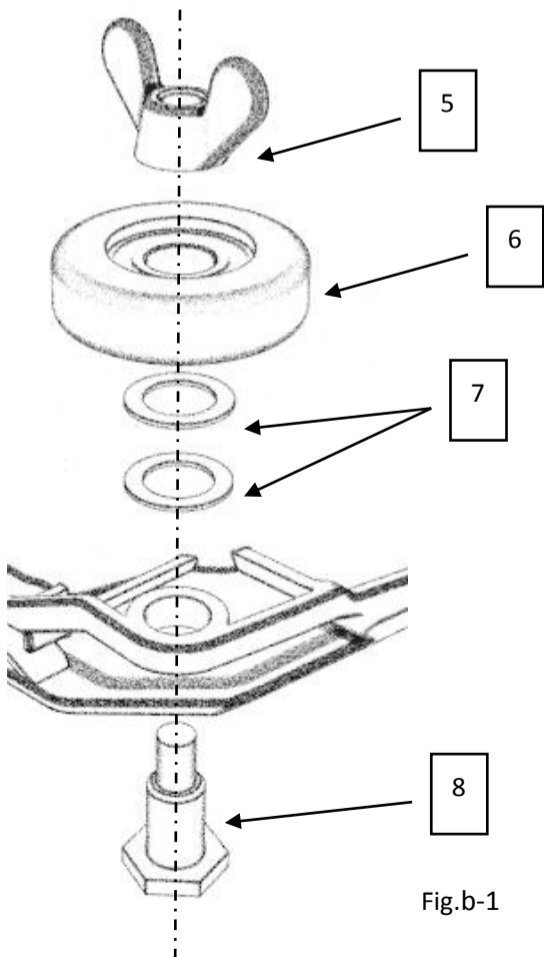

Fig.b-1

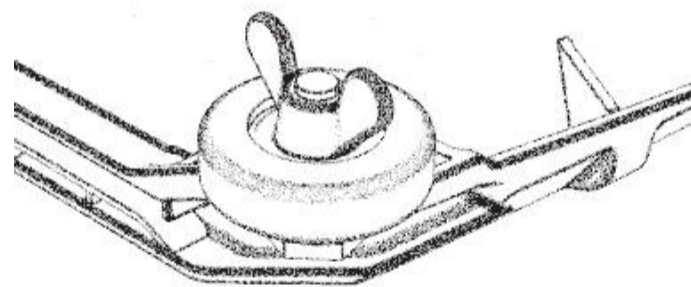

Fig.b-2 Right pulley installation completion diagram

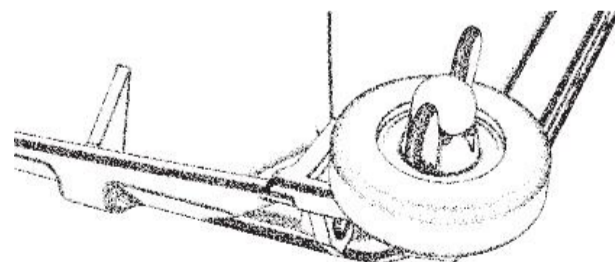



Fig.b-3 Left pulley installation completion diagram

part 5- Butterfly nut  
part 6- pulley  
part 7- washer  
part 8- fixed bolt

## Chapter 3: Product specification

### ●Host parameter

		
Machine model	<b>FAST175T-1</b>	<b>FAST175P-1</b>
engine	DY1P70FA	DY1P70FA
Engine power	<b>4 Kw</b>	<b>4 Kw</b>
Engine emissions	173 cm <sup>3</sup>	173 cm <sup>3</sup>
Fuel capacity	1.5 L	1.5 L
Oil capacity	0.6 L	0.6 L
Engine speed	3400 /min	3400 /min
Walking speed	3.4 km/h	
Collection bag capacity	150 L	150 L
Suction height	15mm-50mm	15mm-50mm
Suction air velocity	26 m/s	26 m/s
Air outlet speed	43 m/s	43 m/s
Guarantee the sound pressure level	86 dB(A) KpA=3dB(A)	86 dB(A) KpA=3dB(A)
sound power level	105 dB(A)	105 dB(A)
Vibration value	6.7 m/s <sup>2</sup> <b>K: 1,5m/s<sup>2</sup></b>	6.7 m/s <sup>2</sup> <b>K: 1,5m/s<sup>2</sup></b>
Working slope angle	Less than 20 degrees	Less than 20 degrees
Startup mode	throttle	throttle
Machine size	Length 1305mm X width 602mm X height 1080mm	Length 1305mm X width 602mm X height 1080mm
net weight	46.6 Kg	<b>42 Kg</b>
Gross weight	50 Kg	46 Kg

### ●Accessory parameters

	
Hose length	2500 mm
Pole telescopic length	730 mm-990 mm
Hose diameter	90 mm
Hose vacuumn - wind speed	40 m/s
Hose blowing - wind speed	46 m/s

## Chapter 4: Instructions for use

**⚠ Warning: Before reading the instructions for use, make sure you understand the above and keep it in mind.**

### 1 ) Start the machine

● Before starting, please check if the accessories you have assembled are completely fixed.

1. At the position of the marked organic oil label, turn on the oil dipstick and add the same amount of oil according to the oil capacity provided in the parameter table of this manual (page 11).
2. In the position marked with the fuel label, unscrew the fuel tank cap and add the same amount of gasoline according to the fuel capacity provided in the parameter table of this manual (page 11).

3. Make sure the microswitch rocker arm is closed. (See Fig 14-1, 2)



Fig.14-1 Switch rocker- Open state



Fig.14-2 Switch rocker- Closed state

4. Please pull the throttle handle to the start state. (See Fig 15-1, 2)



Fig.15-1 Throttle handle- Engine stop

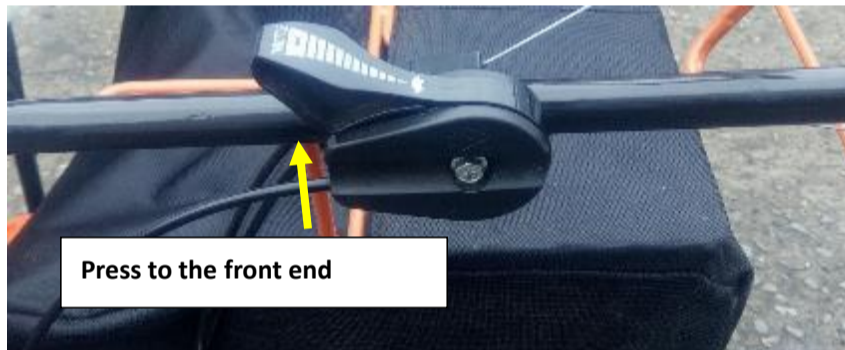

Fig.15-2 Throttle handle- Engine start

6. Pull the engine start handle to start the engine. (See Fig 17)

● Note: Before you pull the handle, please pay attention to your surroundings, Clean up items that are sharp and can hurt your arms.



Fig.17 Start the machine

6. Adjust the engine to the maximum speed. (see Fig 18-1, 2)



Fig.18-1 Throttle handle- Engine startup state

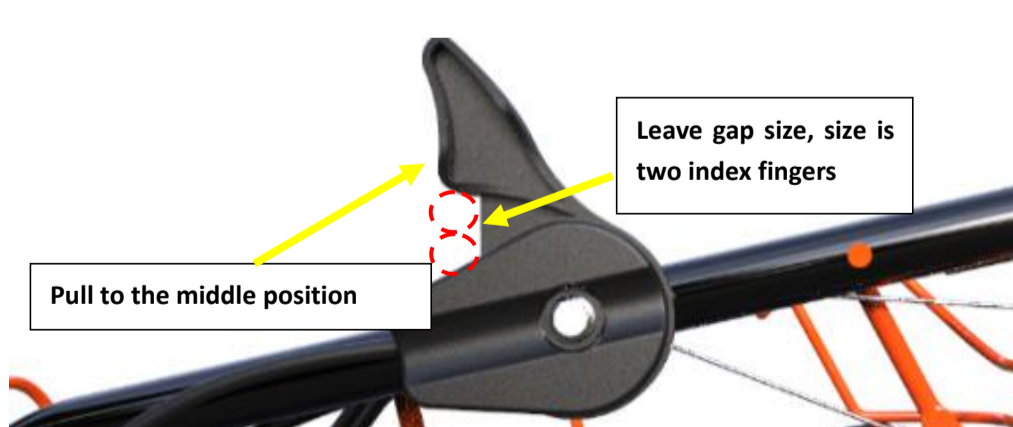

Fig.18-2 Throttle handle - Maximum speed status

### 2 ) Adjust the height of the suction inlet

1. Pull the height adjustment handle out of the gear position slot and provide the height adjustment range according to the parameter table of this

manual (page 11) and select one gear position adjustment height from the 5 gear positions according to your use area or situation. (See Fig 19-1, 2, 3)

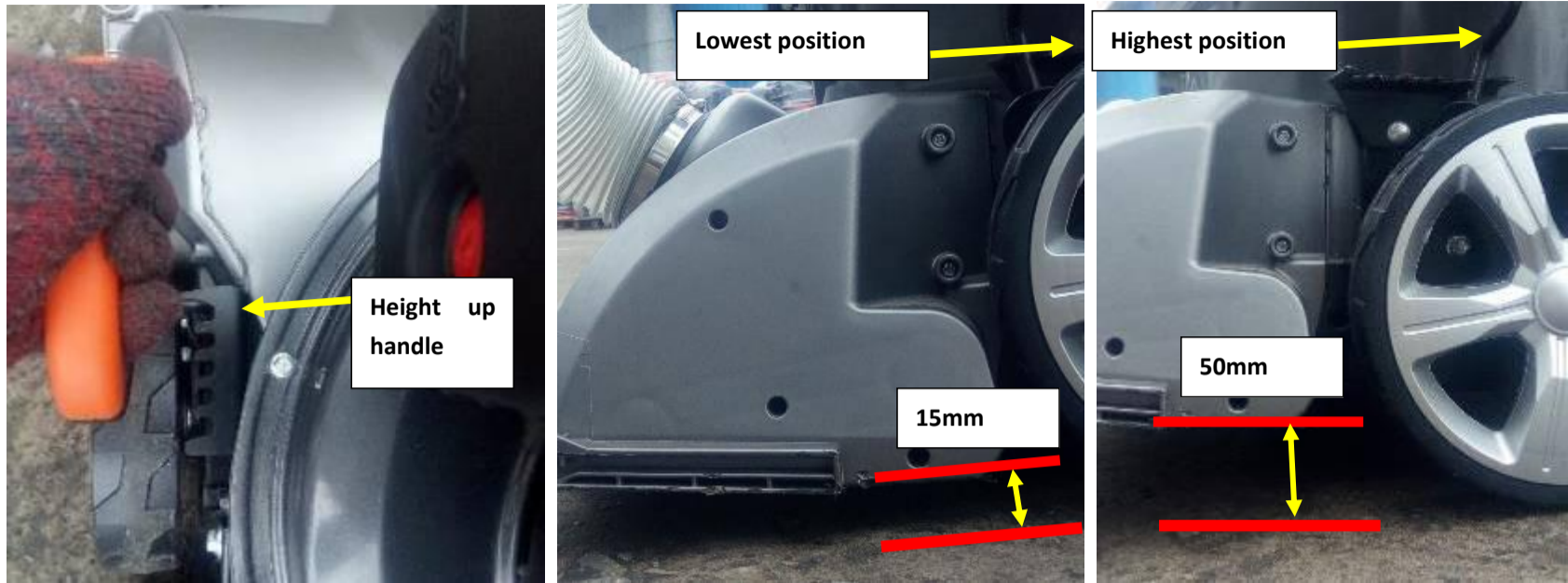

Fig.19-1 Pull out the handle

Fig.19-2

Height distance

Fig.19-3

Height distance

### 3) △The use and function of the guide wheel

1. During normal speed (3.4 km/h) travel, Impact at an angle of less than 45 degrees When striking road steps、 height exceeds (50mm-80mm) and fixed hard objects. The guide wheel will rub against the hard object, causing the direction of travel to change. Thereby avoiding the hard object and preventing the machine from being damaged by the violent impact of the hard object. (See Fig 20-1, 2)

● Note: Do not exceed the normal self-propelled speed (please provide self-propelled speed according to the parameter table of this manual (page 11)) and impact at an angle greater than 45 degrees. Such operation will cause the guide wheel to lose its function and cause the suction port to be damaged.

● Note: This function is an auxiliary function that protects the suction port for accidental impact. In normal times, please do not intentionally test its strength. Please concentrate on operating the machine, slow down in advance and change direction to avoid hard objects.

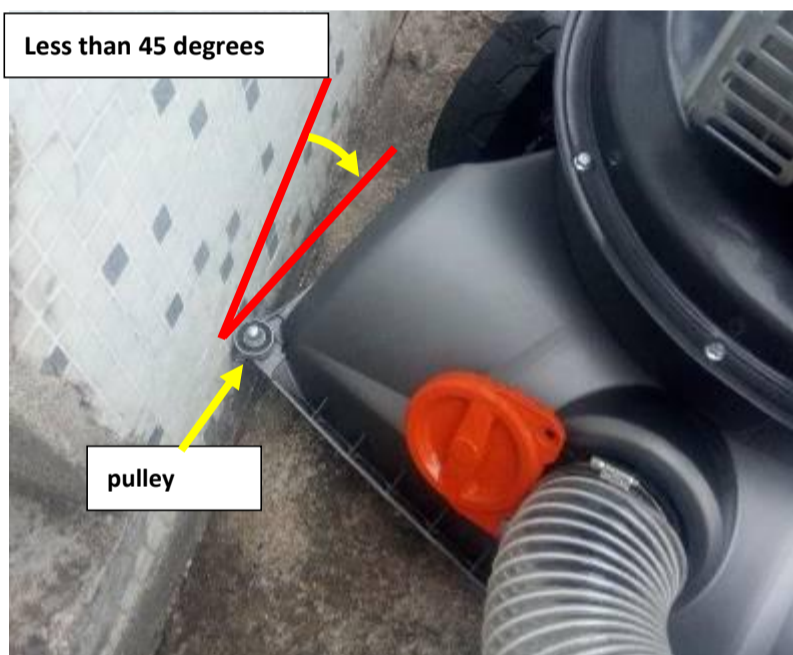

Fig.20-1

Impact angle



Fig.20-2

The role of the pulley

### 4) △Start and function of the roller brush

4) -1、 Start roller brush

1. Please assemble the roller brush disc according to the procedure in 'Assembly Instructions', Assembly Step 5) roller brush Assembly (page 9).

2. After starting the machine, close the roller drive lever. (See Fig 21-1, 2, 3, 4)

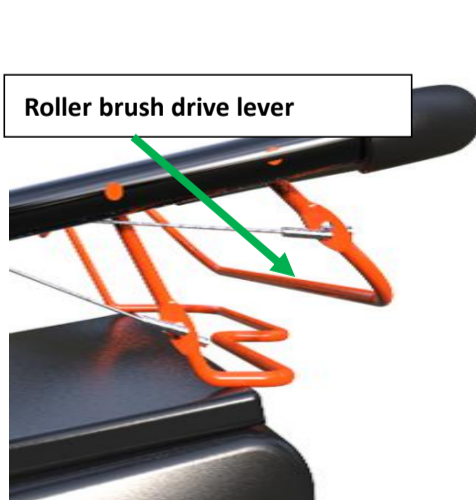

Fig.21-1



Fig.21-2

Pull rod closing direction



Fig.21-3

Clamping lever



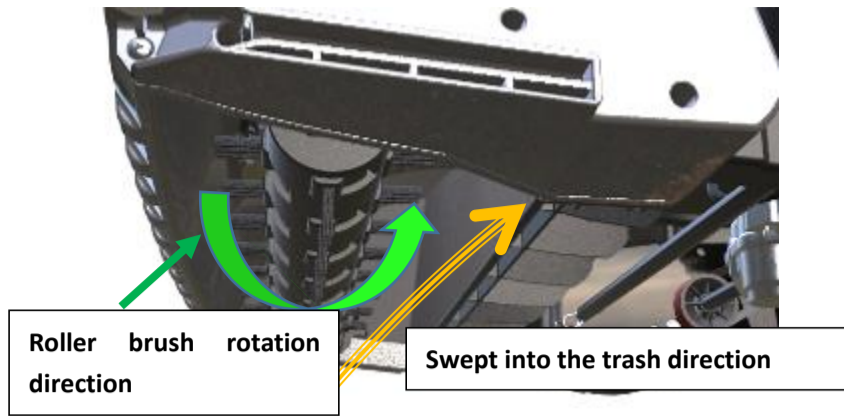

Fig.21-4 Working diagram

4) -2、 The role of Roller brush disk and the precautions for use

1. Roller brush disk is divided into Cleaning disk and Comb brush. (See Fig 22-1、 2)

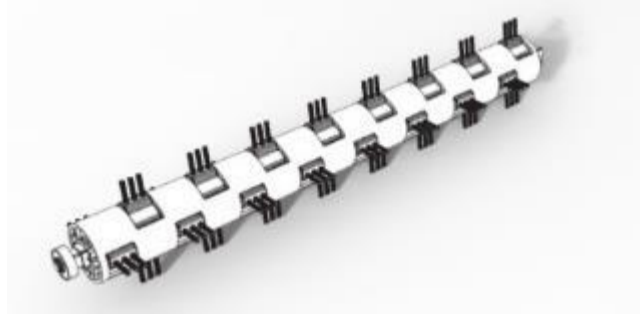

Fig.22-1 Sweepers

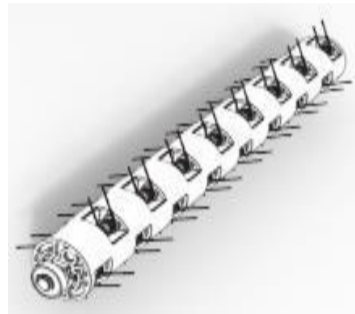

Fig.22-2 Comb brush

2. The role of Sweeping disc. When you encounter rubbish stuck on the ground, wet leaves stuck on the ground and difficult to handle, please use the Sweeping disc. Its brush does not damage the ground.

3. The role of Comb brush. On the lawn, please use the Comb brush; The steel claws attached to it will pick up the rubbish wrapped around the grass roots.

4. Precautions for the working area of the whole machine.

● Note: Do not use roller brushes or machines in harsh areas. (See fig 23-1、 2)



Fig.23-1 Very lush lawn



Fig.23-2 Very lush lawn

● Note: Do not use the machine to absorb soft fibers, fabrics. (See fig 24-1、 2、 3)



Fig.24-1 plastic rope

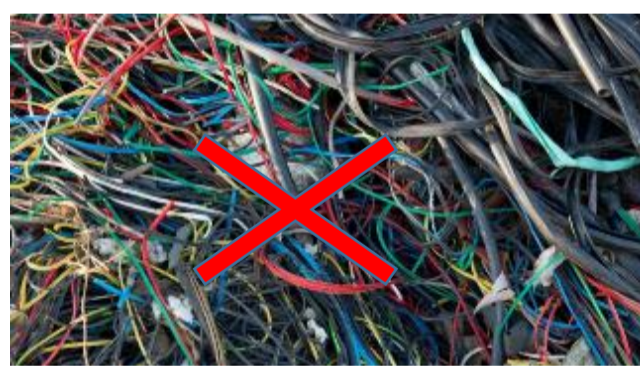

Fig.24-2 Banded fibrous material



Fig.24-3 Plastic bag

● Note: Do not work the machine in a garbage dump. (See Fig 25)



Fig.25 Garbage accumulation area

● Note: Do not try to absorb larger trash. (See Fig 26)



Fig.26 Large trash

5. Reasonable work area

● Ground and lawn covered by fallen leaves. (See Fig 27-1, 2)



Fig.27-1 Fallen leaves on the lawn



Fig.27-2 Fallen leaves on the lawn

● Ground and lawn with more leaves(Please see the picture 28-1, 2)



Fig.28-1 Fallen leaves on the road surface



Fig.28-2 Scattered garbage on the road

5 ) △self-propelled operation instructions

1. After starting the machine, first close the roller brush drive lever and then close the self-propelled drive lever. (See Figure 29-1, 2, 3)

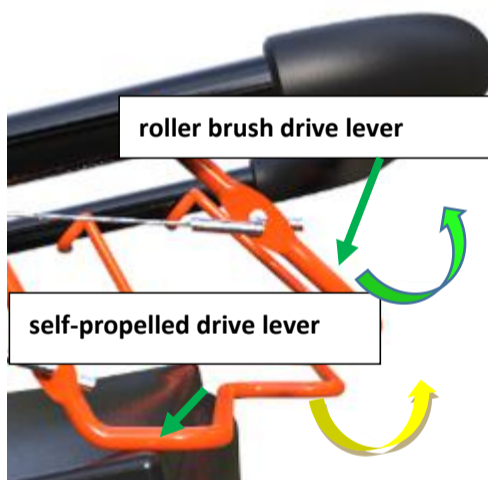

Fig.29-1 Pull rod closing direction



Fig.29-2 Clamping lever

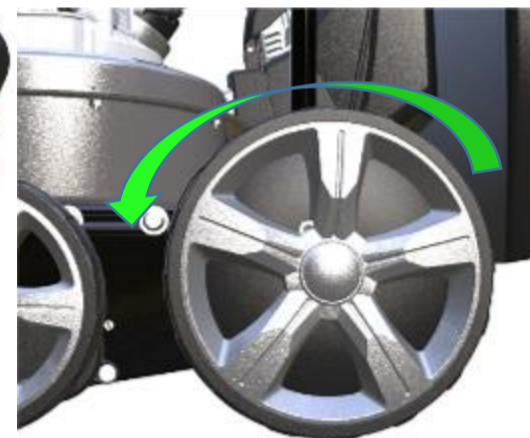

Fig.29-3 Wheel rotation direction

6 ) △Auxiliary hose instructions for use

6) -1. Auxiliary hose function—Vacuum function

1. Please assemble the auxiliary hose according to the steps in the assembly instructions "Assembly Step 6" Auxiliary Hose Assembly" (page 9-10).

2. Insert the suction port baffle into the suction port. (see fig 30-1、 2)



Fig.30-1 Insert baffle



Fig.30-2 The baffle is inserted into place

3. Start the machine, Point the hose mouth at the trash. (see fig 31)

●Note: When loading and unloading the hose, please turn off the engine first.

●Note: The suction port baffle is only used when the auxiliary hose is vacuumed.



Fig.31 Using a hose

6) -2. Auxiliary hose function—Telescopic function

1. Telescopic tube can adjust the height of different handle positions

2. Push the Lock with your thumb while adjusting the handle position forward or backward. (See Fig 32-1, 2)



Fig.32-1 Push open the lock



Fig.32-2 Adjust the telescopic height

6) -2. Auxiliary hose function—Blow function

1. Close the rear cover (see fig 33-1、2、3)



Fig.33-1 Close the rear cover



Fig.33-2 Close completely



Fig.33-3 The switch rocker arm is fully closed

- Note: When using this function, please turn off the machine.
- Note: When fully closed, check that the rear panel bezel securely locks the rear cover.
- Note: When fully closed, please check if the switch rocker arm has been closed by the rear cover
- Note: It is strictly forbidden to remove the auxiliary hose when the machine is working.

2. Attach the auxiliary hose tail connector to the rear cover hose connector. (See Fig 34-1, 2)



Fig.34-1 Open the cover

3. Start the machine, Point the hose mouth at the trash. (see fig 35)



Fig.35 Using a hose



Fig.34-2 Fixed interface

6) -3. Auxiliary hose use precautions.

1. Please understand in detail the operation according to the "Precautions for the working area of the whole machine (pages 14-15)" and the following precautions.

- Note: Please understand the parameters of the auxiliary hose in "Accessory Parameters (page 14)" before use.
- Note: When working, try to straighten the hose and work it to ensure maximum suction and wind speed.
- Note: It is strictly forbidden to point the hose to others or any non-working area during work.
- Note: It is strictly forbidden to load and unload the hose interface when the machine is started. .
- Note: Do not pull the hose to move the machine forward or backward.
- Note: Do not align the hose head with liquids, fire, and hazardous gases.
- Note: Do not pick up the trash that is larger than the hose port.
- Note: When the hose is clogged, stop the machine and then maintain it.
- Note: Keep the hose away from the engine silencer.

7) Instructions for using the collection bag

1. Please assemble the collection bag according to the steps in the assembly instructions "Assembly Step 4" Collection Bag Assembly" (page 7-8).
2. During the use of the machine, the dust inhaled by the machine may cause the venting holes of the collecting bag to become clogged or cause the air to return when the collecting bag is full. At this time, please open the exhaust window zipper to make the collection bag ventilate; or check if the collection bag is full. (See Fig 36-1, 2, 3)。

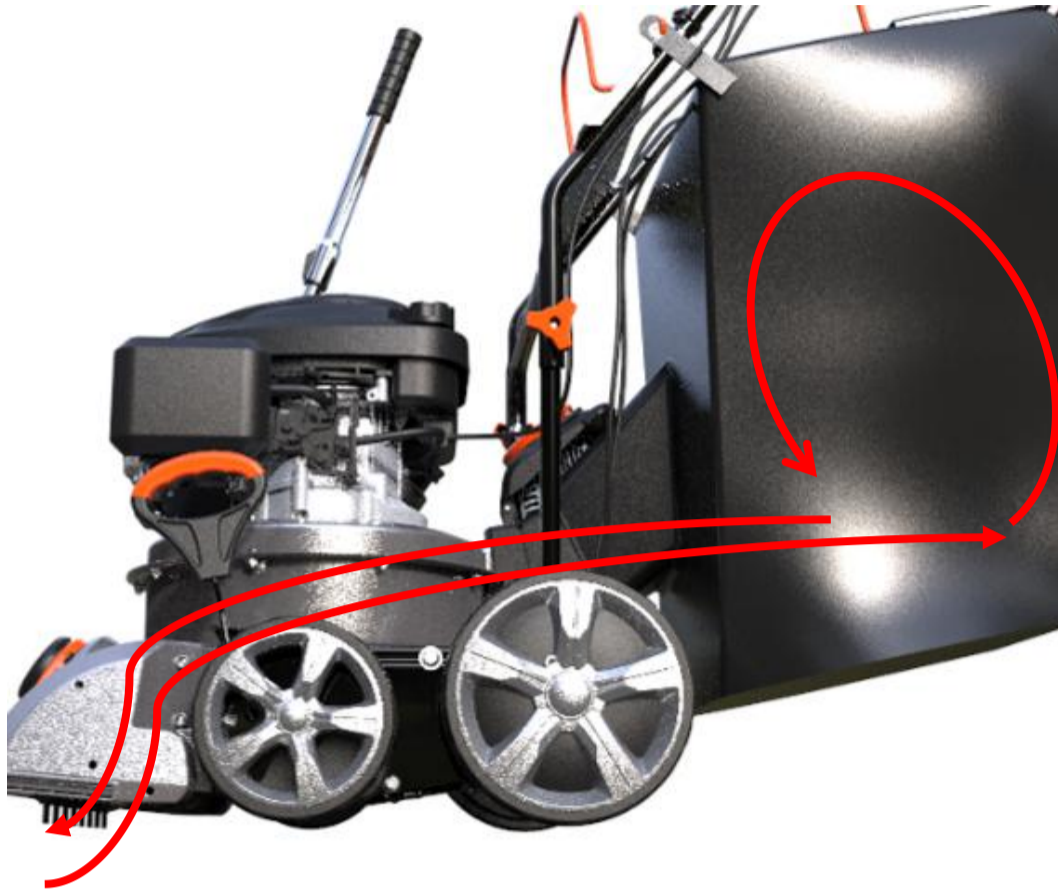

Fig.36-1 Reflux



Fig.36-2 Open zipper



Fig.36-3

3. When the collection bag is full, stop the machine; remove the collection bag and dump the garbage. (see fig 37-1、2、3、4、5、6)



Fig.37-1  
Take down the bag interface



Fig.37-2  
Remove the collection bag hanging plate



Fig.37-3  
Remove the collection bag



Fig.37-4  
Open the collection bag mouth



Fig.37-5  
Open the collection bag mouth



Fig.37-6  
Pour out the garbage in the collection bag

#### 4. Collection bag precautions

- **Note** : 1. When encountering backflow, please check if the venting hole of the collecting bag is blocked ;
- 2. Whether the collection bag is full ;
- 3. Stop the machine and check if the collection bag interface is block.
- **Note**: When loading and unloading the collection bag, please make sure the machine has been turned off.

● **Note**: Before starting the machine, please check if the collection bag mouth is closed.

● **Note**: It is strictly forbidden to open the collection bag mouth when the machine is working.

● **Note**: When cleaning the collection bag, do not tap the collection bag with a tool.

#### 8 ) Stop the engine.

Please understand the individual indications of the throttle marks in the "Control Marks (page 5)".

1. Move the throttle handle to the flameout position. (see fig 38)



Fig.38 Handle off position

## Chapter 5: Lubrication instructions

---

**Note: Stop the engine before maintenance.**

**1. The ball bearings, gears and shafts on each wheel must be lubricated once with oil.**

● **Note: When moving, when the gears and bearings are abnormal, you should stop and prepare to add grease.**

**2. Obtain lubrication instructions according to the engine manual.**



Fig.39-1 Add grease to the gear



Fig.39-2 Add grease to the output shaft

## Chapter 6: Engine description

---

See the separate engine manual for engine maintenance instructions.

Maintain engine oil as described in the engine manual that came with the unit.

Please read and follow the instructions carefully.

Under normal conditions, please maintain the air filter in accordance with the separate engine manual; clean it every few hours under extremely dusty conditions. When the engine is not performing well or after being invaded by water, the air filter and carburetor should normally be repaired.

To service the air filter, refer to the engine manual supplied with the unit.

It is recommended to replace the spark plug or check the spark plug at the beginning of each machine season. Please refer to the engine manual for the correct plug type and clearance specifications.

Clean the engine regularly with a cloth or brush. Keep the cooling system (blower housing area) clean to allow proper air circulation, which is critical to engine performance and life. Always remove all grass, dirt and combustible waste from the muffler area.

## Chapter 7: Machine cleaning and storage

---

Proper cleaning and storage are critical to keeping your machine trouble-free and in good condition. The following steps will help prevent rust and corrosion impair the function and appearance of the machine, and will make the engine easier to start when you use the machine again.

### 1) cleaning

#### **1. Cleaning machine**

Clean engine

● Manually clean the engine and take care to prevent water from entering the air filter.

- Using garden hoses or pressure washers can cause water to enter the air purifier. The water in the air filter will soak the filter and enter the carburetor or engine and cause damage.

- Water on the hot engine can cause engine damage. If the engine is already running, let it cool for at least half an hour before cleaning.

● Make sure the fuel valve is in the closed position before cleaning the housing of the machine platform. Disconnect the spark plug cap. Turn the machine sideways so that the air filter is facing up. This will help prevent fuel leakage and hard start caused by carburetor overflow.

● Wear thick gloves to protect your hands from the blade.

Cleaning collection bag

● Remove the collection bag from the machine and wash it with a garden hose or high pressure cleaning equipment. Allow the bag to dry completely before storing.

**2. After cleaning the machine, wipe all accessible surfaces.**

**3. Start the machine outdoors and run it until it reaches the normal operating temperature to evaporate the water remaining on the engine.**

**4. Stop the engine and allow it to cool.**

**5. After the machine is clean and dry, cover the damaged paint surface and any other areas that may rust with a thin oil film. Lubricate the control cable with a silicone spray lubricant.**

## 2 ) storage

● The following steps should be taken to prepare the machine for storage.

1. Empty the fuel tank after use in the last quarter.

a) Empty the fuel tank with a suction pump.

⚠ Be careful! Do not discharge gasoline in a closed room or near an open flame. do not smoke! This can cause an explosion or fire.

b) Start the engine and let it run until it runs out of all remaining gasoline.

c) Remove the spark plug. Approximately 20 ml of oil was injected into the combustion chamber using a syringe. Pull the starter disk to evenly distribute the oil in the combustion chamber.

2. Clean and lubricate the machine carefully as described in the Lubrication Instructions above.

3. Gently apply the rust inhibitor to the impeller and exposed metal parts to avoid corrosion.

4. Store the machine in a dry, clean, frost-proof place away from unauthorized personnel

⚠ Be careful! The engine must be completely cooled before storing the machine.

## Chapter 8: Machine maintenance instructions

### 1 ) The importance of proper maintenance

● Proper maintenance is critical to safe, economical and trouble-free operation; it also helps reduce air pollution.

⚠ Improper maintenance or failure to correct problems prior to operation can result in serious injury or death.

● Always follow the maintenance recommendations and schedules in this instruction manual.

To help you properly maintain your machine, the following pages include maintenance plans, routine inspection procedures, and simple maintenance procedures using basic hand tools. Other maintenance tasks that are more difficult or require special tools are best handled by professionals, usually by our technical staff or other qualified mechanics.

The maintenance plan is for normal operating conditions. If you operate the machine under harsh conditions, such as continuous high load or high temperature operation, or in unusually humid temperatures, consult your service dealer for advice that is appropriate for your individual

needs and use.

**Maintenance, replacement or repair of the emission control devices and systems can be performed by any engine service facility or individual using components that meet the EPA standards in the "Certification".**

### 2 ) Maintenance safety

We cannot warn you of the dangers that can arise when performing maintenance. Only you can decide if you should perform the given situation.

### 3 ) Safety instructions

● Make sure the engine is off before starting any maintenance or repairs.

### 4 ) Routine maintenance

#### 1. Oil maintenance

Before each use of the machine, check the oil level to see if it is between the upper and lower scales of the oil gauge (see Fig 39-2). The new machine is run for 4 hours before use to achieve the best effect of the machine. After the running-in period, please replace the oil. The oil should be replaced after 25 hours of use, and the oil should be changed periodically according to the instructions.

The oil change should be carried out after the engine is in the heat engine. Do not add too much oil, otherwise it will appear: black smoke, no power (excessive cylinder carbon deposit, small spark plug clearance). Engine overheating. Filling the engine oil should not be too small, otherwise it will appear: the engine gear is noisy, the piston ring accelerates wear and damage, and even the piston jams, causing serious damage to the engine. When changing the oil, the machine must be tilted in the direction of the oil port, you can pour it out and replace it with new oil, but you can't tilt it to the other side. Otherwise, the oil will flow into the carburetor, causing damage to the carburetor.

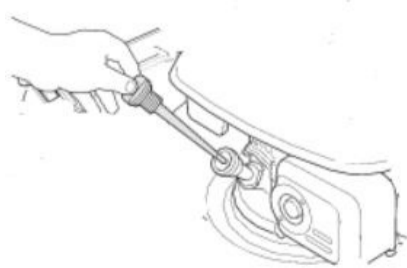

Fig.39-1 Take out the dipstick

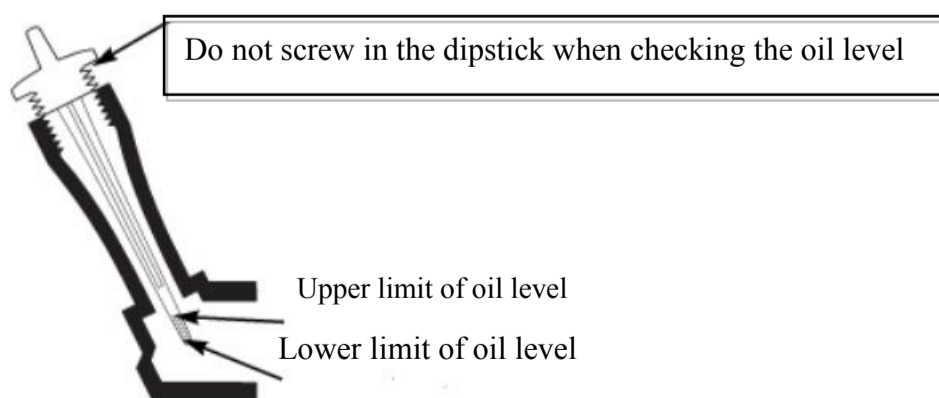

Fig.39-2 Measuring oil level

#### 2. Air filter maintenance

Check the air filter for dirty before and after each use. If it is too

dirty, it will cause the engine to start hard, black smoke, and no power. If the filter element is paper, remove the filter element and remove the dust attached to it; If the filter element is made of sponge, after cleaning with gasoline, apply some lubricating oil on the filter element to keep the filter element moist, which is more conducive to dust absorption. However, the other layer surrounded by the sponge cannot be washed with water. After washing, it will cause the pores to close and affect the engine work (the inner layer is made of paper). When cleaning, use an air gun to blow it clean.



Fig.40-1 Open the air filter side cover



Fig.40-2 Take out the filter



Fig.41 Fuel tank cap

### 3. Radiator maintenance

The main function of the radiator is to eliminate noise and heat. When the machine is working, the sundries may be covered on the heat sink, affecting its heat dissipation function. In severe cases, the engine may be damaged. Therefore, after each use of the machine, the debris on the heat sink should be carefully cleaned.

### 4. Fuel maintenance

Every time the fuel is exhausted, the machine should be allowed to rest for ten minutes before refueling. Otherwise, the fuel will be on fire due to the high temperature of the machine. When refueling, please add the same amount of fuel according to the fuel capacity in the “Host Parameters (page 11)”; if you add too much oil, it will block the vent hole on the oil cover, causing the oil level to be free from pressure and unable to supply oil to the engine.

## Chapter 9: Maintenance planning cycle

cycle category		Before each use	After each use	Every 10 hours	Every 25 hours Or every quarter	Before storage	Remarks	date
machine	Check parts	●				●		
	Cleaning collection bag	●	●			●		
	Cleaning machine		●			●		
	Check/replace roller brush	●Check	●Check			●Check	Replace according to the degree of damage	
	Check/replace belt				●Check		Replace according to the degree of damage	
	Clean air duct	●	●			●		
	Check / clean / replace the impeller	●clean	●clean			●clean	Replace according to the degree of damage	
	Check/replace pulley				●Check		Replace according to the degree of damage	
	Inspection / clean / lubrication self-propelled device	●clean	●clean		●lubrication	●clean、lubrication	Clean foreign objects on the shaft	
engine								
	Check the oil	●				●		
	Check fuel					●		
	Change the oil (viscosity 10w-30)				●		Increase maintenance frequency according to usage environment	
	Cleaning air filter			●			Increase maintenance frequency according to usage environment	
	Check/replace spark plug				●			
	Replace the air filter				●		According to the dirty degree of the filter	
Check silencer				●		Increase maintenance frequency according to usage environment		



## Chapter 10: Troubleshooting and solutions

problem	possible reason	Corrective Action	Priority
Engine cannot start	Throttle wrench is not in the correct position	Move the throttle choke to the correct position	
	There is no fuel in the fuel tank	Add the same amount of gasoline according to the fuel volume provided in the parameter table of this manual (page 11).	
	Air filter components are dirty	Clean air purifier components	√
	Spark plug loose	Screw the spark plug to 25-30Nm	
	The spark plug wire is loose or disconnected from the plug	Install spark plug wire on spark plug	√√
	Spark plug gap is incorrect	Set the gap between the electrodes to 0.7 to 0.8 mm	
	Spark plug is defective	Install a new spark plug	
	Carburetor flooded with fuel	Remove the air filter element and pull the starter rope continuously until the carburetor cleans itself and installs the air filter element.	√√√
	Ignition module failure	Contact service agent repair	
	Switch rocker arm is not closed	Close the switch rocker arm as shown in Fig15-1, 2 on page 12.	√√√
	The throttle handle is not pulled to the starting position	Move the throttle handle to the starting position, as shown in Figure 15-1, 2 on page 12.	√√√
The engine is difficult to start or lose power	There are impurities in the fuel	Reclean the tank and use new fuel	
	The fuel filter is blocked by impurities	Clean the filter	√√
	The air intake hole on the fuel tank cap is blocked	Clean or replace the fuel tank cap	√√√
	Air filter components are dirty	Clean air purifier components	√
Unstable engine speed	Spark plug is defective	Install a new spark plug	
	Spark plug gap is incorrect	Set the gap between the electrodes to 0.7 to 0.8 mm	
	Insufficient fuel supply	Check for carburetor or strainer for impurities	√√
	Air filter components are dirty	Clean air purifier components	√√
The engine idling is very poor.	Air filter components are dirty	Clean air purifier components	√√
	Air slots in the engine shroud are blocked	Clear debris from the slot	
	The fins and air passages under the engine blower housing are blocked.	Remove debris from the heat sink and air passage	
The engine has no high speed.	The gap between the spark plug electrodes is too close	Set the gap between the electrodes to 0.7 to 0.8 mm	
Engine overheating	Cooling airflow is limited	Check the fan for damage or blockage by debris, clear any debris in the slots in the air passage	√
	Spark plug is incorrect	Install a new spark plug	
Abnormal vibration of the machine	Impeller bolt loose	Tighten the impeller bolts	√
	Impeller is out of balance	Balance or replace the new impeller	√√√
Abnormal noise occurs when the machine starts up	Boot disk loose	Fix the boot disk	√√
	There is debris in the suction port	Remove debris from the suction vent	
	Foreign matter is attached to the connecting shaft below the impeller	Clear foreign objects on the connecting shaft	
	The impeller is wrapped by foreign matter	Remove foreign matter from the impeller	√√√
	Impeller bolt loose	Tighten the impeller bolts	
	Impeller is out of balance	Balance the impeller or replace the new impeller	√√
Engine can't turn off	The flameout line has fallen off	Reinsert the flameout line	√
	Flameout switch contact is damaged	Contact service agent repair	√√√
	Igniter damage	Contact service agent repair	
Unable to absorb garbage	The suction port is blocked by debris	Remove debris from the suction vent	√
	Collecting bag vent hole is blocked by dust	Cleanup collection bag or open vent window zipper	√√√
	Collection bag full	Clean up the garbage in the collection bag	√√
Machine walking is	Foreign substance is wound on	Clean up foreign objects on the wheels	

difficult	wheels		
	The ground is uneven	Adjust the height to the appropriate gear	√
	The lawn is very lush	Adjust the height to the appropriate gear	√√√
	Collection bag full	Clean up the garbage in the collection bag	
Self-propelled is very difficult	Self-propelled failure	Contact service agent repair	
	Clutch belt damage	Replacement belt	
	Clutch belt is not on the pulley	Reinstall the belt	
	Clutch belt wear	Adjust the tension	√√√
	Self-propelled clutch pulley damage	Replace the clutch pulley	√
	Self-propelled driven pulley damage	Replace the driven pulley	
	The internal teeth of the wheel are worn	Replace the new self-propelled wheel	√√
	Tensioner damage	Replace the new tensioner	
	Rear axle distortion	Corrected rear axle head	√
Roller brush stop rotation	Self-propelled failure	Contact service agent repair	
	Roller brush drive belt damage	Replacement belt	√
	The timing belt is damaged	Replace the timing belt	
	Synchronous pulley damage	Replace the timing belt pulleys	
	The Roller brush is entangled by foreign objects	Cleaning roller brush	√√√
Auxiliary hose suction function is invalid	The inside of the hose is blocked	Dredge hose	
	The suction port baffle is not inserted in place	Insert the bezel into place	√√√
Auxiliary hose blowing function is invalid	The inside of the hose is blocked	Dredge hose	
	The suction port baffle is not unloaded	Unload the bezel	√

## **Chapter 11: Environmental protection**

---

Should your machine need replacement after extended use, do not put it in the domestic waste but dispose of it in an environmentally safe way.

## Chapter 12: Declaration of conformity

---

### EC- Declaration of Conformity

**BUILDER SAS**  
32 Rue Aristide Bergès, 31270 CUGNAUX - FRANCE

declare that the following Appliance complies with the appropriate basic safety and health requirements of the EC Directives (see item 4) based on its design and type, as brought into circulation by us.

This declaration relates exclusively to the machinery in the state in which it was placed on the market, and excludes components which are added and/or operations carried out subsequently by the final user.

Designation/ function: Gasoline powered garden blower vacuumms/pick up debris into the debris collector or blow debris

References FAST175T-1/FAST175P-1

Serial number: 20201127364-20201127393  
20201127394-20201127423

Applicable EC Directives: Machinery Directive 2006/42/EC

Used harmonized Standards:  
EN 15503:2009+A2:2015, EN ISO 12100:2010, EN ISO 3744:1995, ISO 11904:1991, EN ISO 14982:2009

Responsible for documentation: Olivier PATRIARCA

Additional used EC Directives:  
- EMC Directive 2014/30/EU  
- Outdoor- Noise- Directive 2000/14/EC  
- Emission directive (EU) 2016/1628 & 2018/989/EU

Measured sound power level 86.0 dB (A) K: 3dB(A)

Guaranteed sound power level 105 dB (A)

Conformity assessment method to Annex V/ Directive 2000/14/EC & 2005/88/EC

Date /Name/ Authorized Signature/Place:

Cugnaux, 08/21/2020

Philippe MARIE





### WARRANTY

The manufacturer guarantees the product against defects in material and workmanship for a period of 2 years from the date of the original purchase. The warranty only applies if the product is for household use. The warranty does not cover breakdowns due to normal wear and tear.

The manufacturer agrees to replace parts identified as defective by the designated distributor. The manufacturer does not accept responsibility for the replacement of the machine, in whole or in part, and/or ensuing damage.

#### **The warranty does not cover breakdowns due to:**

- insufficient maintenance.
- abnormal assembly, adjustment or operations of the product.
- parts subject to normal wear and tear.

#### **The warranty does not extend to:**

- shipping and packaging costs.
- using the tool for a purpose other than that for which it was designed.
- the use and maintenance of the machine done in a manner not described in the user manual.

Due to our policy of continuous product improvement, we reserve the right to alter or change specifications without notice. Consequently, the product may be different from the information contained therein, but a modification will be undertaken without notice if it is recognized as an improvement of the preceding characteristic.

#### **READ THE MANUAL CAREFULLY BEFORE USING THE MACHINE.**

When ordering spare parts, please indicate the part number or code, you can find this in the spare parts list in this manual. Keep the purchase receipt; without it, the warranty is invalid. To help you with your product, we invite you to contact us by phone or via our website:

- **+33 (0)9.70.75.30.30**
- **<https://services.swap-europe.com/contact>**

You must create a "ticket" via the web platform.

- Register or create your account.
- Indicate the reference of the tool.
- Choose the subject of your request.
- Describe your problem.
- Attach these files: invoice or sales receipt, photo of the identification plate (serial number), photo of the part you need (for example: pins on the transformer plug which are broken).



### WHAT TO DO IF MY MACHINE BREAKS DOWN?

#### **If you bought your product in a store:**

- a) Empty the fuel tank.
- b) Make sure that your machine is complete with all accessories supplied, and clean! If this is not the case, the repairer will refuse the machine.

Go to the store with the complete machine and with the receipt or invoice.

#### **If you bought your product on a website:**

- a) Empty the fuel tank.
- b) Make sure that your machine is complete with all accessories supplied, and clean! If this is not the case, the repairer will refuse the machine.
- c) Create a SWAP-Europe service ticket on the site: <https://services.swap-europe.com> When making the request on SWAP-Europe, you must attach the invoice and the photo of the nameplate (serial number).
- d) Contact the repair station to make sure it is available before dropping off the machine.

Go to the repair station with the complete machine packed, accompanied by the purchase invoice and the station support sheet downloadable after the service request is completed on the SWAP-Europe site

For machines with engine failure from manufacturers BRIGGS & STRATTON, HONDA and RATO, please refer to the following instructions.

Repairs will be done by approved engine manufacturers of these manufacturers, see their site:

- <http://www.briggsandstratton.com/eu/fr>
- <http://www.honda-engines-eu.com/fr/service-network-page;jsessionid=5EE8456CF39CD572AA2AEEDFD290CDAE>
- <https://www.rato-europe.com/it/service-network>

**Please keep your original packaging to allow for after-sales service returns or pack your machine with a similar cardboard box of the same dimensions.**

**For any question concerning our after-sales service you can make a request on our website <https://services.swap-europe.com>**

**Our hotline remains available at +33 (9) 70 75 30 30.**



### THE WARRANTY DOES NOT COVER:

- Start-up and setting up of the product.
- Damage resulting from normal wear and tear of the product.
- Damage resulting from improper use of the product.
- Damage resulting from assembly or start-up not in accordance with the user manual.
- Breakdowns related to carburetion beyond 90 days and fouling of carburetors.
- Periodic and standard maintenance events.
- Actions of modification and dismantling that directly void the warranty.
- Products whose original authentication marking (brand, serial number) has been degraded, altered or withdrawn.
- Replacement of consumables.
- The use of non-original parts.
- Breakage of parts following impacts or projections.
- Accessories breakdowns.
- Defects and their consequences linked to any external cause.
- Loss of components and loss due to insufficient screwing.
- Cutting components and any damage related to the loosening of parts.
- Overload or overheating.
- Poor power supply quality: faulty voltage, voltage error, etc.
- Damages resulting from the deprivation of enjoyment of the product during the time necessary for repairs and more generally the costs related to the immobilization of the product.
- The costs of a second opinion established by a third party following an estimate by a SWAP-Europe repair station
- The use of a product which would show a defect or a breakage which was not the subject of an immediate report and/or repair with the services of SWAP-Europe.
- Deterioration linked to transport and storage\*.
- Launchers beyond 90 days.
- Oil, petrol, grease.
- Damages related to the use of non-compliant fuels or lubricants.

\* In accordance with transport legislation, damage related to transport must be declared to carriers within 48 hours maximum after observation by registered letter with acknowledgement of receipt.

This document is a supplement to your notice, a non-exhaustive list.

**Attention:** all orders must be checked in the presence of the delivery person. In case of refusal by the delivery person, it you must simply refuse the delivery and notify your refusal.

**Reminder:** the reserves do not exclude the notification by registered letter with acknowledgement within 72 hours.

**Information:**

Thermal devices must be wintered each season (service available on the SWAP-Europe site). Batteries must be charged before being stored.