

IMPORTANT - À CONSERVER POUR
CONSULTATION ULTÉRIEURE
À LIRE ATTENTIVEMENT
IMPORTANTE - CONSERVAR PARA
CONSULTAS FUTURAS
LEER ATENTAMENTE

TONNELLE 3X3 FARRAGO

L. 300 x H. 227 x P. 300 CM,

Aluminium, acier

Aluminio, acero

NOTICE DE MONTAGE

INSTRUCCIONES DE MONTAJE



TEMPS DE MONTAGE : 120 minutes
TIEMPO DE MONTAJE: 120 minutos



OUTILLAGE : inclus
HERRAMIENTAS: incluido



NOMBRE DE PERSONNES : 4
NUMERO DE PERSONAS: 4



Service Relation Client
Servicio de atención al cliente:
83, Avenue de la Grande Armée
75782 Paris cedex 16 - FRANCE
T. (+33) 1 76 28 44 55 (Appel non surtaxé)
conso.jardin@teract.com



- FR**
- 1 - Aménagez-vous une zone de montage, une couverture protégera des rayures
 - 2 - Repérez les pièces constituant votre produit
 - 3 - Regroupez et comptez la quincaillerie
 - 4 - Munissez-vous de l'outillage nécessaire
 - 5 - Procédez au montage, ne jamais forcer sur les assemblages, resserrez les vis après quelques temps d'usage

- ES**
- 1 - Prepare una zona de montaje, una manta protegerá de rayaduras
 - 2 - Localice las piezas que componen su producto
 - 3 - Reagrupe y cuente la tornillería
 - 4 - Prepare las herramientas necesarias
 - 5 - Proceda al montaje, no forzar sobre los ensamblajes, apretar los tornillos después de algún tiempo de uso

TONNELLE 3X3 FARRAGO

REF.: 1612260

EAN: 3275974143443

SAISON: SS2026

1		8 x 8 x 226cm	x2
2		8 x 8 x 226cm	x2
3		10.2 x 7.35 x 279.2cm	x1
4		10.2 x 10 x 279.2cm	x1
5		10 x 3 x 277cm	x2
6		1.8 x 1.8 x 280.2cm	x1
7		14.36 x 3.78 x 283.5cm	x21
8		20.7 x 3 x 289cm	x1
9		11.9 x 3.35 x 289cm	x1
10		1.3 x 14 x 101cm	x1
11		8 x 8 x 10.42cm	x4
12		10 x 10 x 2.7cm	x8
13		13.5 x 13.5 x 3cm	x4
14		14.4 x 14.4 x 3.2cm	x4
15		9.1 x 6.2 x 2.95cm	x1

16		8.5 x 3.5 x 15.8cm	x1
17		9.1 x 6.2 x 2.33cm	x1
18		1.29 x 1.29 x 14cm	x1
19		1 x 1 x 2.8cm	x1
A		M8 x 15mm	x16
B		M6 x 15mm	x66
C		Ø16 x Ø8.5 x 1.5mm	x8
D		Ø14 x Ø6.5 x 1mm	x62
E		Ø16 x 5.5mm	x44
F		M8 x 80mm	x8
G		66 x 24 x 4.6mm	x1
H		95.5 x 28 x 3mm	x1
I		110 x 16 x 32mm	x1
K		M6 x 45mm	x2

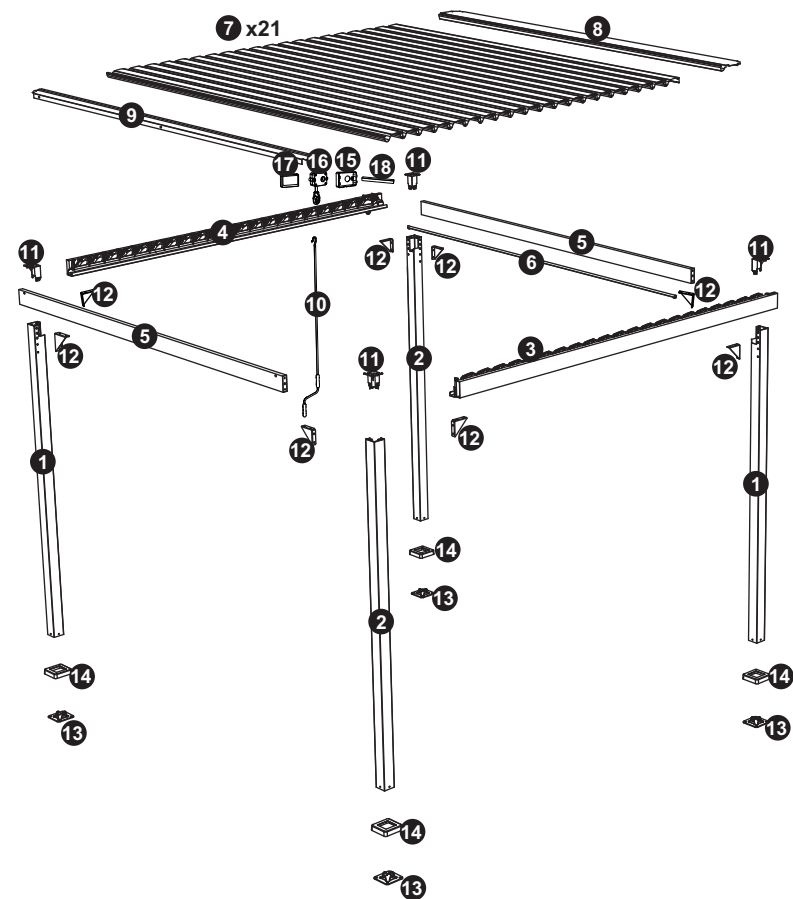

1

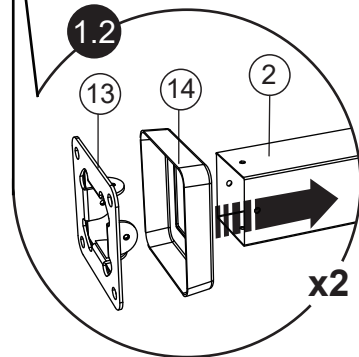
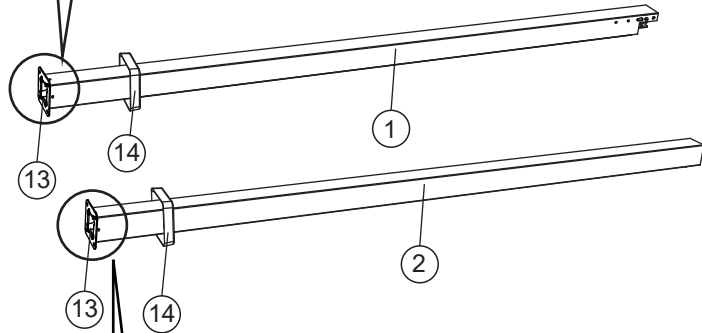
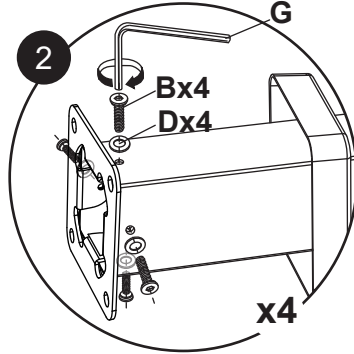
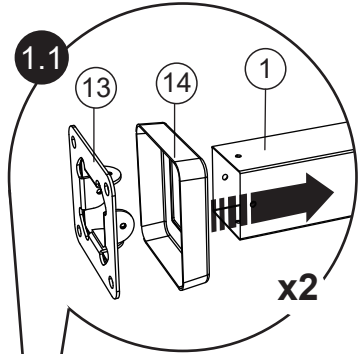

2

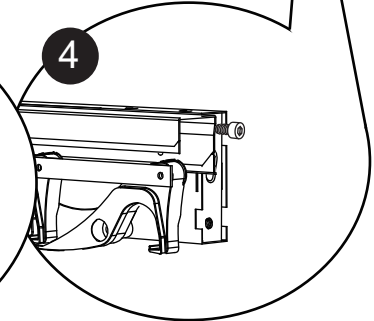
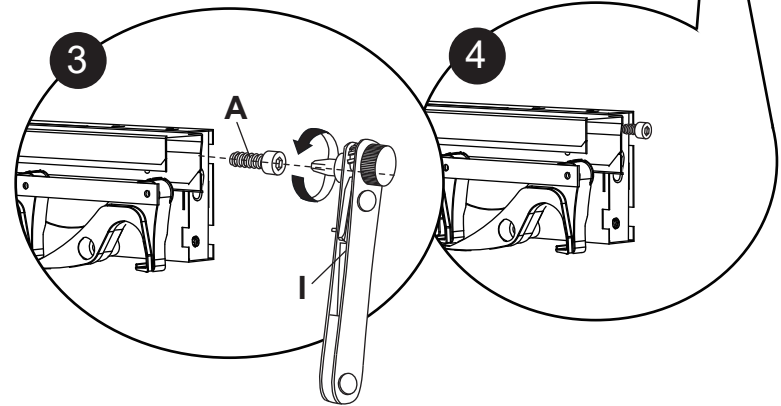
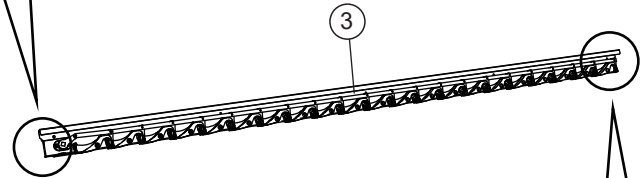
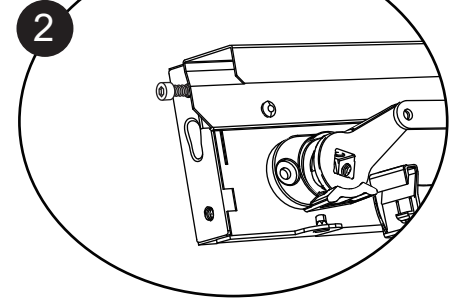
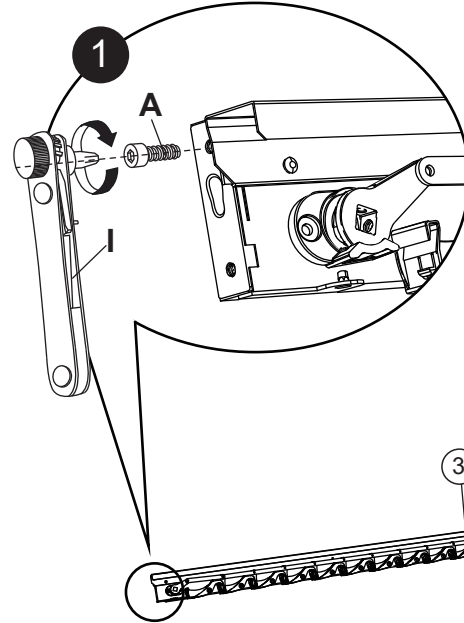
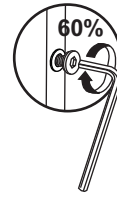

3

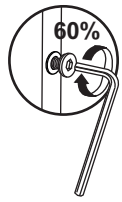

1

2

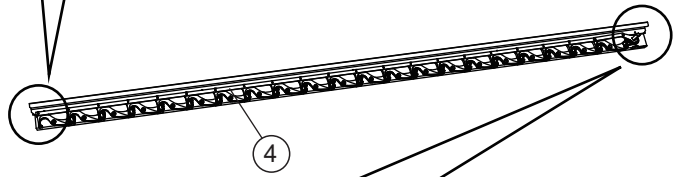
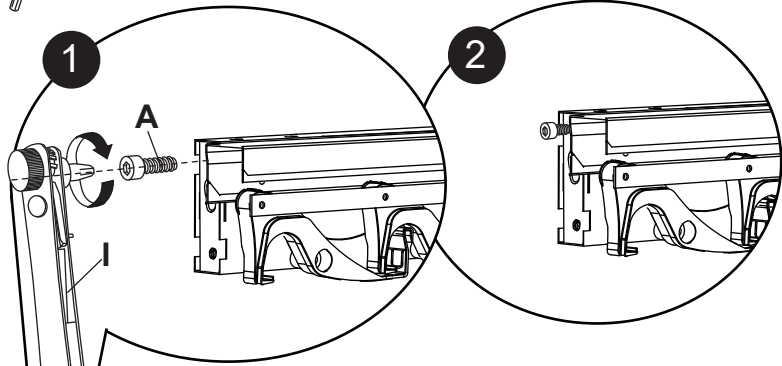

3

4

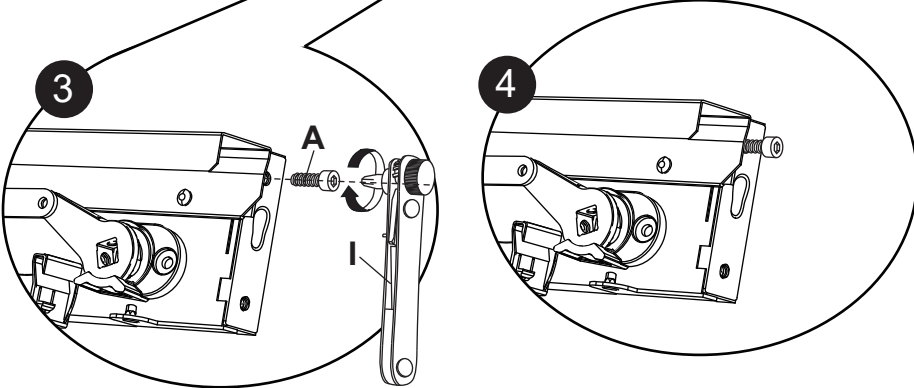

4

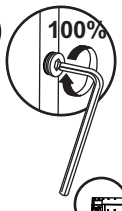

2

1

3

4

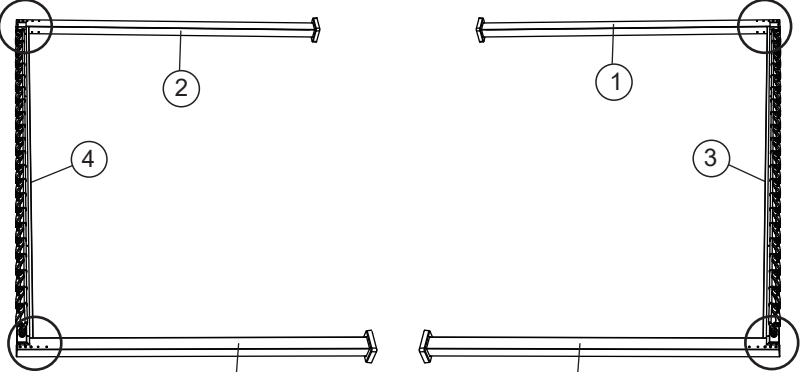

1

2

x4

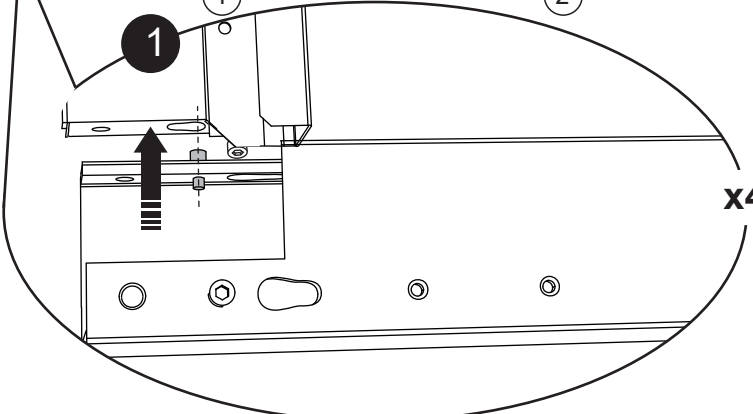

2

3

x4

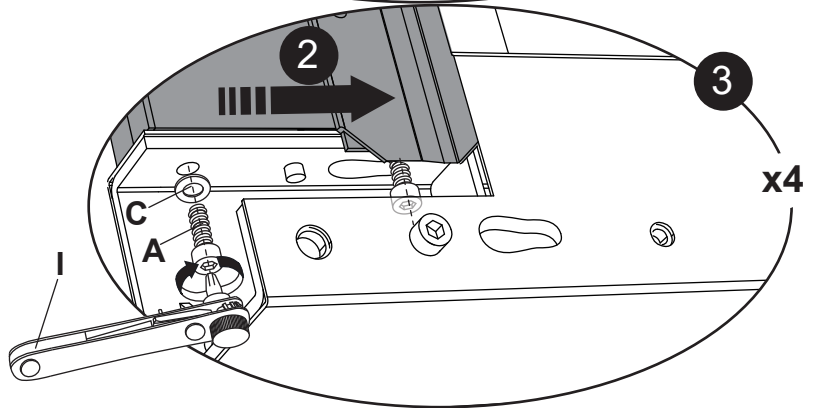

5

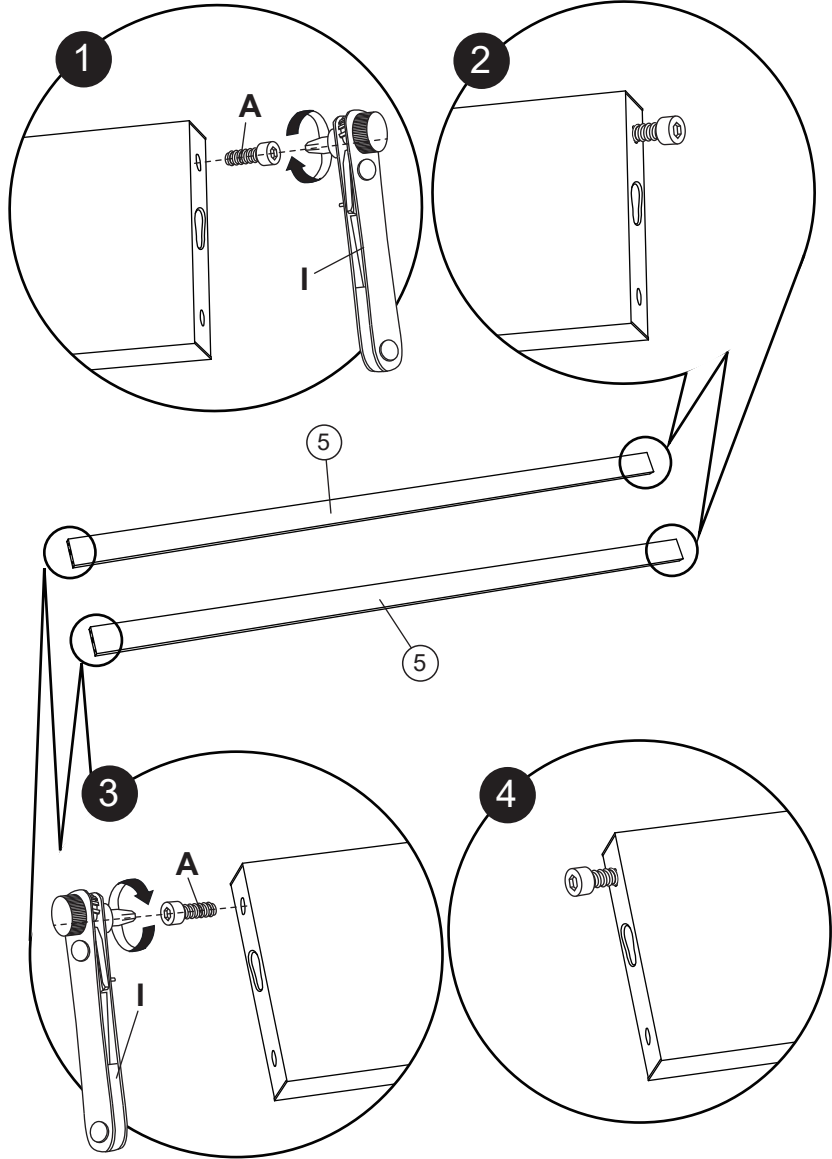
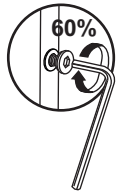

6

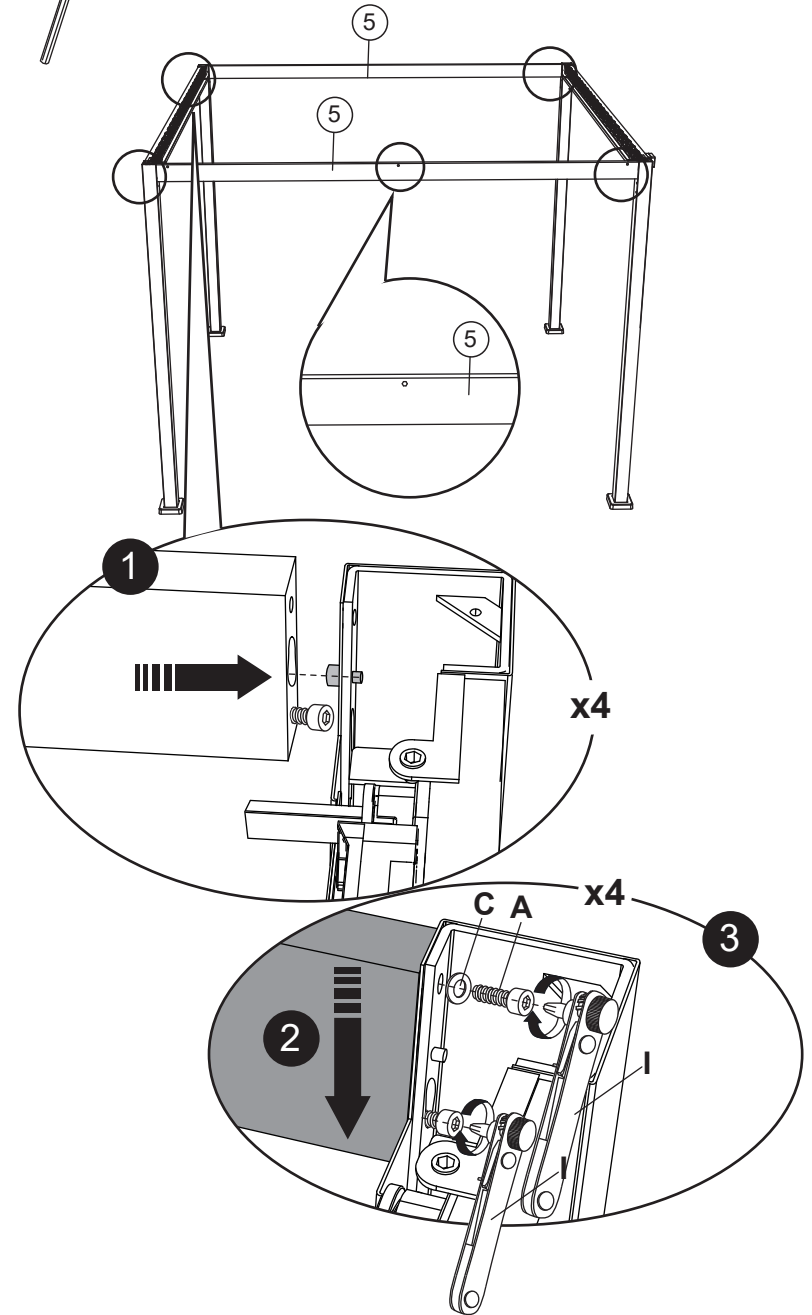
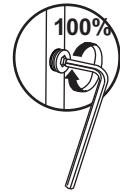

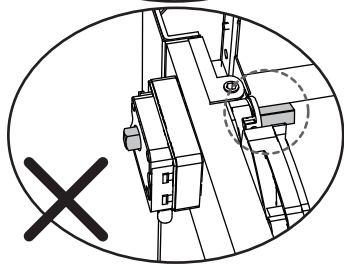
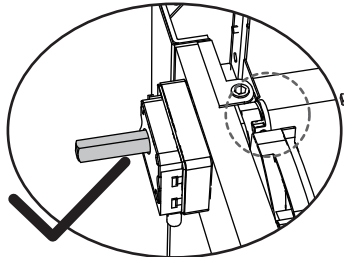
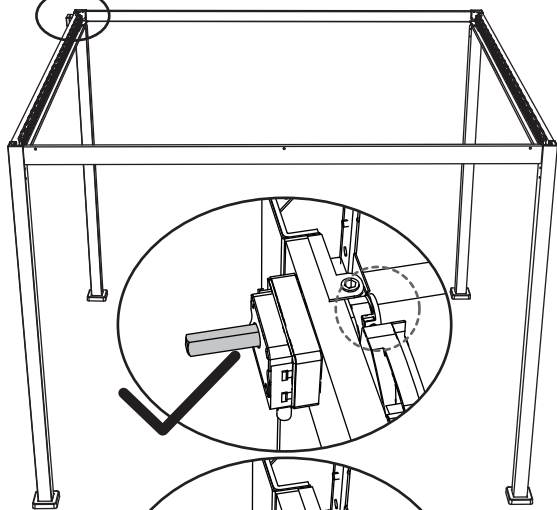
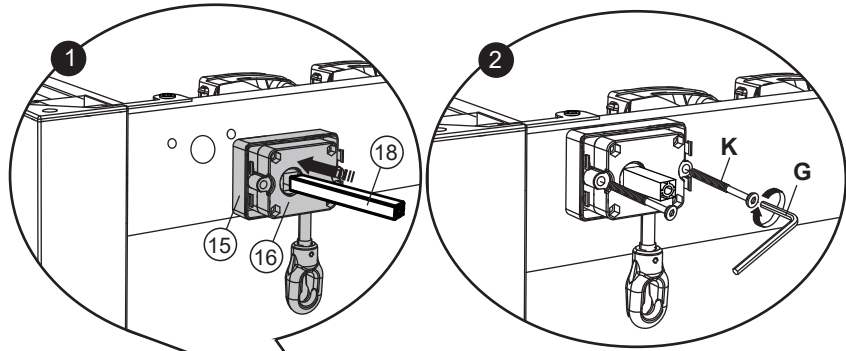
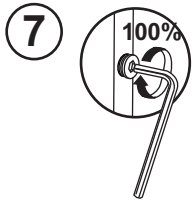

8

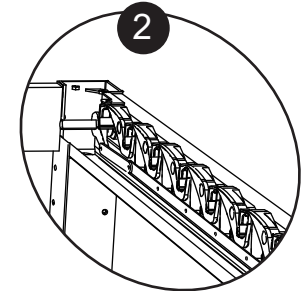
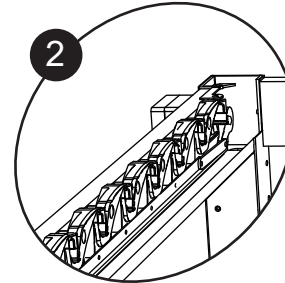
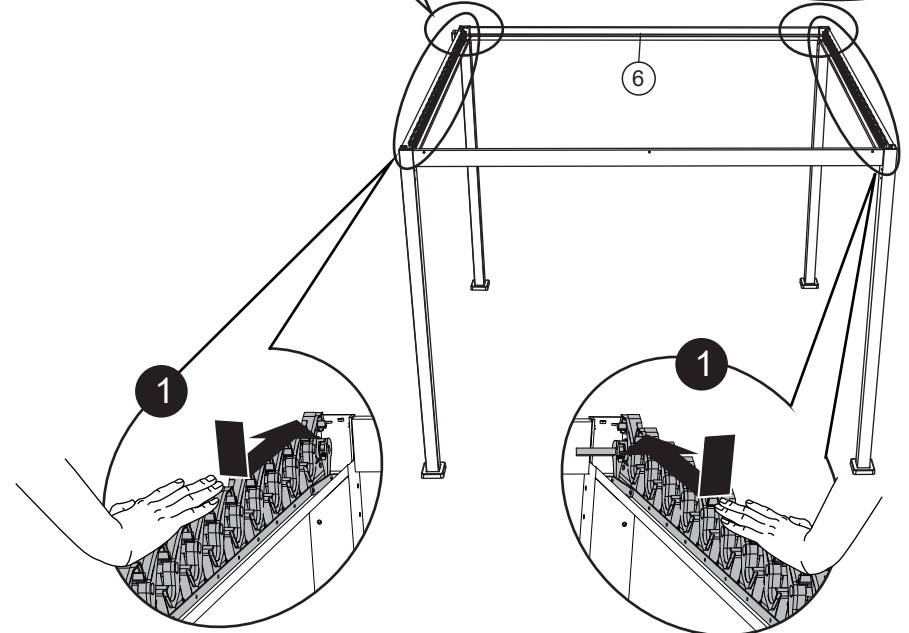
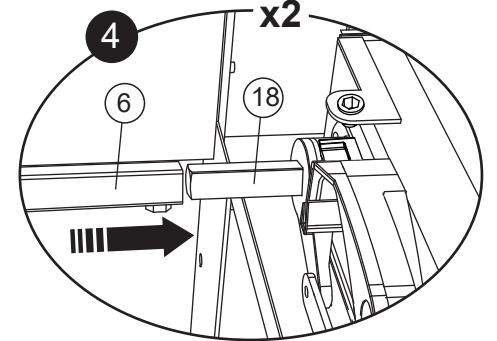
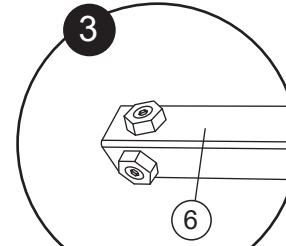

9

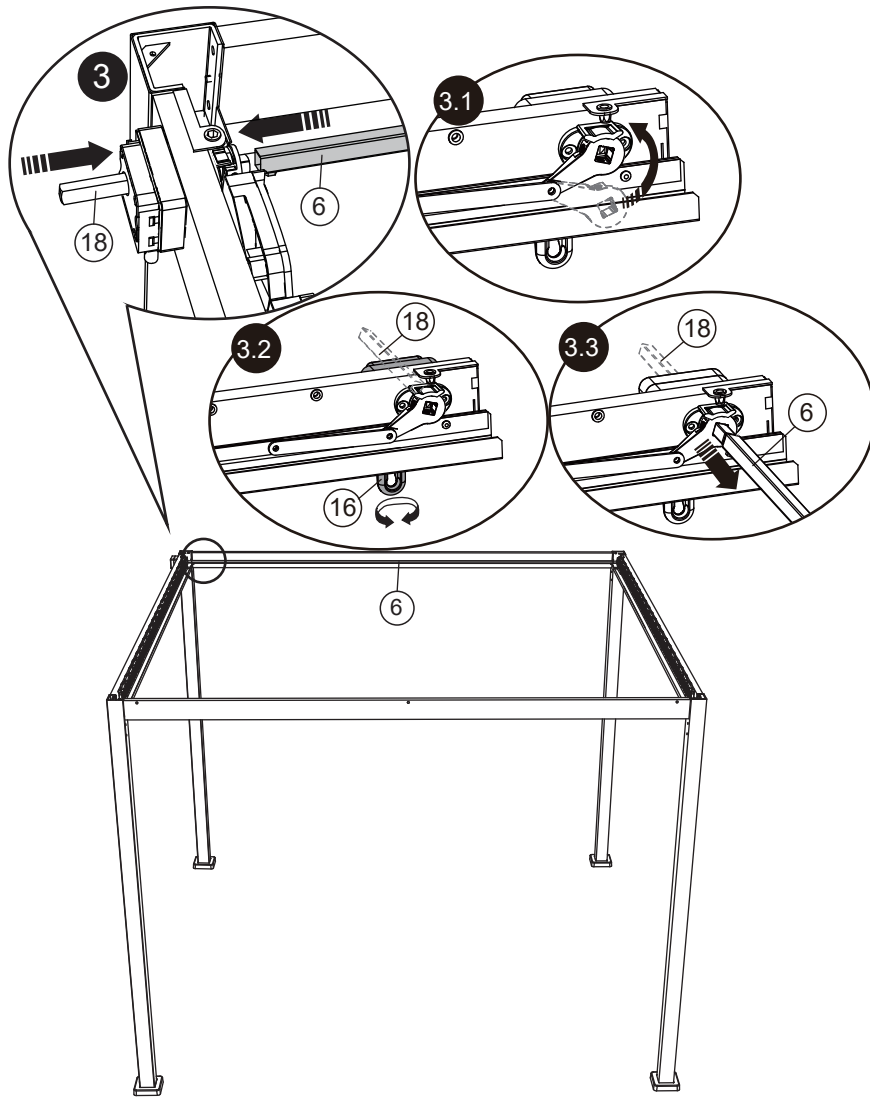

10

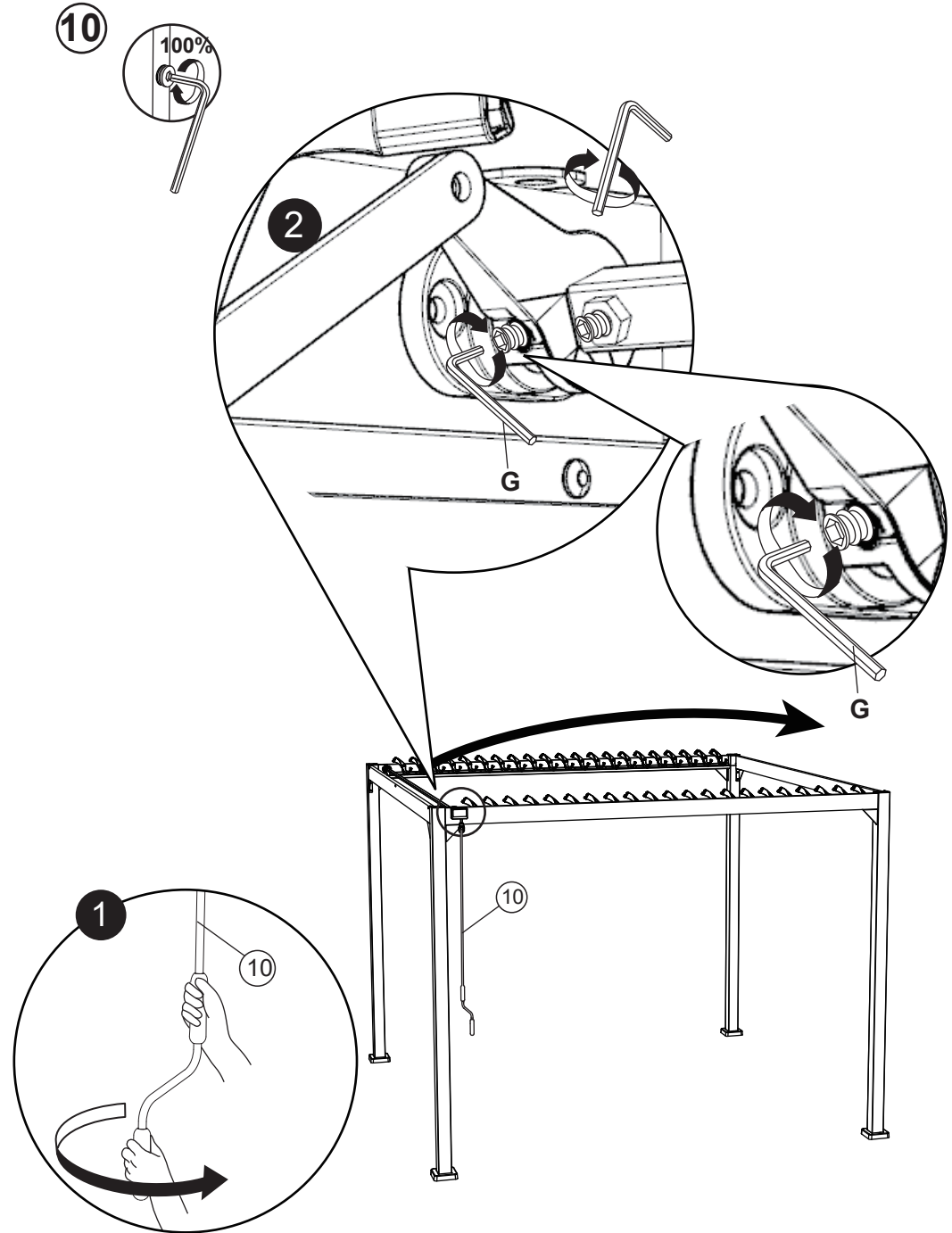

11

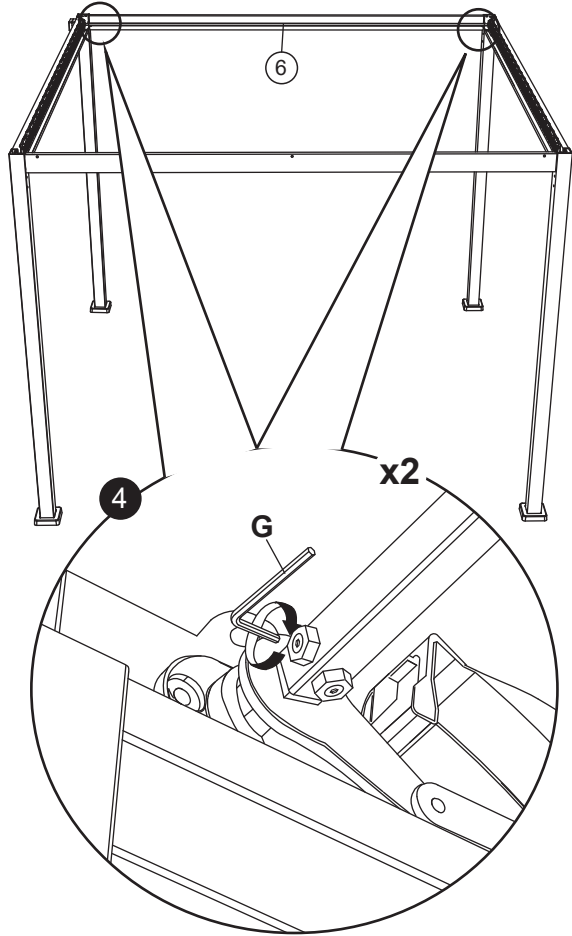
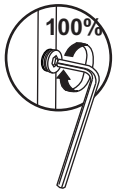

12

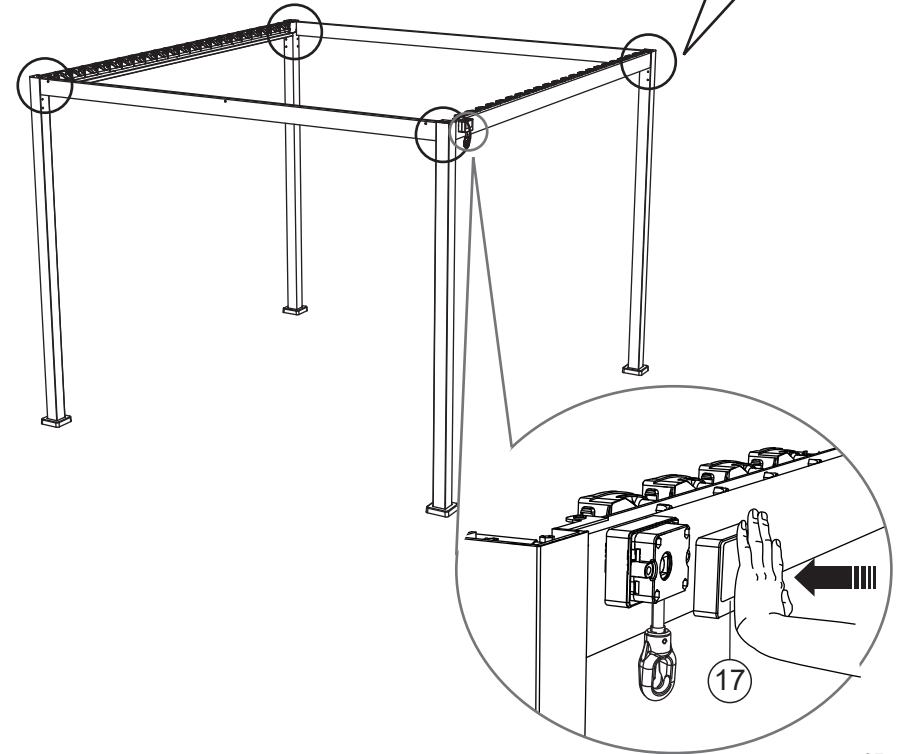
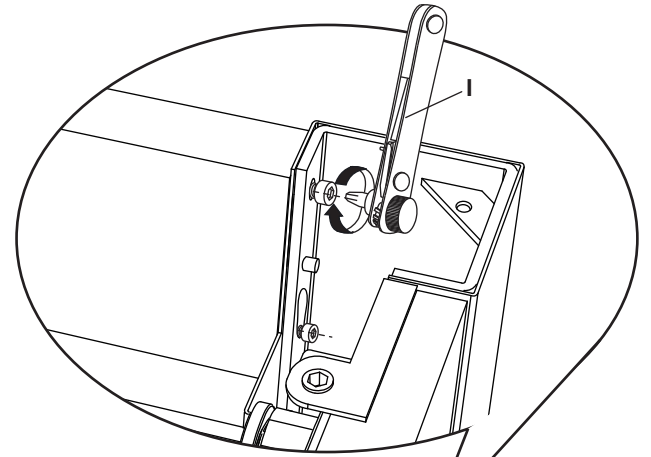
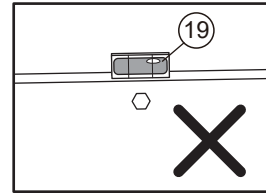
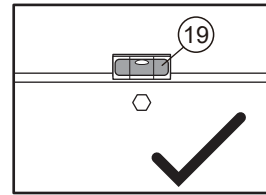
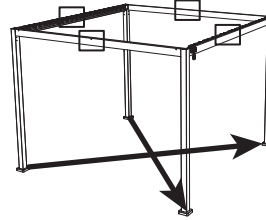

13

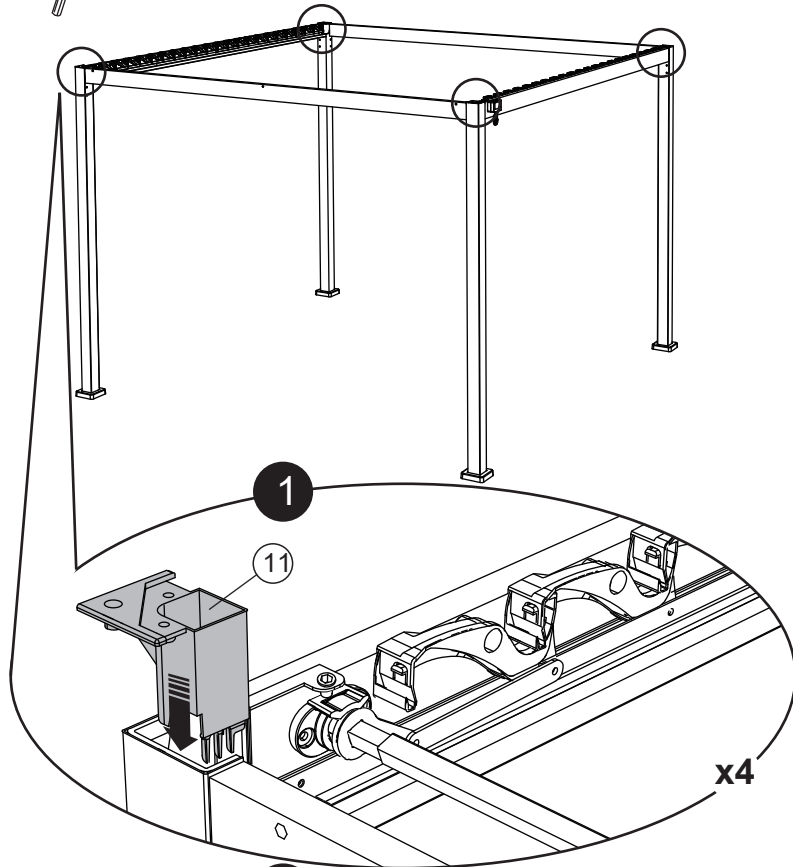
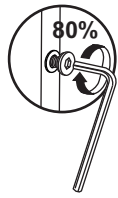

1

11

x4

2

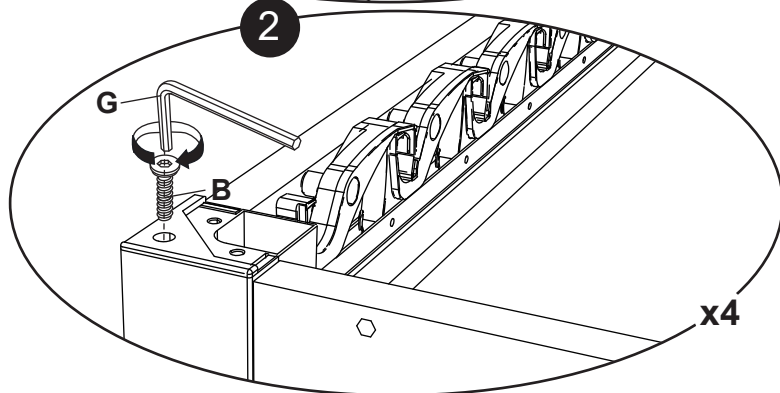

x4

14

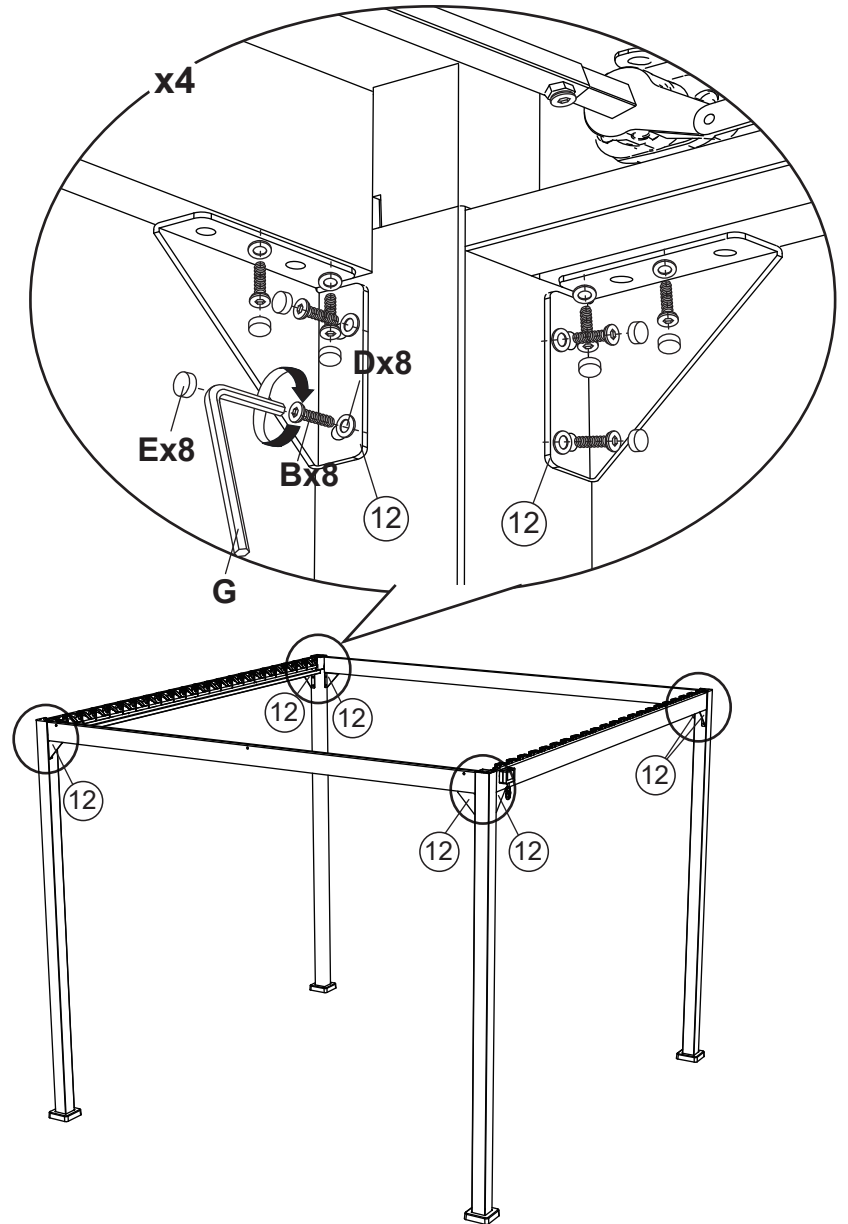

x4

12

12

12

12

12

12

12

12

15

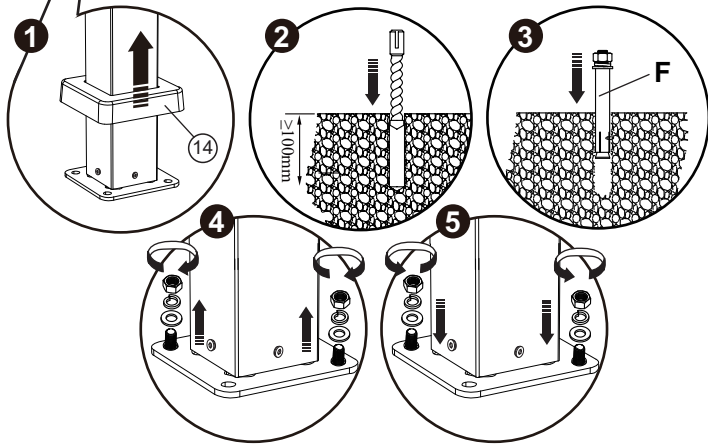
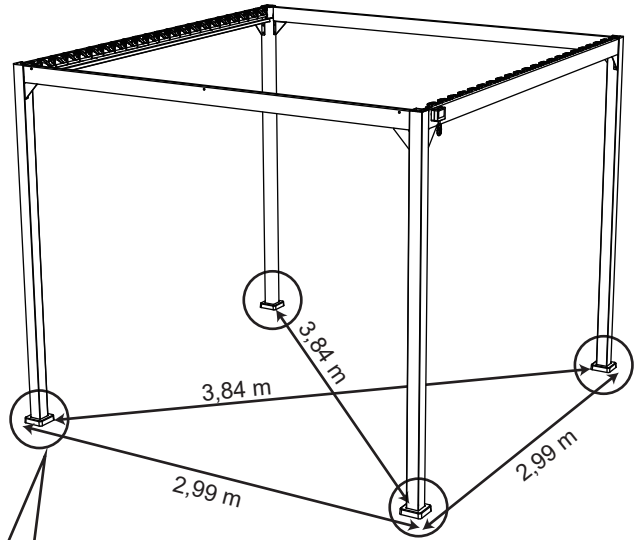
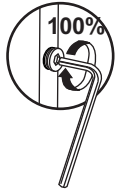

16

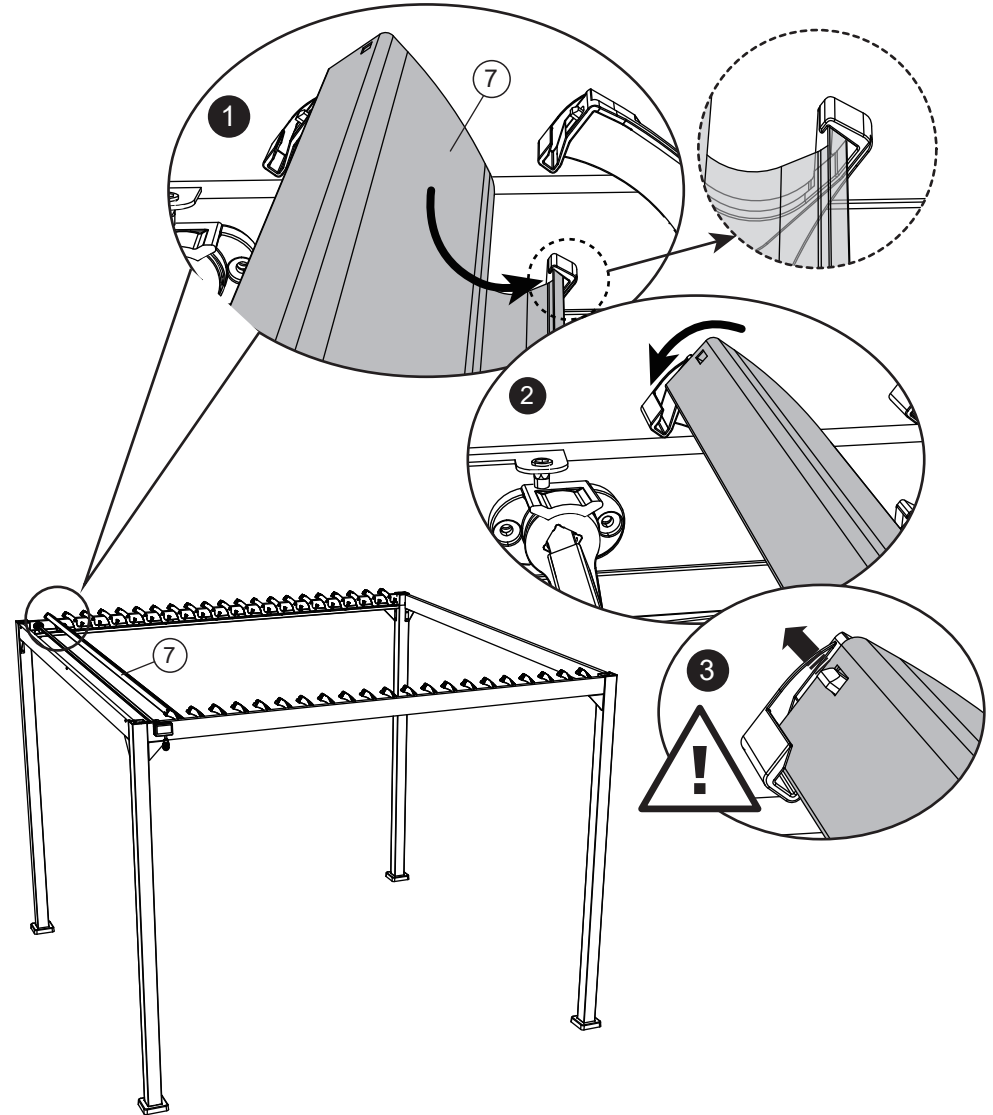
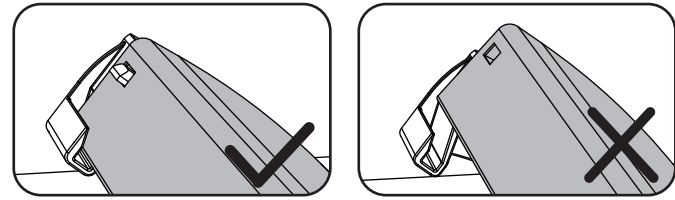

17

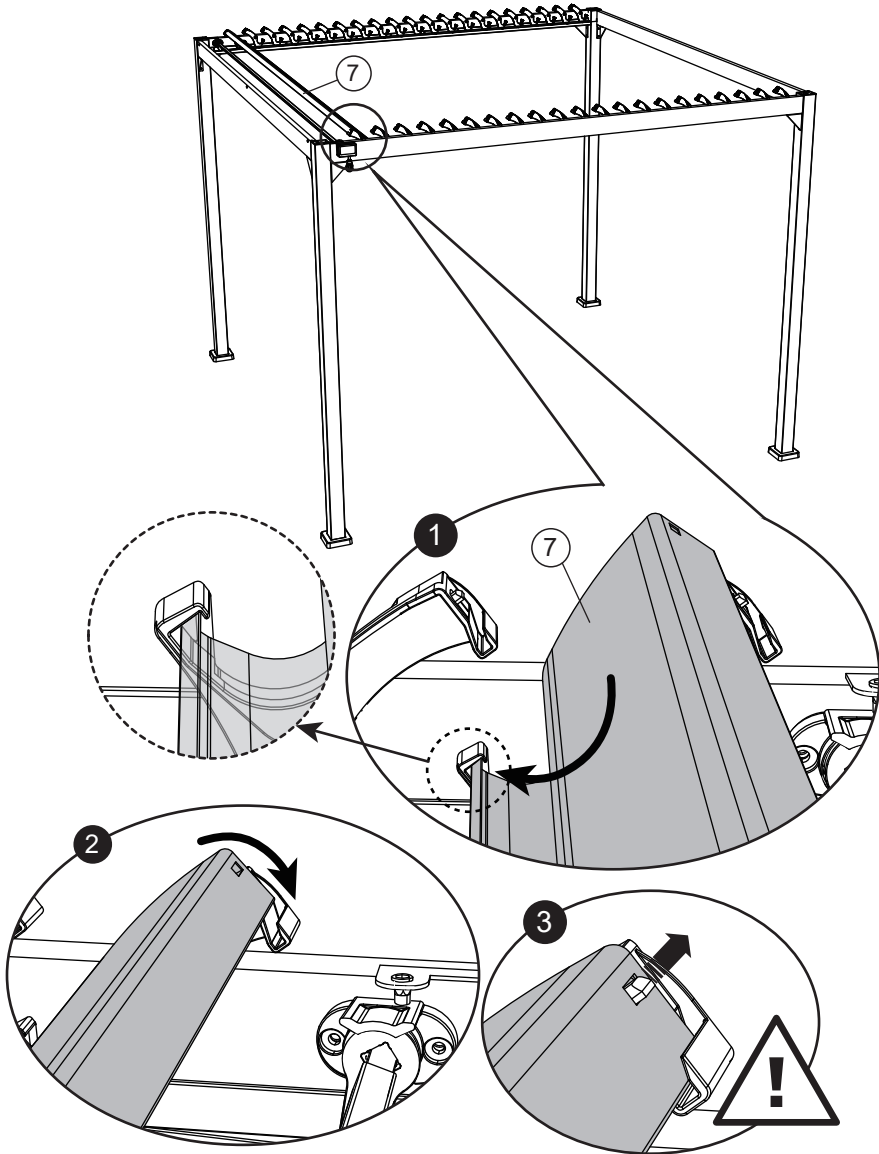
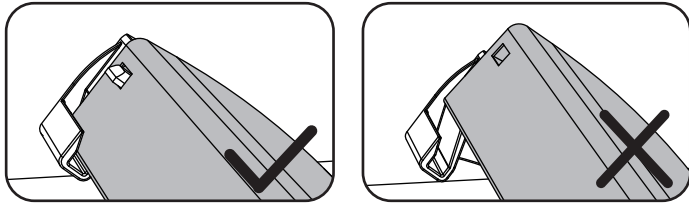

18

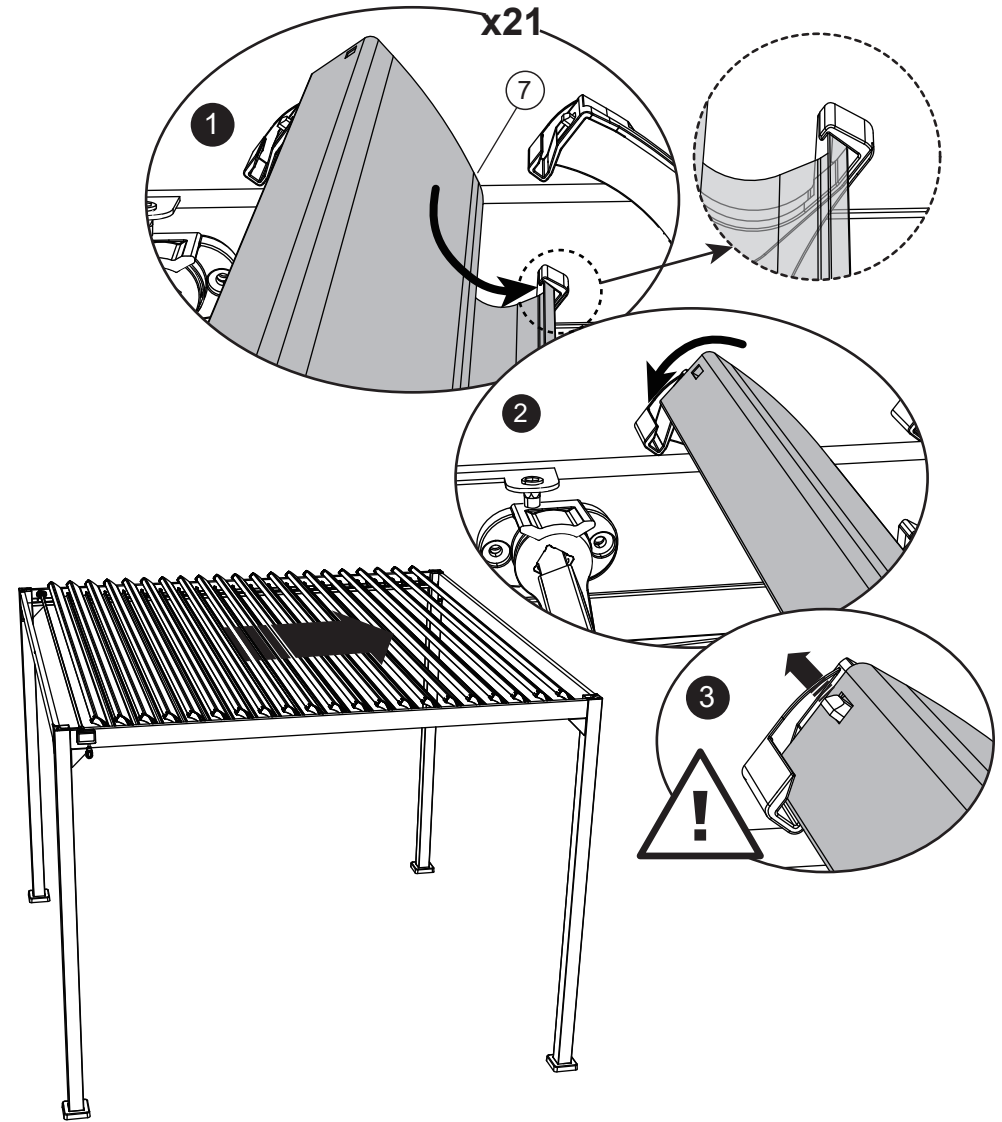

19

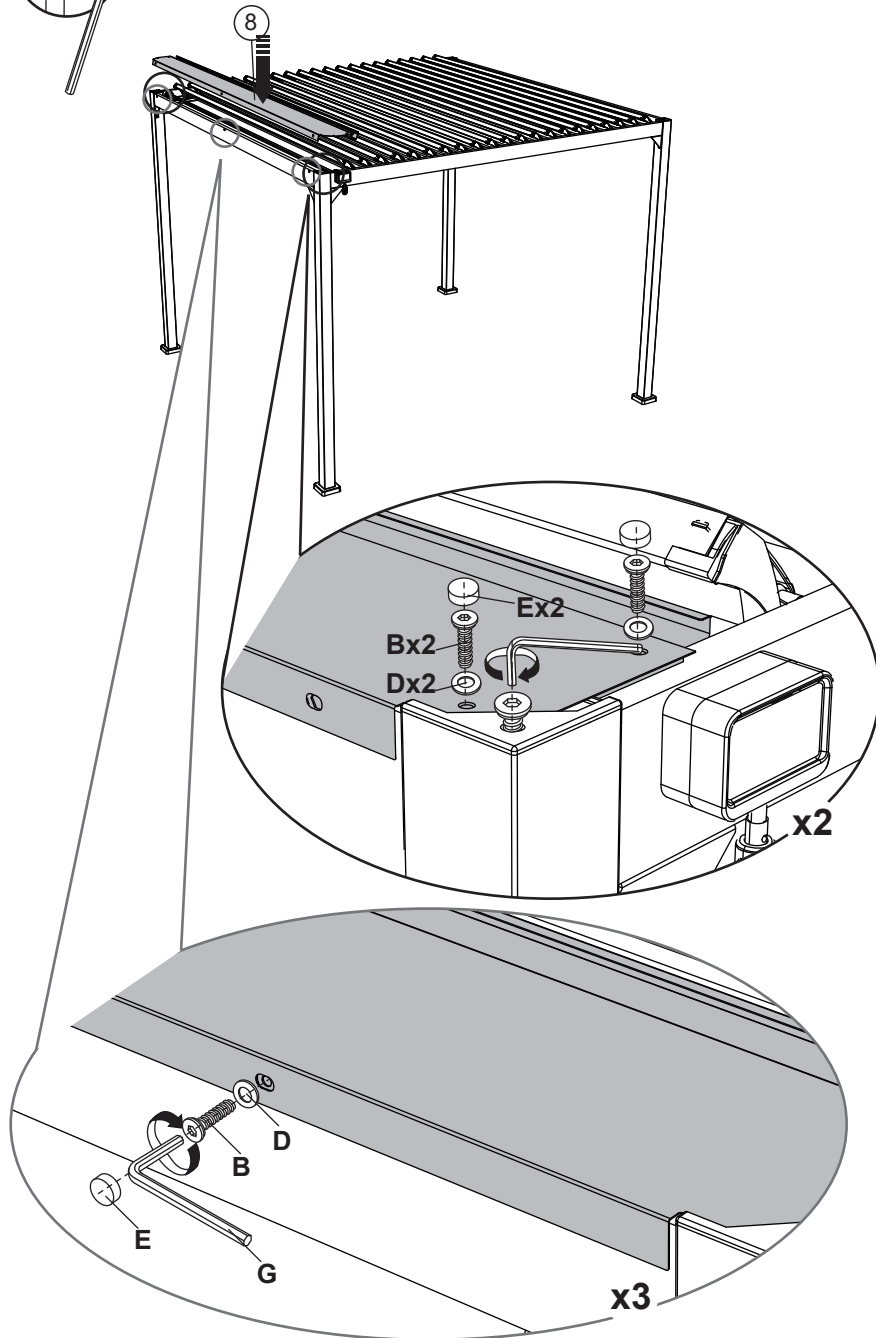
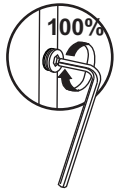

20

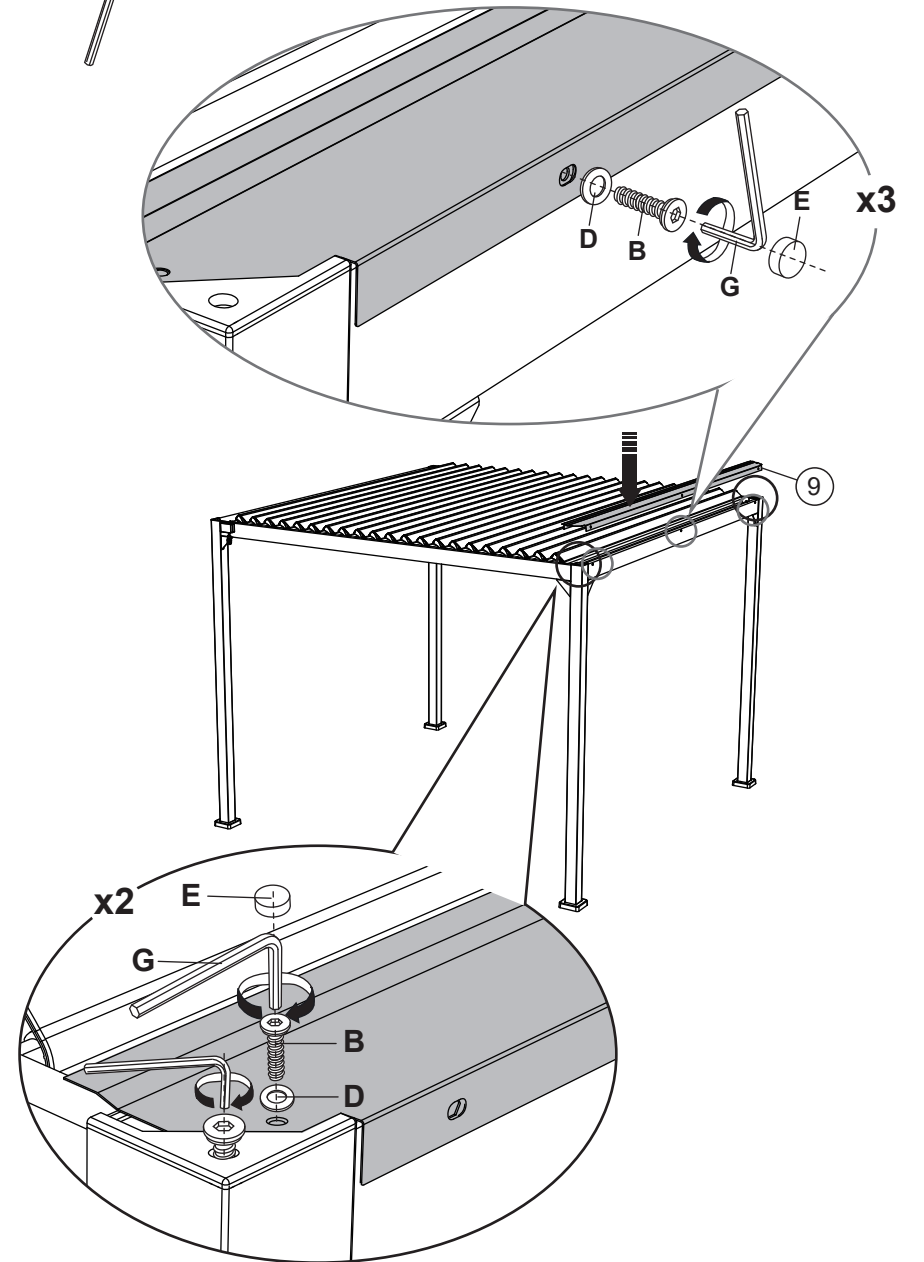

21

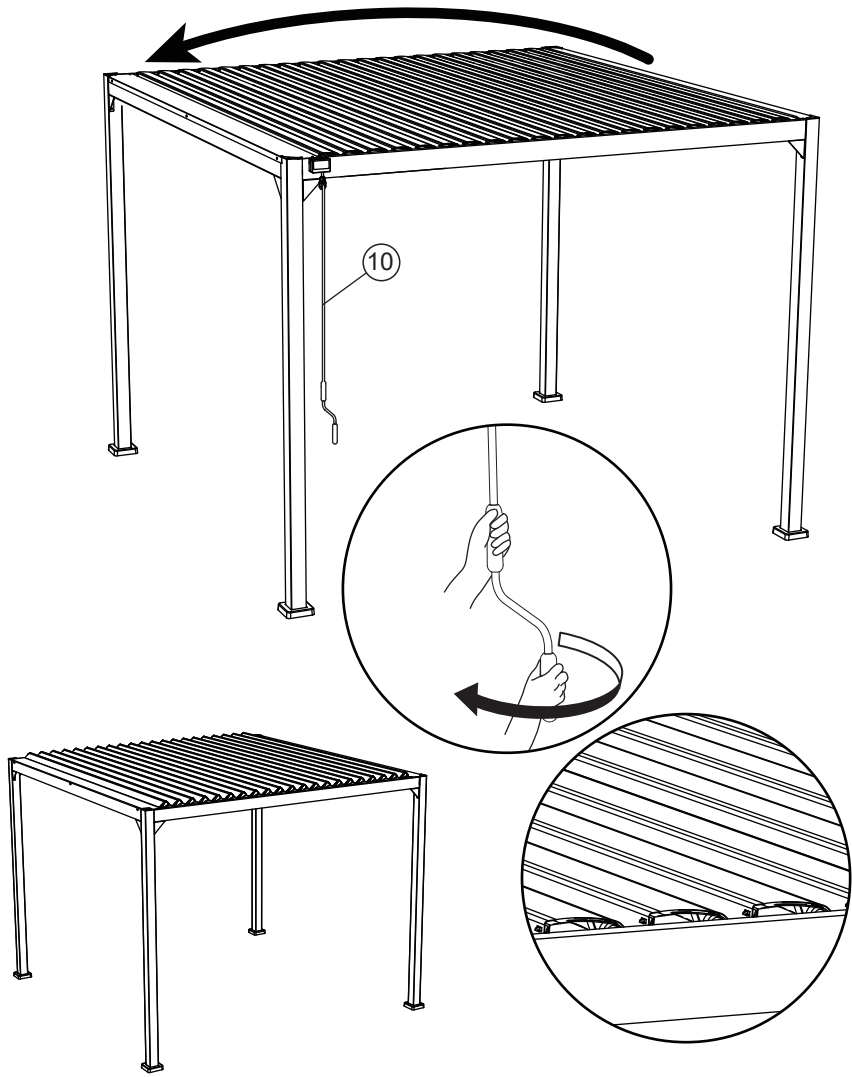

22

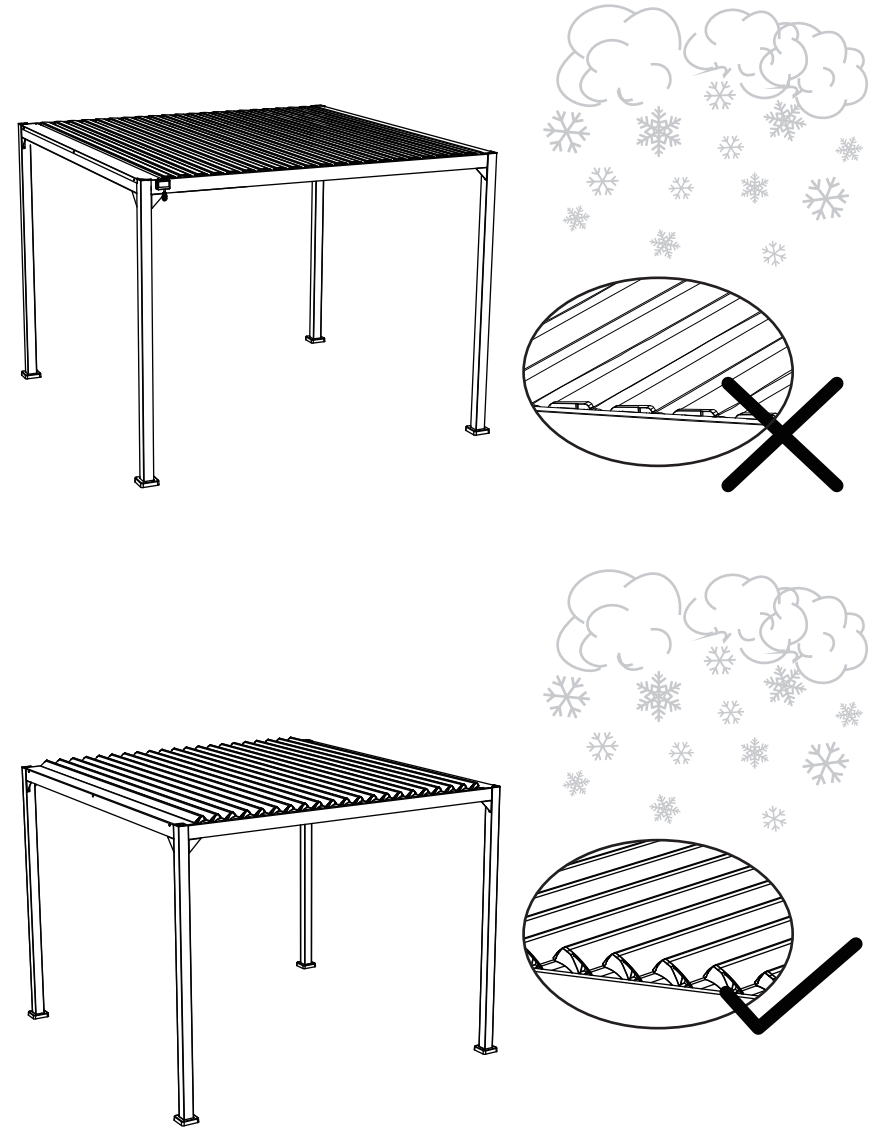

FR

Utilisation :

- Positionner de manière stable sur un sol plan.

Entretien :

- Ne pas laver car cela enlèverait le pouvoir déperlant de la toile.
- Nettoyer avec une éponge humide et savonneuse sans agent corrosif.
- Sécher avec un chiffon doux, propre et sec.
- Ne pas utiliser un nettoyeur haute pression.
- Ne pas utiliser de javel, d'acide, de solvant, ni de produit nettoyant abrasif.
- Vérifier le serrage des vis régulièrement.

Hivernage :

- Il est conseillé de rentrer le mobilier pendant l'hiver et les périodes d'inutilisation prolongées.
 - Avant de ranger le produit, veiller à ce qu'il soit propre et sec.
 - À ranger à l'intérieur ou dans une zone hors gel, sous une housse appropriée.
- Toutes ces précautions augmenteront la durée de vie de votre mobilier.*

USAGE DOMESTIQUE UNIQUEMENT

À MONTER SOI-MÊME

ES

Uso:

- Colocar de manera estable sobre un suelo plano.

Cuidado y mantenimiento:

- No lavar, dado que eliminaría las propiedades hidrófugas de la tela.
- Limpiar con una esponja humedecida con agua jabonosa sin agentes corrosivos.
- Secar con un paño suave, limpio y seco.
- No utilizar una hidrolimpiadora.
- No utilizar lejías, ácidos, disolventes ni otros productos de limpieza abrasivos.
- Comprobar los tornillos de sujeción periódicamente.

Invernada:

- Se aconseja guardar el mobiliario en un lugar resguardado durante el invierno o cuando no se vaya a utilizar por un largo periodo de tiempo.
 - Antes de guardar el producto, compruebe que esté limpio y seco.
 - A guardar en un lugar de interior o donde quede resguardado de las heladas, en un área alzada.
- Estas medidas de precaución prolongarán la vida útil de su mobiliario.*

USO DOMÉSTICO EXCLUSIVAMENTE

AUTO ENSAMBLAJE